



Dispan

CATÁLOGO DE PRODUTOS



Uma História de Sucesso

A History of Success

Há mais de 29 anos no mercado, nossa especialidade é desenvolver e fabricar infraestruturas metálicas do tipo eletrocalhas, perfilados, aramados e leitos tipo escada para passagem de cabos. Para cada linha de produto, oferecemos um conjunto completo de conexões e materiais de fixação.

Com sede na cidade de Nova Odessa, uma filial em São Paulo e vários representantes por todo território nacional, somos um dos maiores fornecedores do setor no Brasil.

Contamos com mais de 10.000m² de parque fabril, equipado com as mais modernas tecnologias, para atender todos os requisitos de qualidade do mercado. Nossos produtos são fabricados com matéria-prima adquirida nas principais usinas nacionais, que oferecem certificados de qualidade, garantindo alta resistência e comprovada qualidade do material.

With more than 25 years working, our specialty is develop and manufacture infrastructure for passing cables like cable trays, steel profiles, wire fitting and bed ladders. For each product line, we offer a complete set of connections and fixation materials.

With the headquarters in Nova Odessa, a branch in São Paulo and several representatives throughout the country, we are one of the largest supplier of this industry in Brazil.

We have more than ten thousand square meters of industrial park, equipped with the latest technologies for meeting all quality requirements of the market. The raw material of our products is gained at the main national mills, which offer quality certificates, ensuring the high strength and the quality of the material.



Responsabilidade Empresarial

Business Responsibility

Seguimos uma política de melhoria contínua, por meio da padronização de todos os nossos processos, estabelecendo normas, globalizando procedimentos e agregando valores aos nossos produtos. Focamos a satisfação de nossos clientes, através da instituição de um paralelo entre preço, qualidade e prazo.

Lançando mão de artefatos e ferramentas que auxiliam nossos clientes durante o desenvolvimento de projetos e gerando benefícios mútuos na relação cliente-fornecedor, nós fazemos a diferença. Experiência e dedicação formam um departamento comercial diferenciado, com atendimento personalizado, que permite conhecer todas as exigências de nossos clientes e supri-las com eficiência e segurança. Possuímos um departamento técnico com engenheiros e projetistas especializados, que atuam no desenvolvimento de novos produtos e oferecem todo suporte necessário, para garantir a utilização correta do produto e evitar riscos durante o processo de instalação. Nossa principal conduta é industrializar produtos de alto padrão, que vão de encontro às necessidades de nossos clientes.

We follow a policy of continuous improvement through standardization of all our processes, establishing norms, globalizing processes and adding value to our products. We focus on the satisfaction of our customers by establishing a line between price, quality and deadline.

Using artifacts and tools that help our customers during the development of projects and creating mutual benefits in the customer-supplier relationship, we make the difference. Experience and dedication make a differentiated commercial department, with personalized care, that allows us knowing all the demands of our customers and supply them with efficiency and safety. We have a technical department with expert engineers and designers working on developing new products, and providing all necessary support to assure the correct use of the product, so they can avoid risks during the installation process.

Our main management is industrialize high standard products, which meet the needs of our customers.

Áreas de Atuação

Practice Areas

Petróleo e Gás • Siderúrgica • Alimentícia
Açúcar e Álcool • Papel e Celulose • Mineração
Farmacêutica • Comercial • Off Shore

Oil and Gas • Steelmaker • Food Industry
Sugar and Alcohol • Paper and Pulp • Mining
Pharmaceuticals • Commercial • Off Shore



Plugins

Plugins

Além de ser referência na fabricação e distribuição de eletrocalhas, perfilados, leitos e aramados, a Dispan oferece o DPCAD: Um plug-in que consiste numa ampla biblioteca 3D desses produtos, facilitando a concepção da área elétrica em seus projetos. Acesse o site da Dispan, assista as videoaulas e faça o download do programa, gratuitamente: www.dispan.com.br

Besides being a reference in manufacturing and distributing cable trays, steel profiles, wire fitting and bed ladders, Dispan offers the DPCAD: a plug-in that consists on a large library of these products in 3D, making it easier to conception of the electric field in their projects. Visit the Dispan website, watch the video classes and download the program free: www.dispan.com.br



Patenteado



Qualidade Reconhecida

Recognized Quality



Prêmio Qualidade
Quality Award



Certificação
ISO 9001 : 2015
ISO 9001 : 2015 Certification

Catálogo Navieças

Catálogo Navieças
Navieças Catalog



Certificado ONIP
ONIP Certificate

Política de Qualidade

QUALITY POLICY

A Dispan tem como política de qualidade produzir e comercializar eletrocalhas, perfilados, leitos para cabos, eletrocalhas amarradas, acessórios e conexões para toda linha. Buscando sempre atender com eficácia os requisitos das partes interessadas, visando a melhoria contínua dos processos, lucratividade e satisfação dos clientes.

A Dispan estabeleceu sua Política de Qualidade, para garantir a adequação à organização e seu contexto, e às necessidades dos clientes, com o compromisso permanente com a melhoria contínua do sistema de gestão da qualidade e com o atendimento aos requisitos.

Desde de Outubro de 2010 a Dispan está certificada em conformidade com a Norma ABNT NBR ISO 9001:2008, e atualizado a partir de abril de 2019 com a nova versão ABNT NBR ISO 9001:2015.

Falta colocar o texto em inglês.

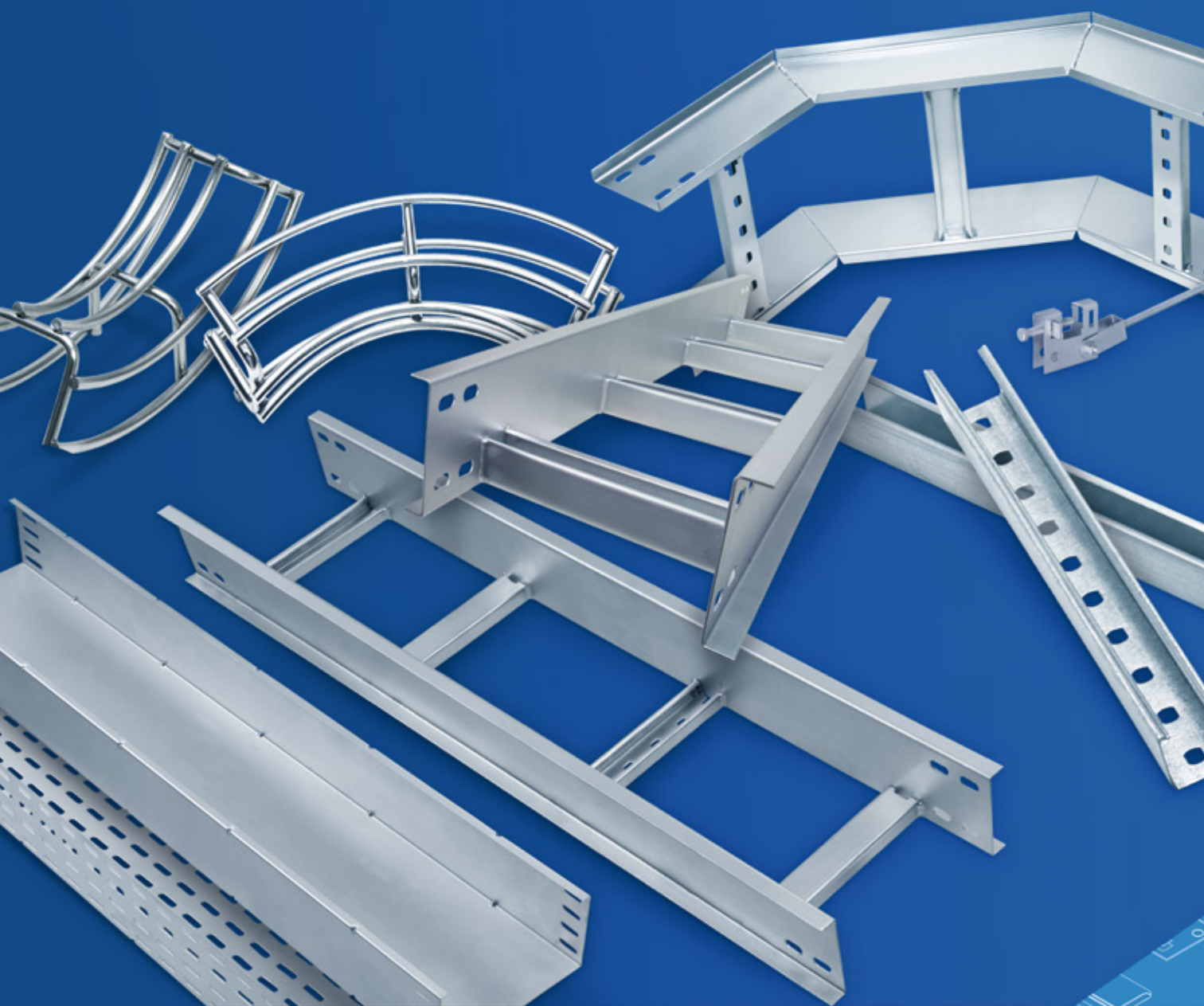

Matérias-primas básicas para produção

Basic raw materials for production

A Dispan trabalha com diversos tipos de materiais para o melhor atendimento das necessidades dos nossos clientes e parceiros. Dentre os materiais mais solicitados, estão:

Dispan works with several types of materials to improve our services to customers and partners. Among the most requested materials, there are:

AÇO CARBONO – 1008 E 1010 (AC)

CARBON STEEL – 1008 AND 1010 (AC)

O aço carbono 1008 e 1010 são os materiais mais utilizados, pois os mesmos, podem receber diversos tipos de acabamentos para melhoria da estética, bem como maior resistência aos intempéries, tais como acabamento por galvanização à fogo à base de zinco por imersão (GF), galvanização contínua à base de zinco, ou pré-zincagem (PZ), galvanização contínua a base de 50% de zinco e 50% de alumínio (galvalume), galvanização eletrolítica à base de zinco por eletrólise e pintura epóxi ou eletrostática a pó.

The carbon steel 1008 and 1010 are the most used materials because they can receive several types of finishes, for the improvement of esthetics as well as the improvement of resistance to weathering, such as hot-dip galvanizing with zinc, pre-galvanizing, galvanizing with 50% zinc and 50% aluminum, electrolytic galvanizing with zinc by electrolysis and epox painting or electrostatic powder.

AÇO INOX– 304, 316, 316L E 316I (AI)

STAINLESS STEEL – 304, 316, 316L AND 316I (AI)

Material muito utilizado em segmentos onde a limpeza seja contínua ou a agressividade do ambiente seja elevada.

Por se tratar de um material mais nobre, o aço inox tem sido muito utilizado em indústrias alimentícias, estações de tratamento de águas e esgoto, refinarias de combustíveis e em alguns setores mais agressivos em usinas sucroalcooleiras e papelarias.

This material is widely used in sections where the cleaning is continuous, or the aggressiveness of the environment is high. Because it is a nobler material, stainless steel has been often used in food industries, in water treatment and sewage plants, in fuel refineries, in some sectors more aggressive in sugarcane mills and paper mills.

ALUMÍNIO (AL)

ALUMINUM (AL)

O alumínio também é um material nobre e com a vantagem de um ótimo acabamento pode criar estruturas extremamente rígidas com um peso bem menor em relação aos outros materiais ferrosos.

Este material tem sido muito utilizado em áreas onde o peso elevado pode trazer problemas de sobrecarga em suas estruturas.

Aluminum is also a noble material and with the advantage of have an excellent finish, and it can create extremely rigid structures with a lower weight compared to other ferrous materials.

This material has been widely used in areas where weight can bring overload problems in the structure.

Acabamento para o Aço Carbono

Finishing for Carbon Steel

Existem diversos tipos de acabamentos para fins estéticos ou de proteção do aço carbono 1008/1010. Em nosso ramo de atividade os acabamentos mais utilizados são:

- GALVANIZADO À FOGO (GF) • PRÉ-ZINCADO (PZ)
- GALVANIZADO ELETROLÍTICO (GE) • PINTURA ELETROSTÁTICA (PT)

There are several types of finishes for aesthetic purposes or protection of carbon steel 1008/1010. In our field of activity, the most used finishes are:

- *Hot dip galvanized (GF) • Pre-zincated (PZ)*
- *Electrolytic galvanized (GE) • Electrostatic painting (PT)*

GALVANIZADO À FOGO (GF) NBR-6323

HOT DIP GALVANIZED (GF) NBR-6323

A galvanização à fogo é um processo de aplicação de um revestimento de zinco em estruturas de aço ou ferro fundido, através da imersão destes materiais em um banho de zinco fundido. A simplicidade do processo e os baixos custos ao longo do tempo, trazem a galvanização à fogo por imersão uma vantagem sobre os outros métodos de proteção contra corrosão.

O processo de galvanização à fogo compreende a imersão das estruturas metálicas em um banho de zinco fundido a uma temperatura de aproximadamente 450°C, isso somente após uma adequada limpeza e preparação das peças a serem protegidas pelo banho de zinco. O rápido ataque da superfície da estrutura pelo zinco fundido produz uma camada composta por diferentes ligas zinco/ferro, que desenvolvem uma ligação muito forte com a superfície. Esta união é chamada de interação metalúrgica. Após a remoção da estrutura do banho, uma camada de zinco puro passa a recobrir a superfície da peça, produzindo uma coloração brilhante, acinzentada ou prateada, bastante característica do processo de galvanização à fogo por imersão.

A camada Zn-Fe possui uma dureza semelhante a do aço, fornecendo uma barreira protetora (proteção catódica), protegendo a estrutura da corrosão. Em adição, as camadas formadas pelo zinco protegem a estrutura da abrasão e impactos acidentais durante o período de uso.

A galvanização à fogo por imersão tem seu processo perfeitamente definido, sendo basicamente o mesmo para qualquer produto, podendo variar na espessura da camada de zinco depositada dependendo da geometria da peça, composição química e espessura do material base, no caso o aço carbono 1008/1010.

Neste processo de galvanização à fogo por imersão, as peças recebem uma camada de aproximadamente 49 à 60 micras de zinco, conforme a NBR-6323.

INDICAÇÃO DE USO - Este tipo de acabamento e proteção é mais indicado para:

- Uso externo com situação de intempérie.
- Locais com produtos químicos leves.
- Indústrias pesadas, do tipo: mineradoras, papel e celulose, óleo e gás, sucroalcooleiras, fundições etc.
- Em áreas costeiras, com salinidade moderada.

Hot dip galvanized is a process for applying a zinc coating on steel structures or cast iron, through the immersion of these materials in a bath of molten zinc. The simplicity of this process and the lower costs over time are advantages over other methods of protection against corrosion. This process comprises immersing the metal structures in a bath of molten zinc at a temperature of approximately 450°C, but only after proper cleaning and preparation of the parts to be protected by the zinc bath. The fast attack of the structure surface by the molten zinc produce a layer composed of different zinc/iron alloy, which develop a very strong bond with the surface. This union is called metallurgical interaction. After removing the structure from the bath of molten zinc, a layer of pure zinc becomes cover the surface of the piece, producing a shiny, grayish or silvery, quite characteristic of the process of hot dip galvanized by immersion.

The Zn-Fe layer has a hardness similar to steel, providing a protective barrier (cathodic protection), protecting the structure from corrosion. In addition, the zinc layers protect the structure from abrasion and accidental impacts during the use.

Hot dip galvanized by immersion has its process clearly defined, being almost the same for any product. This can vary in thickness of the zinc layer deposited depending on geometry of the piece, chemical composition and thickness of the base material, in this case, the carbon steel 1008/1010.

In this process of hot dip galvanized by immersion, the pieces receive a layer of approximately 49 microns of zinc, according to NBR-6323.

INDICATION OF USE - This type of finishing and protection is best suited for the conditions listed below:

- *Outdoor use with weatherproof situation.*
- *Places with mild chemicals.*
- *Heavy industries, such as mining, paper and cellulose, oil and gas, sugarcane, foundries, etc.*
- *In coastal areas with moderate salinity.*

Acabamento para o Aço Carbono

Finishing for Carbon Steel

PRÉ-ZINCADO (PZ) NBR-7008/7013

PRE-ZINCED (PZ) – NBR 7008/7013

Hoje, o processo de revestimento contínuo por imersão à quente para chapas de aço é amplamente utilizado e empregado em todo o mundo. Foi originalmente desenvolvido há mais de cinquenta anos para galvanização com revestimentos de zinco.

Este processo se tornou uma operação avançada tecnicamente e muito sofisticada, e se tornou possível, graças à disponibilidade de sistemas de controles computadorizados mecânicos/elétricos.

O revestimento contínuo por imersão à quente, mais conhecido como pré-zincagem, tem como princípio básico a aplicação de um revestimento fundido à base de zinco na superfície de uma chapa de aço, por um processo contínuo, ou seja, a chapa de aço é passada continuamente por uma banho de metal fundido (neste caso o zinco) à uma velocidade de 600 pés por minuto. No banho de zinco fundido, a chapa de aço reage com o metal fundido, transformando-a em uma superfície mais resistente e com melhor acabamento.

Neste processo de imersão contínua, as chapas de aço recebem uma camada de aproximadamente 06 a 18 microns de zinco.

INDICAÇÃO DE USO - Este tipo de acabamento e proteção é mais indicado para:

- Uso interno com baixa umidade, de preferência em locais secos (locais confinados em forros).
- Áreas cobertas, do tipo shopping centers, centros de distribuições, supermercados, atacadistas, hospitais etc.

Nowadays, the continuous process of hot dip coating for sheet steel or pre-zincated are widely used around the world. The development of this process occurred originally more than 50 years ago for galvanization with zinc coatings.

This process became a technically advanced operation and very sophisticated. It became possible because of the availability of mechanical/electrical computerized controls systems.

The basic principle, as its name implies, involves applying a molten coating zinc based on the surface of a steel sheet by a continuous process. The sheet steel is continuously passed through a bath of molten metal, in this case zinc, at a speed of 600 feet per minute. In the molten zinc bath, the steel sheet reacts with the molten metal to connect the coating to the steel strip or sheet, turning it into a stronger surface and with better finish.

In this continuous immersion process, the steel sheets receive a layer of approximately 15 to 30 microns of zinc.

INDICATION OF USE - This type of finishing and protection is best suited for the conditions listed below:

- Internal use with low humidity, preferably in dry locations or in confined liners.
- Covered areas, like malls, distribution centers, grocery stores, wholesalers, hospitals, etc.

Acabamento para o Aço Carbono

Finishing for Carbon Steel

GALVANIZADO ELETROLÍTICO (GE) NBR-10476

ELECTROLYTIC GALVANIZED (GE) NBR 10476

Galvanização eletrolítica é um processo de eletrodeposição, denominado galvanoplastia. Trata-se de um processo de revestimento de materiais condutores ou não-condutores, por metais a partir de uma solução contendo íons destes metais.

Basicamente, o processo de galvanoplastia envolve uma sequência de banhos consistindo em etapas de pré-tratamento de revestimento e de conversão de superfície. Entre estas etapas as peças sofrem um processo de lavagem.

O processo eletrolítico consiste em revestir superfícies de peças de aço com outros metais mais nobres, neste caso o zinco. Este processo tem como objetivo proteger uma peça metálica da corrosão, bem como conferir melhor acabamento estético ou decorativo à mesma. Podemos definir galvanoplastia como a tecnologia responsável pela transferência de íons metálicos de uma dada superfície sólida ou meio líquido denominado eletrólito para outra superfície, seja ela metálica ou não. Este processo usa a corrente elétrica, sendo chamado de eletrólise.

Neste processo de galvanoplastia ou galvanização eletrolítica, as chapas de aço recebem uma camada de aproximadamente 2,5 a 8 microns de zinco.

INDICAÇÃO DE USO - Este tipo de acabamento e proteção é mais indicado para:

- Locais internos, sem presença de umidade;
- Áreas cobertas, normalmente confinadas em nichos fechados por forro.

Electrolytic galvanized is an electrodeposition process, called galvanoplasty. It is a coating process of conductors or non-conductors materials, by metals from a solution with ions of these materials.

Essentially, galvanoplasty process involves a sequence of baths, consisting in steps of pre-treatment of the coating and of surface conversion. Between these steps, the pieces undergo a washing process.

The electrolytic process consists in coat steel surfaces with others nobler metals, in this case with zinc. This process aims to protect a metal piece of corrosion, as well as check the best aesthetic or decorative finish. We can define galvanoplasty as the responsible technology for metal ions transfer of one solid surface or of a liquid called electrolyte, to another surface, a metal one or not. This process use the electric current, so it is called electrolysis.

In this galvanoplasty process or electrolytic galvanized, the steel plate receive a coat approximately 2.5 to 8 microns of zinc.

INDICATION OF USE - This type of finishing and protection is best suited for the conditions listed below:

- Internal use with no humidity;
- Covered areas, usually confined in niches closed by liner.

Acabamento para o Aço Carbono

Finishing for Carbon Steel

PINTURA ELETROSTÁTICA (PT)

ELECTROSTATIC PAINTING (PT)

A pintura eletrostática ou lacagem é um processo de pintura, que tem como finalidade o revestimento da chapa de aço, alumínio ou outros metais com uma película de polímero termo-endurecível colorido (pó de poliéster). Existem várias cores que podem ser utilizadas.

Este processo de pintura garante a flexibilidade da peça sem ofender a pintura. Quando a peça é pintada a tinta recebe uma carga elétrica oposta a da peça, fazendo com que a tinta se fixe na peça. Após este procedimento a peça é levada a uma estufa onde a tinta é aquecida para que se dê a cura da mesma e se fixe na peça desejada. Esta modalidade pode também ser usada para dar um melhor acabamento e apurar a estética do produto final ou reforçar a resistência contra a corrosão. Por diversas vezes, a pintura eletrostática já foi utilizada em acabamentos como galvanizados à fogo, galvalume, pré-zincados e eletrolíticos, bem como em materiais mais nobres como o aço inox e alumínio.

Neste processo de pintura eletrostática, as chapas de aço recebem uma camada de aproximadamente 50 à 60 microns de tinta.

INDICAÇÃO DE USO - Este tipo de acabamento e proteção é mais indicado para:

- Locais internos, onde o acabamento estético tem prioridade
- Prédios de shoppings centers, grandes redes de supermercados, atacadistas, grandes magazines e locais onde este tipo de material fica totalmente aparente e exposto ao olhar do público em geral.

The electrostatic painting or lacquering is a painting process that aims coat the steel or aluminum plate or other metal surface with a pellicle of colored thermosetting polymer (polyester powder). Many colors can be used.

This painting process ensures flexibility to the piece without damaging part of the painting. When painting the piece, the ink receive an opposite electrical charge, making the ink stay on the piece. After this proceeding, the piece remains in a kiln, which warm the ink to make ink curing, so it stays on the surface of the wanted piece.

This modality can also be used to give a better finish and verify the aesthetics of the final product, or enhance corrosion resistance. On several occasions, the electrostatic painting has been used in finish like hot dip galvanized, Galvalume®, pre-zincs and electrolytic, as well as nobler materials like stainless steel and aluminum.

In this process of electrostatic painting, the steel plate receive a coat approximately 60 to 70 microns of ink.

INDICATION OF USE - This type of finishing and protection is best suited for the conditions listed below:

- Internal use, where the priority is aesthetic finish.
- Malls buildings, large grocery stores chains, wholesalers, large department stores, and locals where this type of material stay fully exposed and seeming to public.

Leitos

Cable trays ladder type



LEITOS		LEITOS		LEITOS	
Código dos Materiais	Ver Página	Código dos Materiais	Ver Página	Código dos Materiais	Ver Página
DP608	28	DP814	16	DP837	19
DP610	28	DP814C	22	DP838	19
DP611	29	DP815	16	DP839	19
DP612	27	DP815C	22	DP840	19
DP613	27	DP816	16	DP841	20
DP614	27	DP816C	22	DP842	20
DP618	28	DP817	16	DP843	20
DP619	28	DP817C	22	DP843-2	20
DP621	28	DP818	17	DP844	24
DP622	28	DP818C	22	DP845	24
DP747	30	DP819	17	DP846	24
DP748	30	DP819C	22	DP846-1	24
DP800	14	DP820	17	DP847	24
DP802-200	14	DP820C	22	DP848	25
DP802-250	14	DP821	17	DP849	25
DP802-500	14	DP821C	22	DP850	25
DP803-200	14	DP822	17	DP851	25
DP803-250	14	DP822C	23	DP852	25
DP803-500	14	DP823	17	DP853	25
DP804-250	14	DP823C	23	DP853-P	25
DP804-500	15	DP824	17	DP853-C	26
DP805-250	15	DP824C	23	DP853-C2A	26
DP805-500	15	DP825	18	DP853-2A	26
DP806	15	DP825C	23	DP853-FR	26
DP806C	21	DP826	18	DP854	26
DP807	15	DP827	18	DP855	27
DP807C	21	DP827C	23	DP856	27
DP808	15	DP828	18	DP857	27
DP808C	21	DP829	18	DP858	29
DP809	15	DP829C	23	DP859	29
DP809C	21	DP830	18	DP859C	27
DP810	16	DP830C	23	DP860	30
DP810C	21	DP831	18	DP861	29
DP811	16	DP831C	24	DP862	30
DP811C	21	DP832	18		
DP812	16	DP833	19		
DP812C	21	DP834	19		
DP813	16	DP835	19		
DP813C	21	DP836	19		

Anotações

Dispan

Exemplo de como solicitar leitos

How to specify cable tray ladder type.

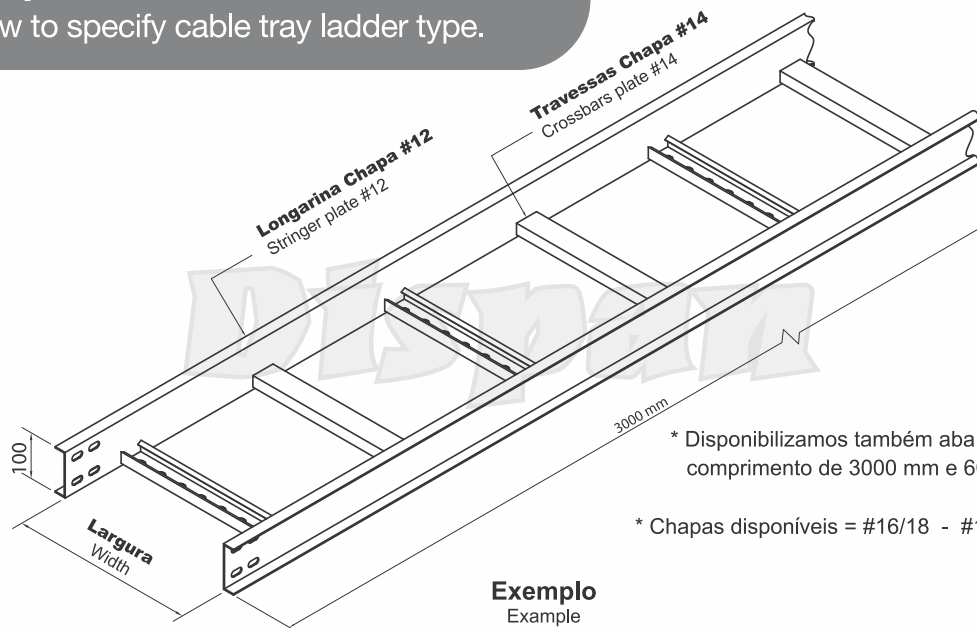

* Disponibilizamos também aba de 150 mm e o comprimento de 3000 mm e 6000 mm.

* Chapas disponíveis = #16/18 - #14/16 - #12/14

Exemplo
Example

DP 803-250 - AC - GF - AE - 400 - 12/14

Referência do catálogo de produtos com características básicas

Product catalog reference with basic features

Matéria-prima de fabricação

Manufacturing raw material

Acabamento

Finish

Posicionamento das abas

Positioning tabs

Largura do leito

Width of the cable tray ladder

Chapas de construção do leito

Plate construction of the cable tray ladder

DP 803 • Leito semipesado, longarina com 100 mm de altura e virola de 19 mm com travessas a cada 250 mm, em perfilado de 38 x 19 mm.

DP 803 • semi heavy cable tray ladder, stringer with 100 mm height and ferrule of 19 mm with crossbars in each 250 mm, profiled in 38 x 19 mm.

Matéria-prima base

Raw material base

AC - Aço carbono

Carbon Steel

AI - Aço inox

Stainless Steel

AL - Alumínio

Aluminum

Acabamento aplicado na matéria-prima em base de aço carbono

Finish applied to the raw material in carbon steel base

GF - Galvanizado à fogo por imersão

Hot dip galvanized

GE - Galvanizado eletrolítico

Electrolytic galvanized

PZ - Pré-zincado (cravado)

Pre-zincated (locked)

NT - Natural

Natural

PT - Pintado

Painting

Posição das abas

AE - com aba externa

External tabs

AI - com aba interna

Internal tabs

Largura: 400 - Largura do leito desejado (De 100 a 1500 mm).

Width: 400 – width of the wanted cable tray ladder (100 to 1500 mm).

Espessuras de chapas: 12 - Chapa das longarinas | 14 - Chapa das travessas

Plate thickness: 12 - stringers plate | 14 - crossbars plate

Descritivo técnico | Technical description

DP 803-250 • Leito semipesado com longarina de 100 mm de altura e virola de 19 mm, com travessas distanciadas a cada 250 mm, em perfilado de 38 x 19 mm em aço carbono galvanizado à fogo, aba externa, largura de 400 mm com longarinas em chapa #12 e travessas em chapa #14.

DP 803-250 • semi heavy cable tray ladder with 100 mm of height stringer and ferrule of 19 mm, with crossbars set 250 mm apart each, profiled in 28 x 19 mm of carbon steel hot dip galvanized, external tab, width of 400 mm with stringers plate #12 and crossbars plate #14.

ATENÇÃO!

A DISPAN INDÚSTRIA E COMÉRCIO não recomenda o uso de leito ou eletrocalha como passarela, escada ou apoio para pessoas. USE APENAS PARA PASSAGEM DE CABOS.

UTILIZE OS EPI'S CONFORME NR-06 E SIGA AS PRÁTICAS DE SEGURANÇA NO TRABALHO, COMO DESCRITO NA NR-10 E NR-35.

Nota

Ocasionalmente podem ocorrer algumas distorções de medidas em nossas peças, por diversos fatores. Por este motivo damos uma tolerância de 5,0 mm entre as medidas mencionadas no catálogo e as peças reais. Os furos oblongos são feitos exatamente para compensação e ajuste de eventuais diferenças.

WARNING!

DISPAN Industry and Trade does not recommend using cable trays or bed ladder as walkway, stair or support for people. USE ONLY FOR PASSING OF CABLES.

USE THE PPIS AS THE NR-06 AND FOLLOW THE WORK SAFETY PRACTICES AS DESCRIBED IN NR-10 AND NR-35.

Note

Occasionally, it may occur some distortion of measures in our pieces, for several reasons. Because of this, we give a toleration of 5.0 mm between the measures mentioned in this catalog and the real pieces. The slotted holes are made just for clearing and settling of any possible differences.



Como solicitar conexões para leitos

How to specify connections for cable ladder type.

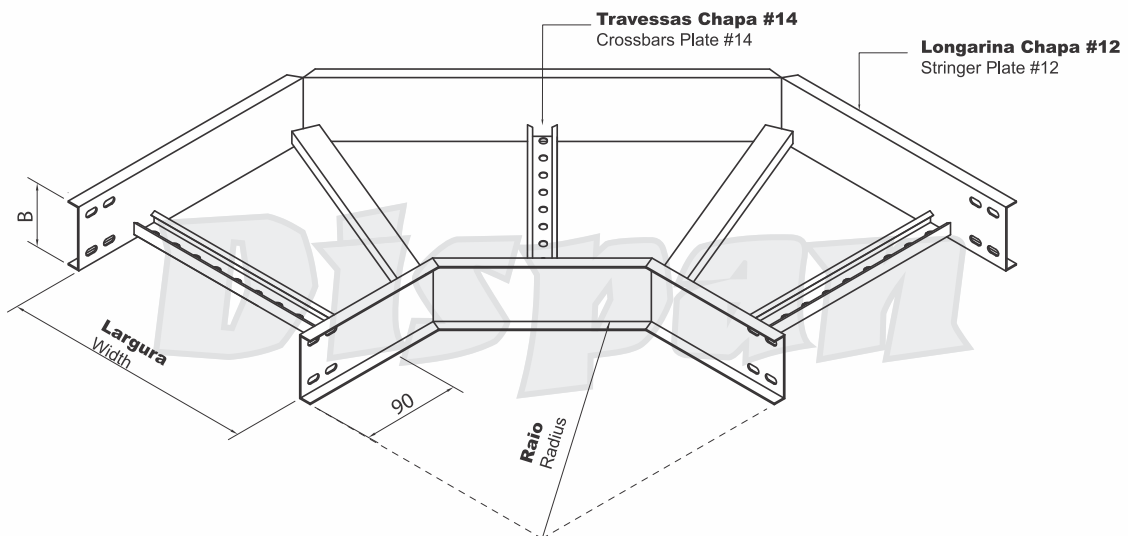

Exemplo
Example

DP811 / 803-250 - AC - GF - AE - 400 - 12/14 - R 320

Referência do catálogo de produtos com características básicas
Product catalog reference with basic features

Modelo do leito
Model of cable ladder

Matéria-prima de fabricação
Manufacturing raw material

Acabamento
Finish

Posicionamento das abas
Positioning tabs

Largura do leito
Width of the cable tray ladder

Chapas de construção do leito
Plate construction of the cable tray ladder

Raio 320 ou 520
Radius 320 or 520

* Para solicitação da tampa, colocar o código + a letra "T": Exemplo = DP811T

DP 811 • Curva Horizontal 90°
DP 811 • Horizontal bend 90°

Matéria-prima base
Raw material base

AC - Aço carbono
Carbon Steel

AI - Aço inox
Stainless Steel

AL - Alumínio
Aluminum

Acabamento aplicado na matéria-prima em base de aço carbono
Finish applied to the raw material in carbon steel base

GF - Galvanizado à fogo por imersão
Hot dip galvanized

GE - Galvanizado eletrolítico
Electrolytic galvanized

PZ - Pré-zincado (cravado)
Pre-zincated (locked)

NT - Natural
Natural

PT - Pintado
Painting

Posição das abas

AE - com aba externa
External tabs

AI - com aba interna
Internal tabs

Largura: 400 - Largura do leito desejado (De 100 a 1500 mm).

Width: 400 – width of the wanted cable tray ladder (100 to 1500 mm).

Espessuras de chapas: 12 - Chapa das longarinas | 14 - Chapa das travessas

Plate thickness: 12 - stringers plate | 14 - crossbars plate

Descritivo técnico | Technical description

DP 811 • Curva horizontal 90° para o leito DP 803-250 em aço carbono, galvanização à fogo, aba externa, largura de 400 mm, com longarina de 100 mm e virola de 19 mm em chapa #12 e travessas em perfilado de 38 x 19 mm na chapa #14, raio de curvatura de 320 mm, segmentado.

DP 811 • Horizontal bend of 90° to the carbon steel cable ladder DP 803-250, hot galvanized, external tab, width of 400mm, with stringer of 100mm and ferrule of 19mm in plate #12 and profiled crossbars of 38x19mm in plate #14, radius of curvature of 320mm, segmented.

Nota 1

Ocasionalmente podem ocorrer algumas distorções de medidas em nossas peças, por diversos fatores. Por este motivo damos uma tolerância de 5,0 mm entre as medidas mencionadas no catálogo e as peças reais. Os furos oblongos são feitos exatamente para compensação e ajuste de eventuais diferenças.

Note 1

Occasionally, it may occur some distortion of measures in our pieces, for several reasons. Because of this, we give a toleration of 5.0 mm between the measures mentioned in this catalog and the real pieces. The slotted holes are made just for clearing and settling of any possible differences.

Nota 2

As conexões para leito, poderão conter cortes, rasgos e soldas para alívio de dobras e conformações construtivas.

Note 2

Connections for cable ladder may contain cuts, rips and solders, for the relief of folds and constructive conformations.

Leito leve - DP800

Cable trays ladder type.

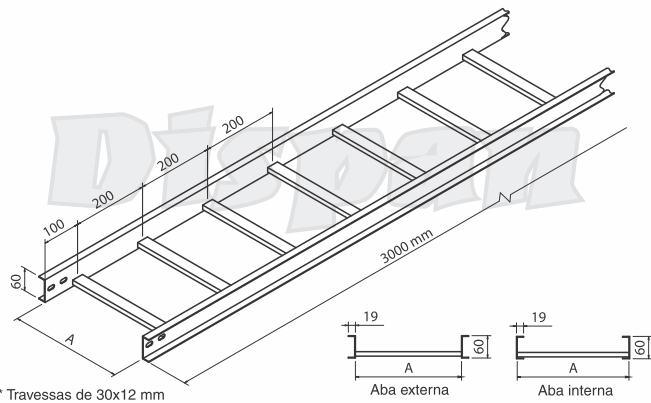

* Travessas de 30x12 mm

Leito semipesado - DP802-200

Cable trays ladder type.

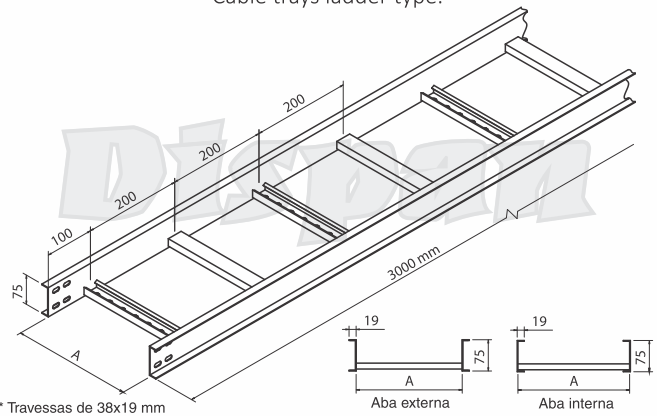

* Travessas de 38x19 mm

Leito semipesado - DP802-250

Cable trays ladder type.

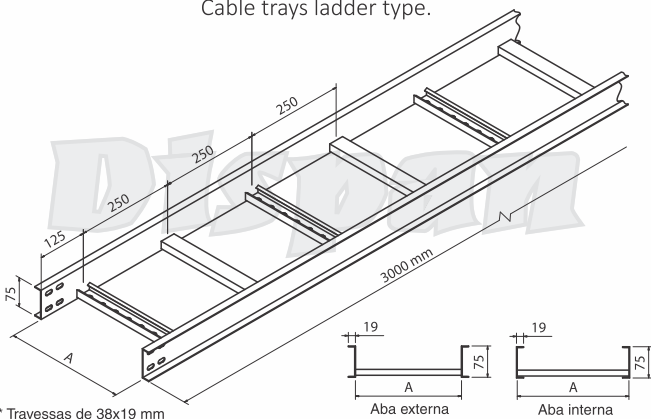

* Travessas de 38x19 mm

Leito semipesado - DP802-500

Cable trays ladder type.

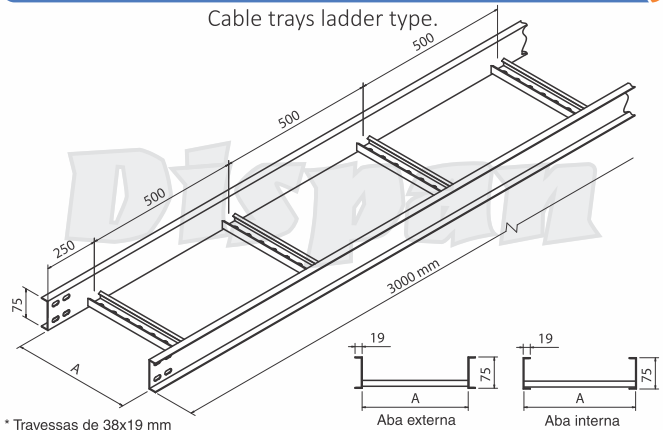

* Travessas de 38x19 mm

Leito semipesado - DP803-200

Cable trays ladder type.

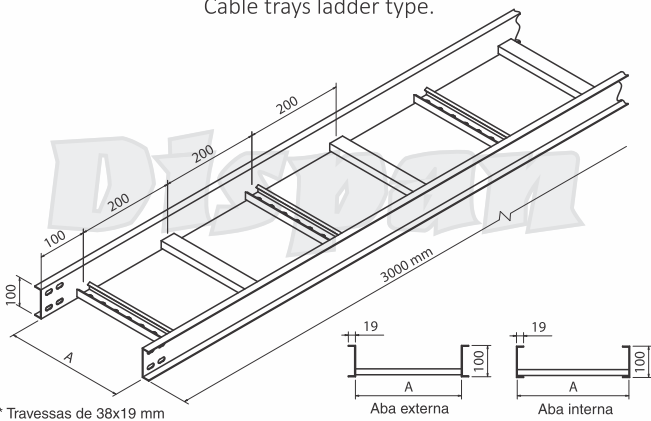

* Travessas de 38x19 mm

Leito semipesado - DP803-250

Cable trays ladder type.

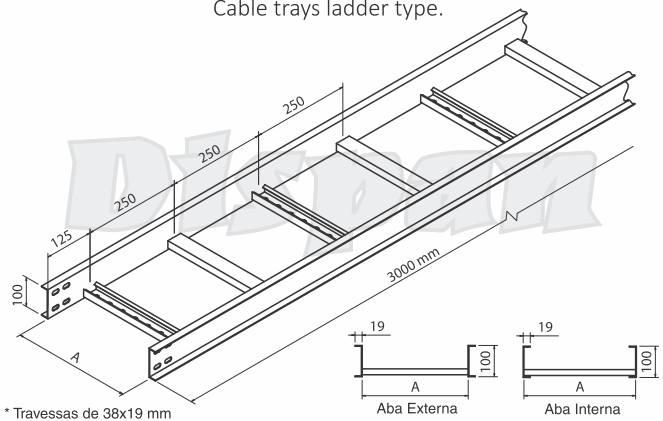

* Travessas de 38x19 mm

Leito semipesado - DP803-500

Cable trays ladder type.

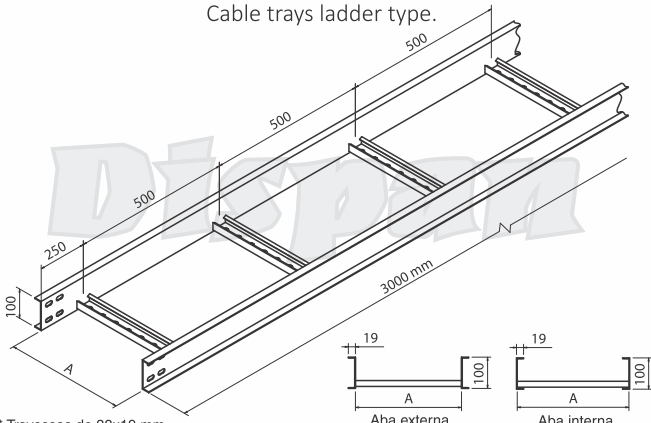

* Travessas de 38x19 mm

Leito pesado - DP804-250

Cable trays ladder type.

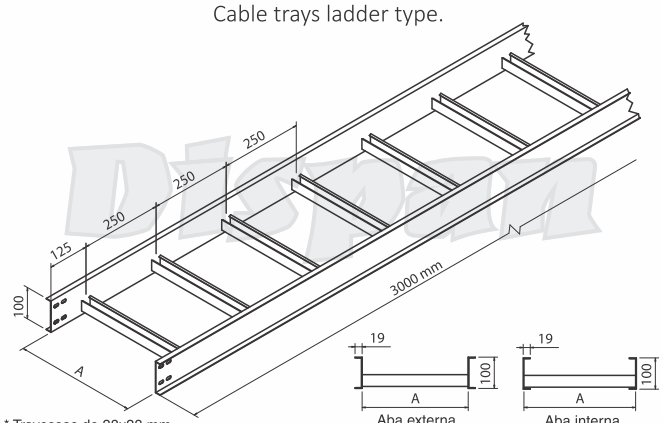

* Travessas de 38x38 mm

Leito pesado - DP804-500

Cable trays ladder type.

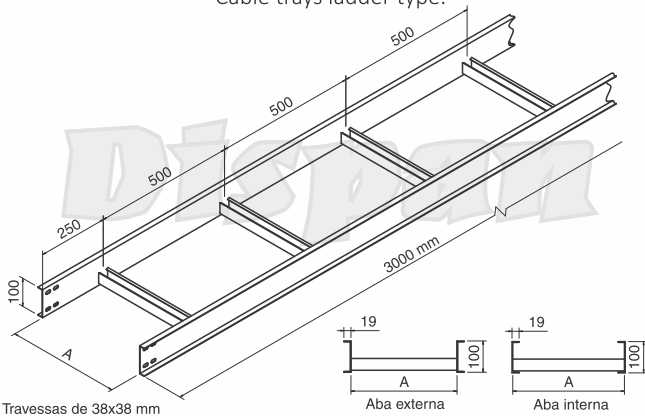

* Travessas de 38x38 mm

Leito super pesado - DP805-250

Cable trays ladder type.

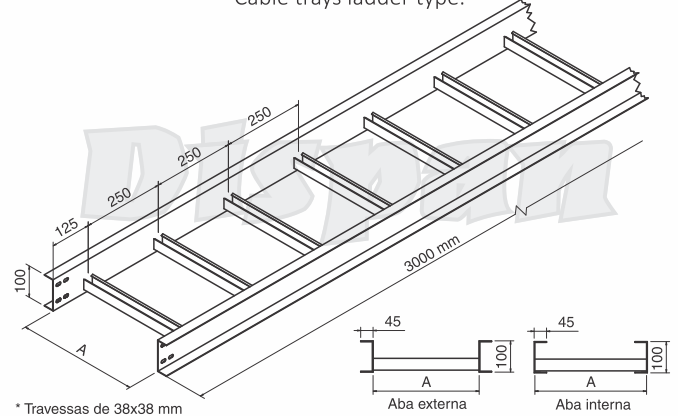

* Travessas de 38x38 mm

Leito super pesado - DP805-500

Cable trays ladder type.

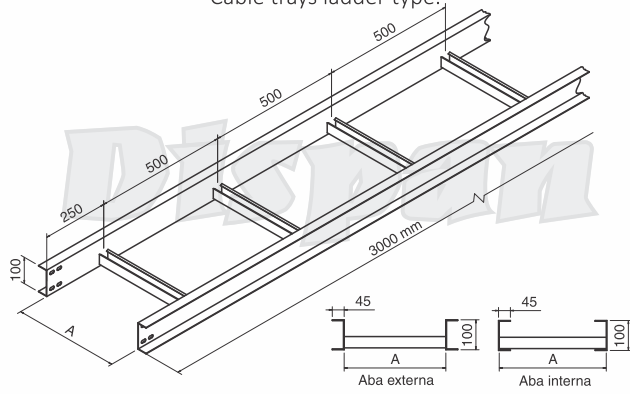

* Travessas de 38x38 mm

Esquema de montagem p/ junção simples

Typical applications.

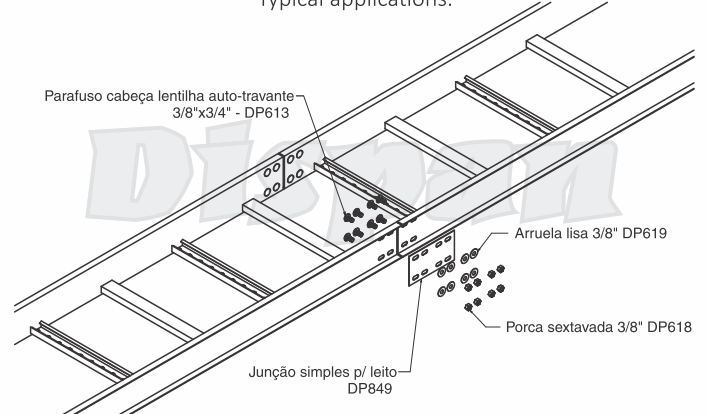

Curva horizontal 15° DP806

Horizontal bend 15°

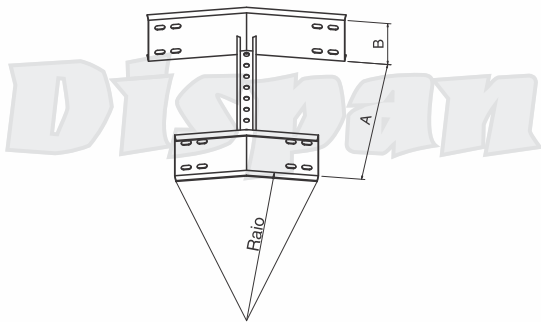

**Conexões
com raio
segmentado**

Curva horizontal 30° DP807

Horizontal bend 30°

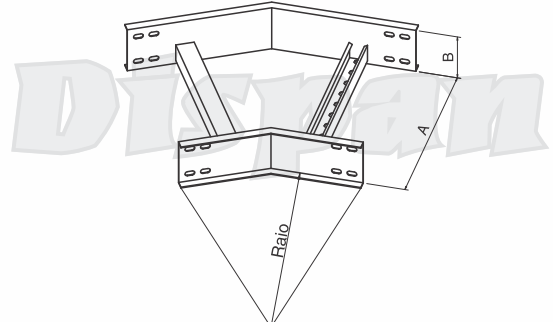

Curva horizontal 45° DP808

Horizontal bend 45°

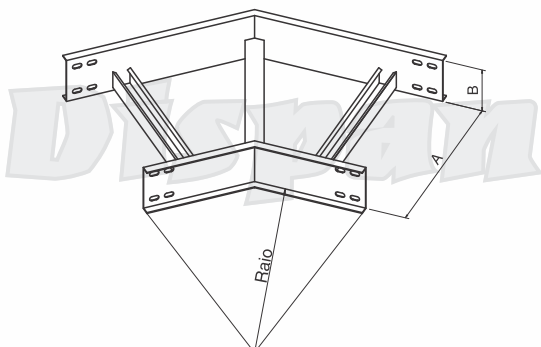

Curva horizontal 60° DP809

Horizontal bend 60°

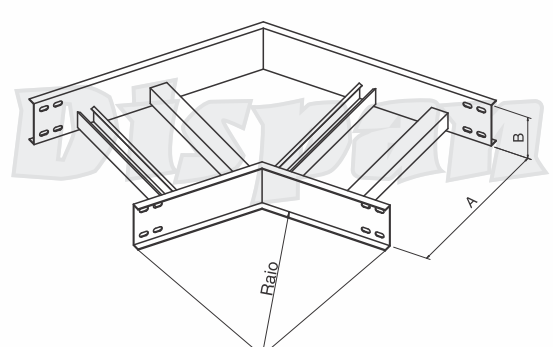

Curva horizontal 75° - DP810

Horizontal bend 75°

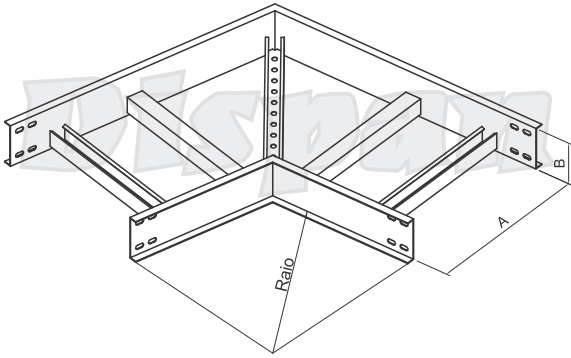

Curva horizontal 90° - DP811

Horizontal bend 90°

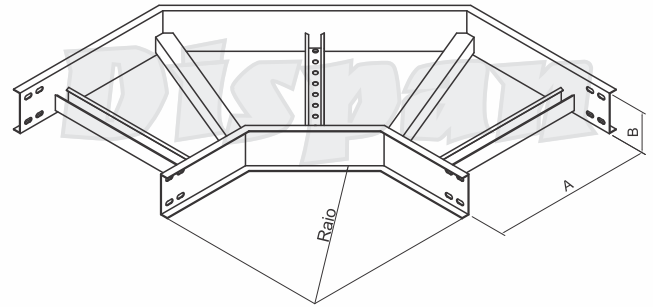

Curva vertical interna 15° - DP812

Vertical inside bend 15°

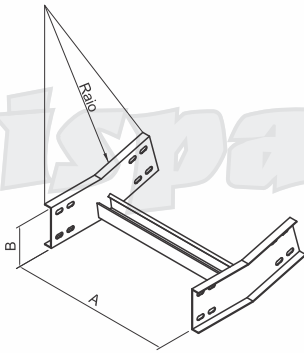

Curva vertical interna 30° - DP813

Vertical inside bend 30°

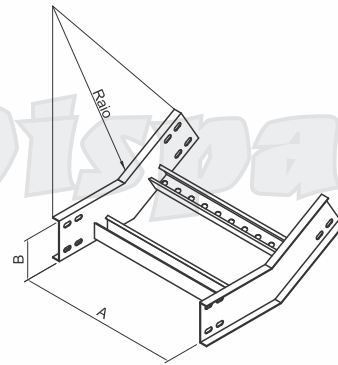

Curva vertical interna 45° - DP814

Vertical inside bend 45°

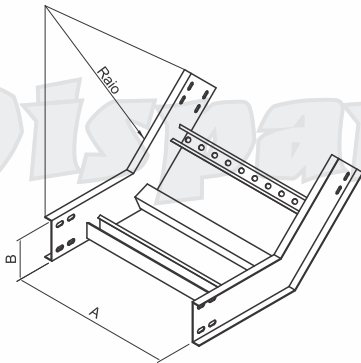

Curva vertical interna 60° - DP815

Vertical inside bend 60°

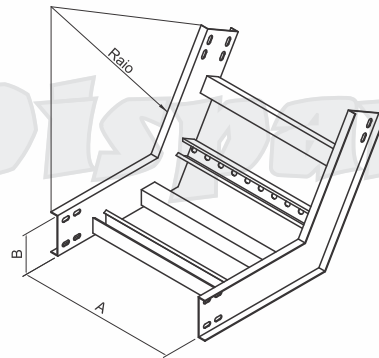

Curva vertical interna 75° - DP816

Vertical inside bend 75°

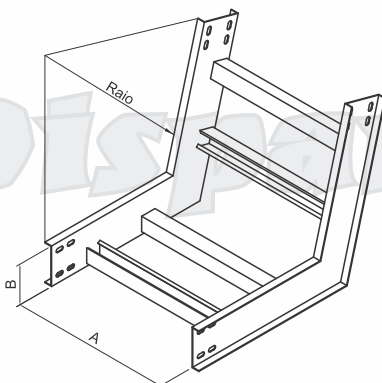

Curva vertical interna 90° - DP817

Vertical inside bend 90°

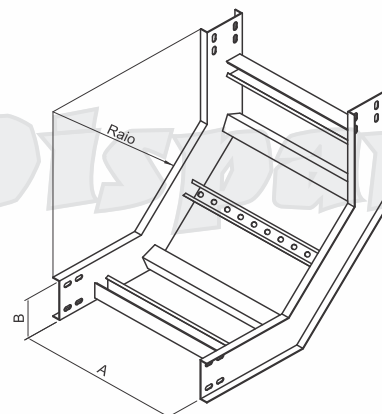

Curva vertical externa 15° - DP818

Vertical outsid bend 15°

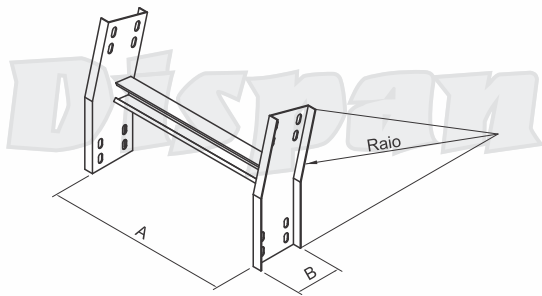

Curva vertical externa 30° - DP819

Vertical outsid bend 30°

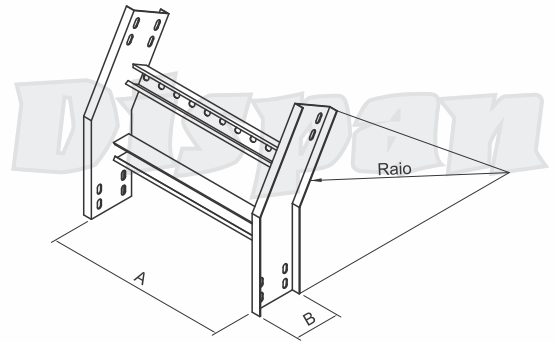

Curva vertical externa 45° - DP820

Vertical outsid bend 45°

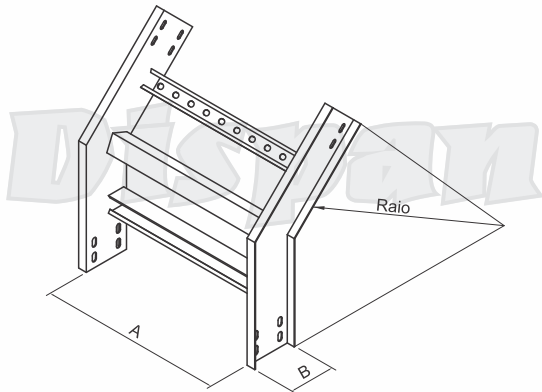

Curva vertical externa 60° - DP821

Vertical outsid bend 60°

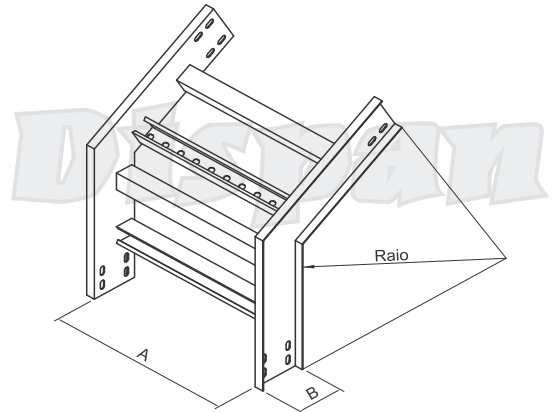

Curva vertical externa 75° - DP822

Vertical outsid bend 75°

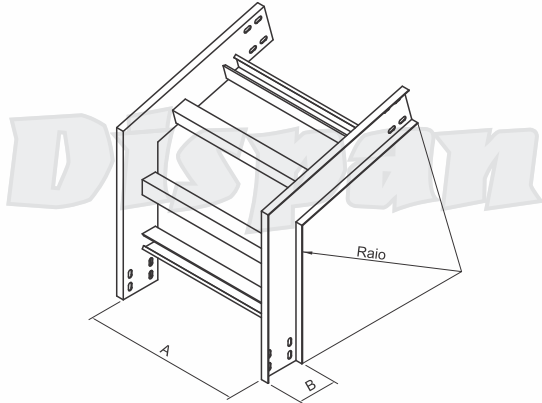

Curva vertical externa 90° - DP823

Vertical outsid bend 90°

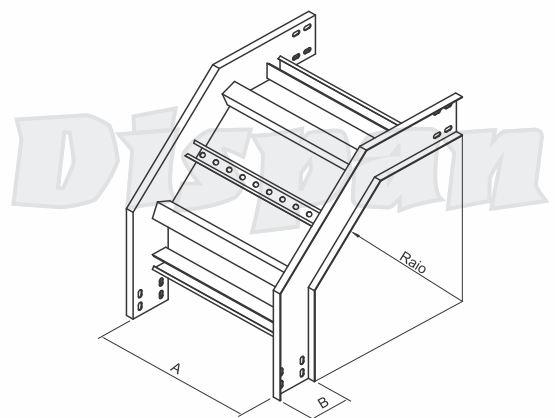

Curva de inversão 90° - DP824

Transitional bends.

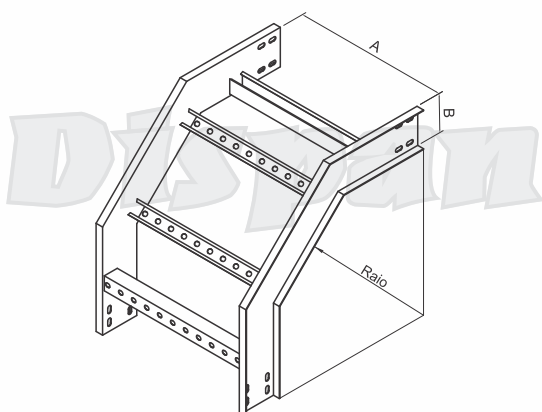

Exemplo de montagem da curva de inversão 90°

Typical applications.

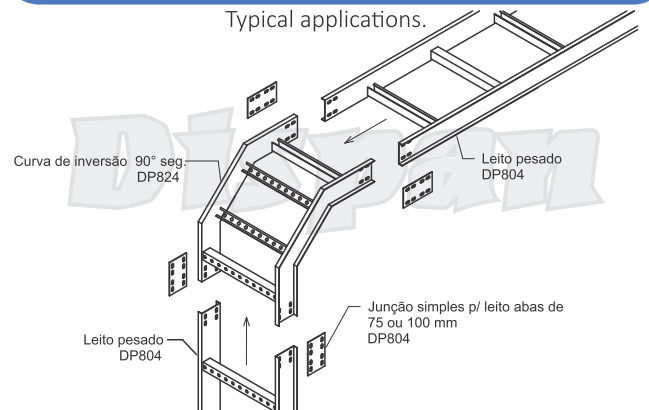

Junção à direita 90° - DP825

Right-hand y-branch.

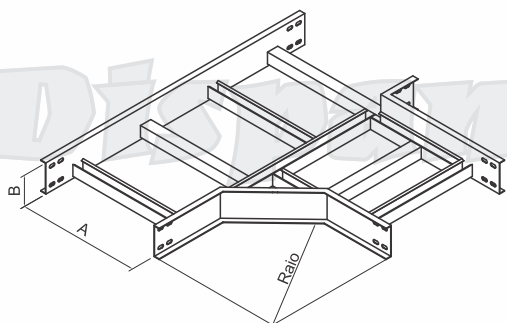

Curva c/ passagem reta de subida - DP826

Bend with ascending straight passage

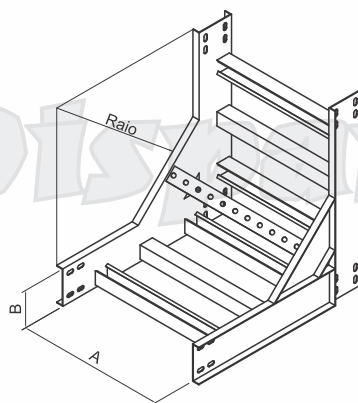

Junção à esquerda 90° - DP827

Left-hand y-branch.

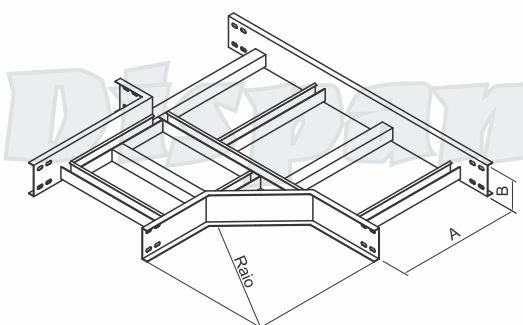

Curva c/ passagem reta de descida - DP828

Bend with ascending straight passage

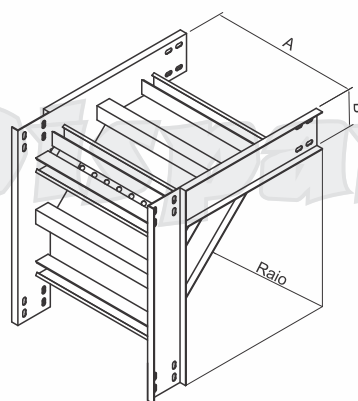

Tê horizontal 90° - DP829

Horizontal tee.

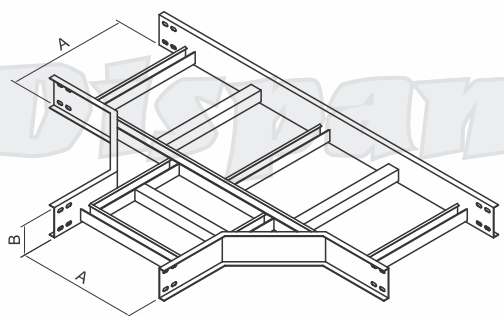

Cruzeta c/ uma saída reta 90° - DP830

Cross with one straight outlet.

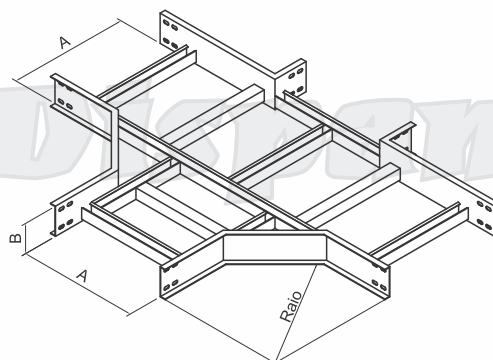

Cruzeta horizontal - DP831

Horizontal cross.

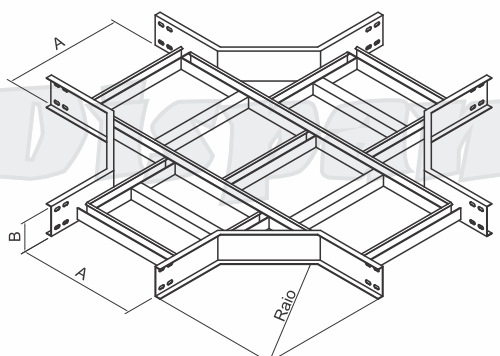

Junção à esquerda 45° - DP832

Left-hand y-branch.

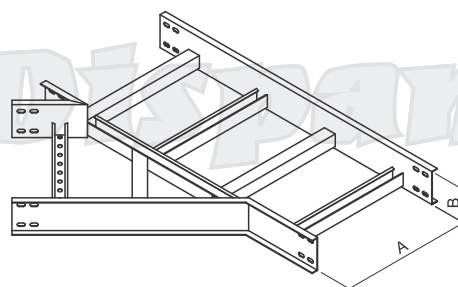

Junção à direita 45° - DP833

Right-hand y-branch.

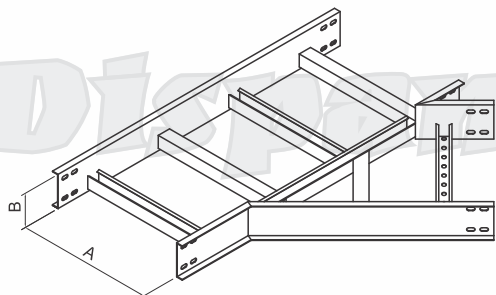

Tê vertical de subida 90° - DP834

Ascending vertical tee.

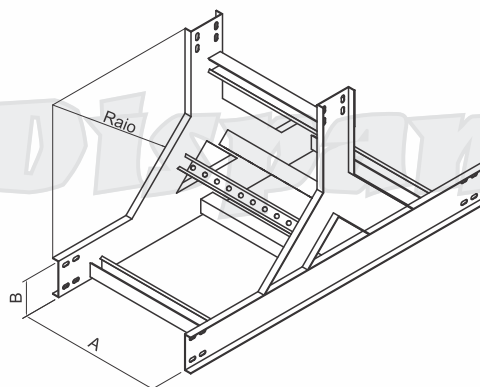

Tê vertical de descida 90° - DP835

Descending vertical tee.

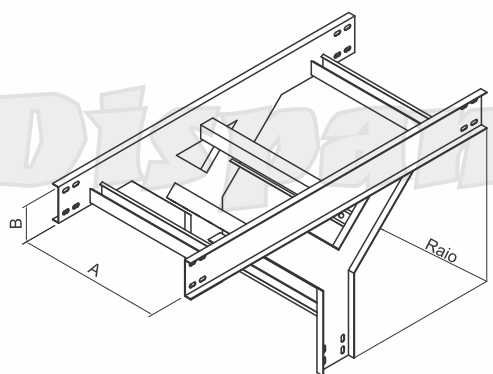

Cotovelo Reto 90° - DP836

90° elbow.

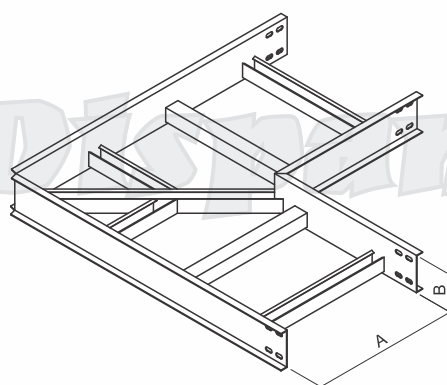

Tê Reto 90° - DP837

Straight tee.

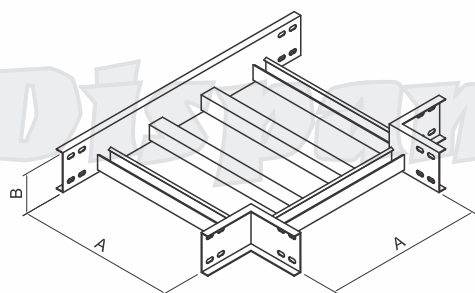

Cruzeta reta 90° - DP838

Straight cross.

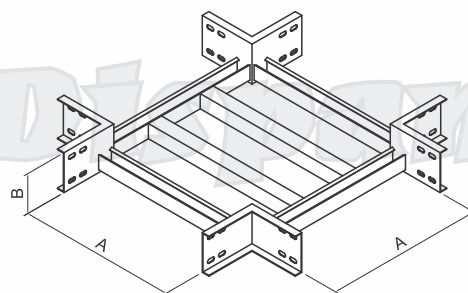

Redução Concêntrica - DP839

Concentric reducer.

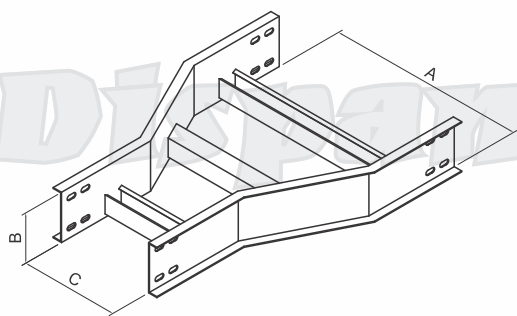

Redução à Direita - DP840

Right-hand reducer.

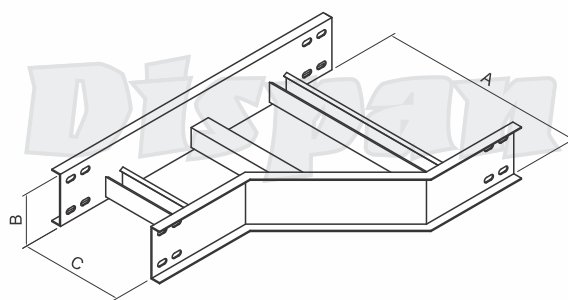

Redução à esquerda - DP841

Left-hand reducer.

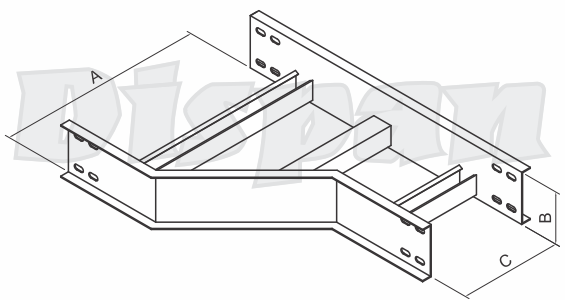

Tê vertical de derivação 90° - DP842

90° lateral vertical descent "T".

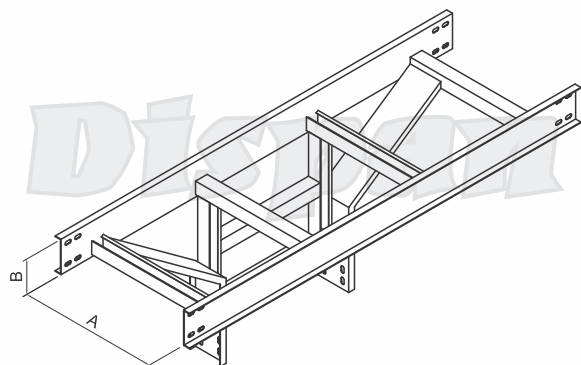

REDUÇÃO RETA CONCÊNTRICA - DP843

Concentric straight reducer.

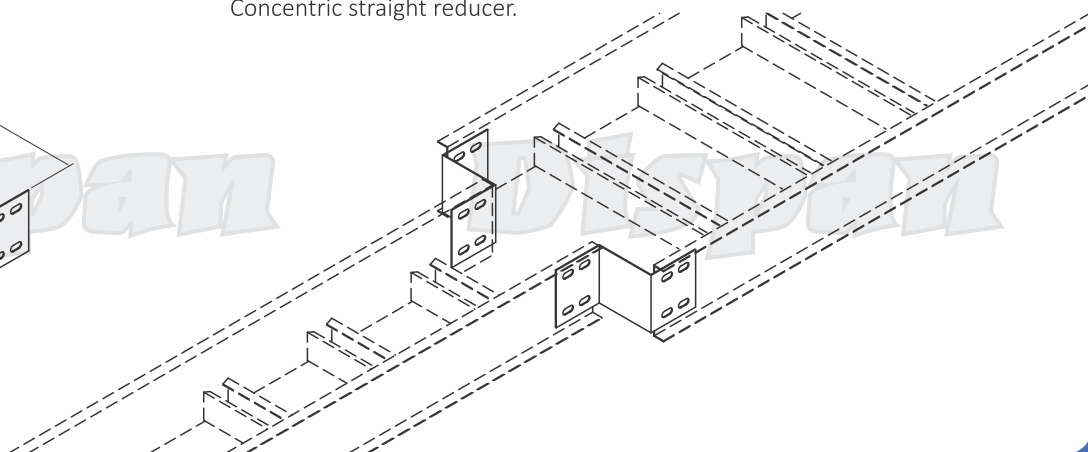
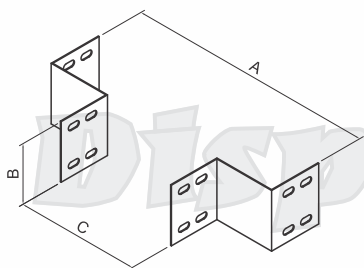

Redução reta excêntrica - DP843-2

Eccentric straight reducer.

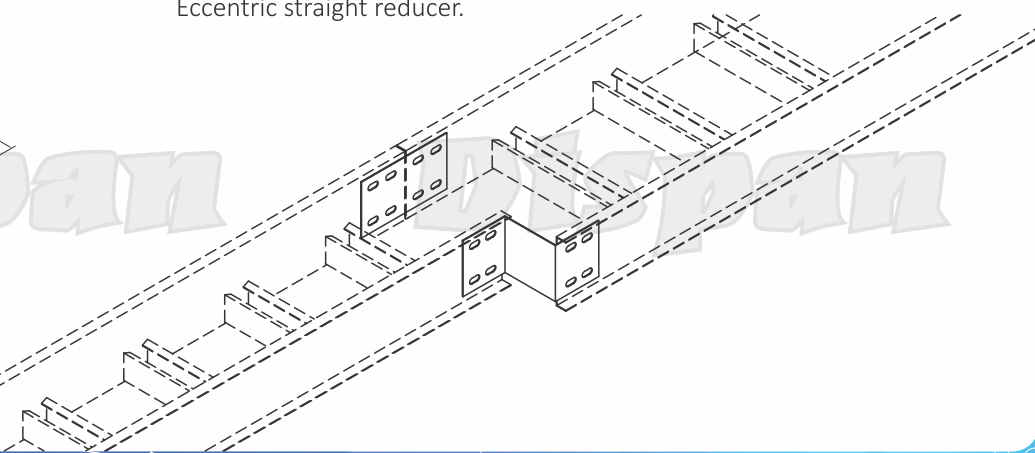
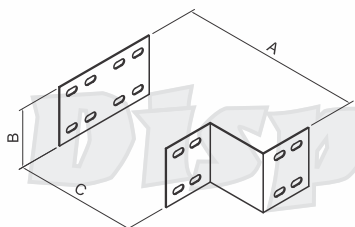

Curva horizontal 15° - DP806C

Horizontal bend 15°

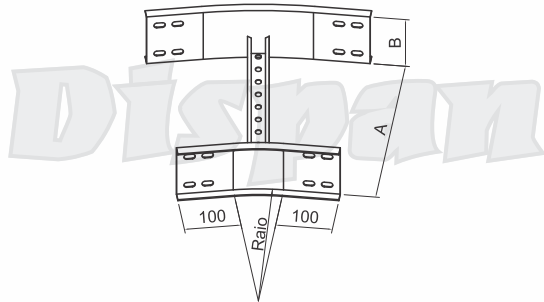

Conexões especiais com raio curvilíneo

Curva horizontal 30° - DP807C

Horizontal bend 30°

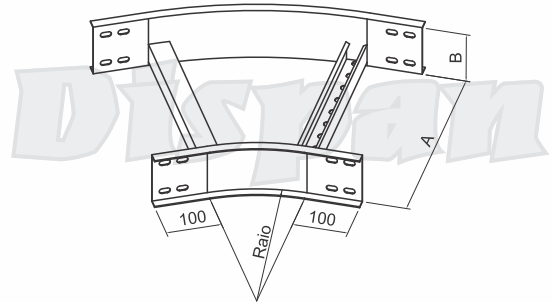

Curva horizontal 45° - DP808C

Horizontal bend 45°

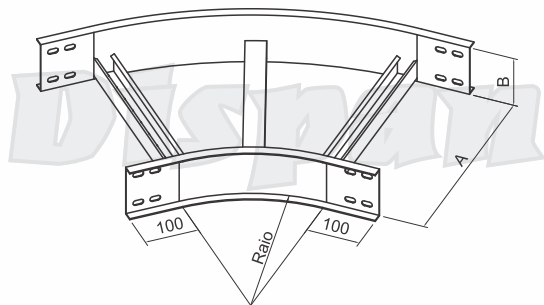

Curva horizontal 60° - DP809C

Horizontal bend 60°

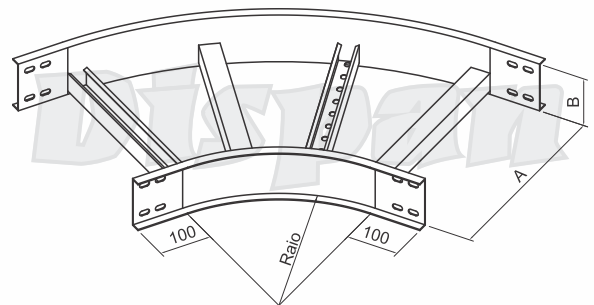

Curva horizontal 75° - DP810C

Horizontal bend 75°

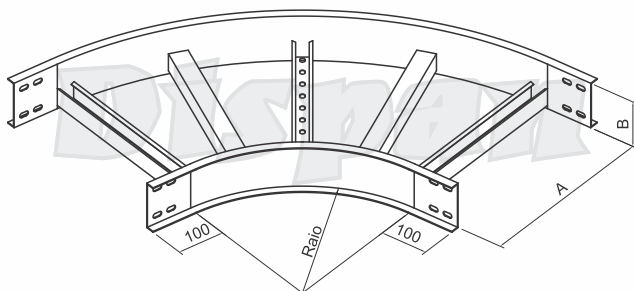

Curva horizontal 90° - DP811C

Horizontal bend 90°

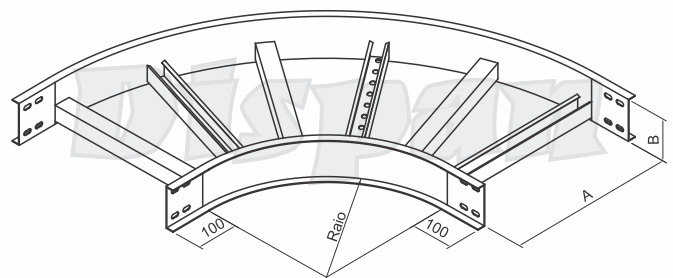

Curva vertical interna 15° - DP812C

Vertical inside bend 15°

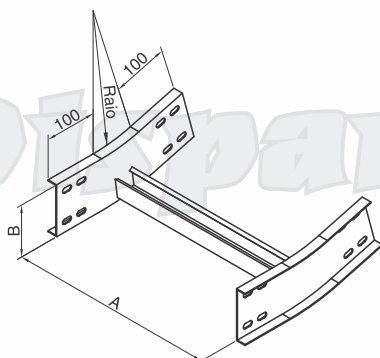

Curva vertical interna 30° - DP813C

Vertical inside bend 30°

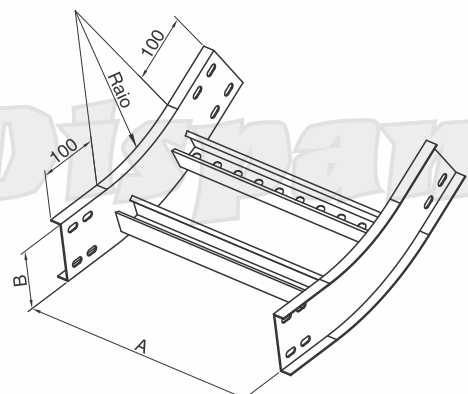

Curva vertical interna 45° - DP814C

Vertical inside bend 45°

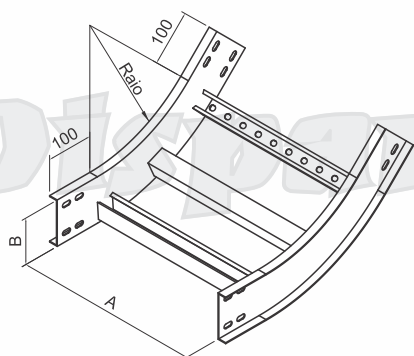

Curva vertical interna 60° - DP815C

Vertical inside bend 60°

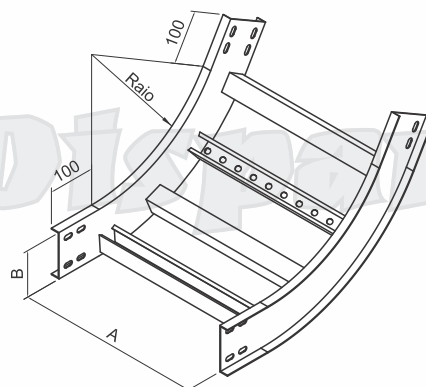

Curva vertical interna 75° - DP816C

Vertical inside bend 75°

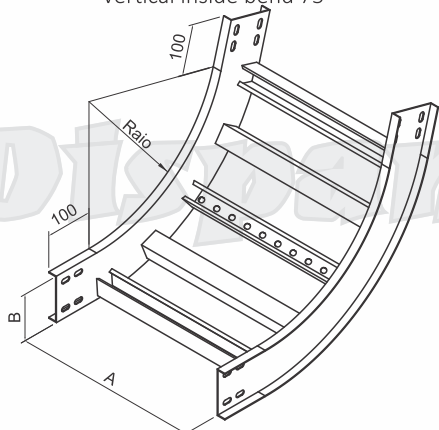

Curva vertical interna 90° - DP817C

Vertical inside bend 90°

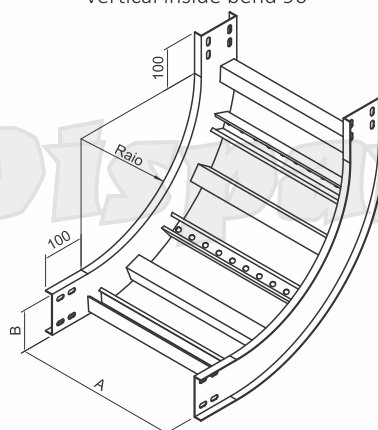

Curva vertical externa 15° - DP818C

Vertical outsid 15°

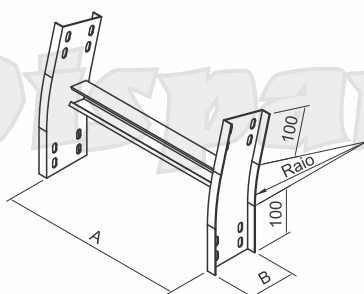

Curva vertical externa 30° - DP819C

Vertical outsid 30°

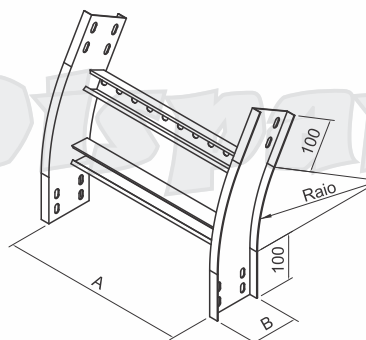

Curva vertical externa 45° - DP820C

Vertical outsid 45°

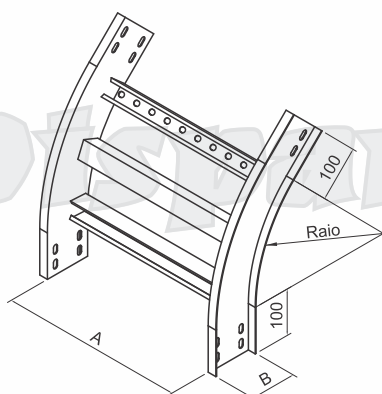

Curva vertical externa 60° - DP821C

Vertical outsid 60°

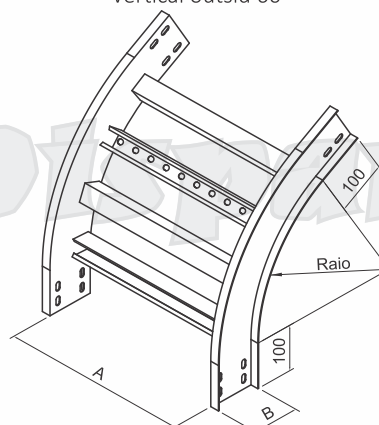

Curva vertical externa 75° - DP822C

Vertical outsid 75°

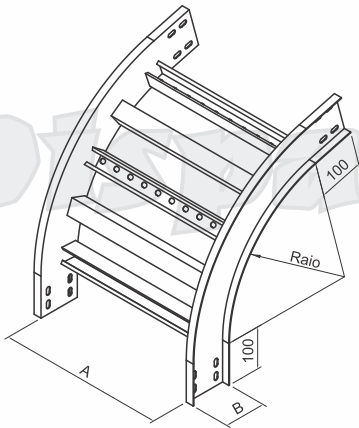

Curva vertical externa 90° - DP823C

Vertical outsid 75°

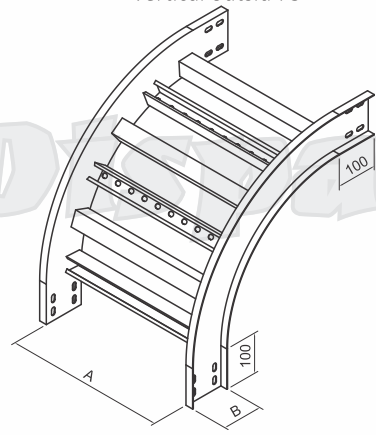

Curva de inversão 90° - DP824C

Transitional bends.

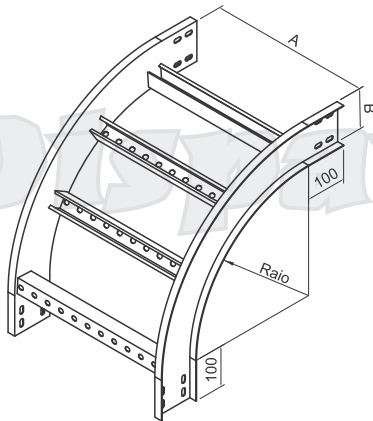

Exemplo de montagem da curva de inversão 90°

Typical applications.

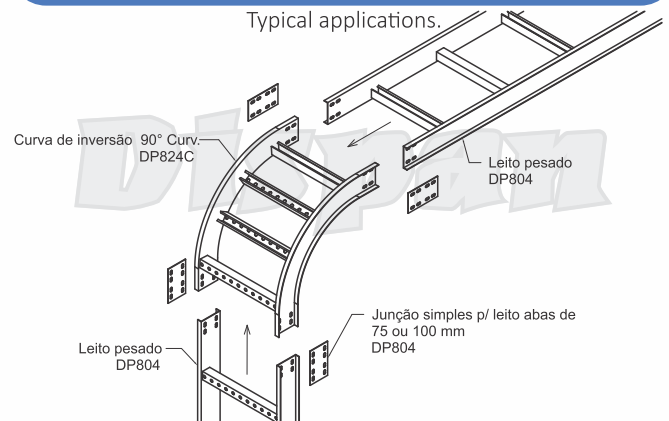

Junção à direita 90° - DP825C

Right- hand y- branch.

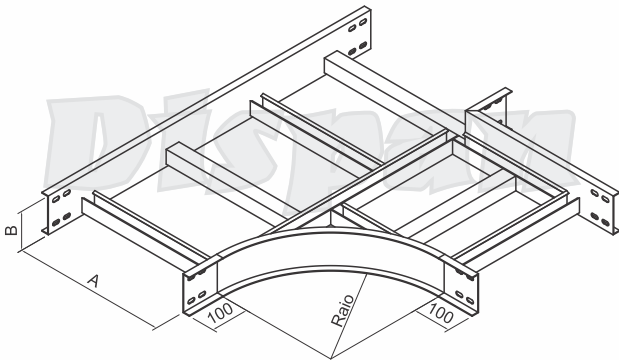

Junção à esquerda 90° - DP827C

Left- hand y- branch.

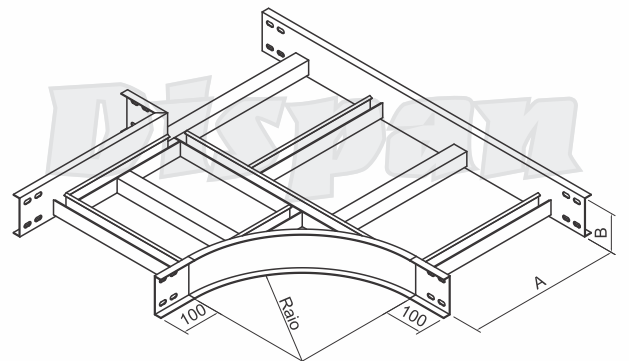

Tê horizontal 90° - DP829C

Horizontal tee.

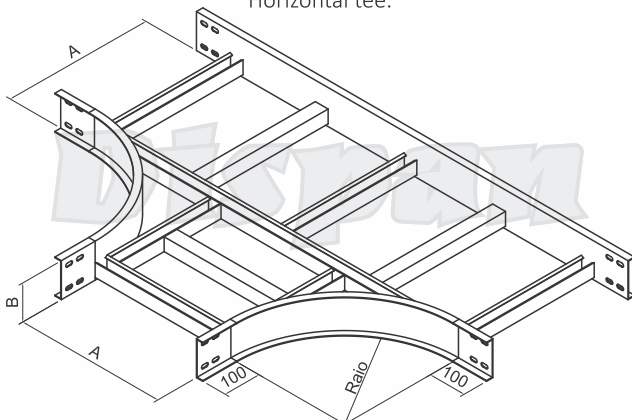

Cruzeta c/ uma saída reta 90° - DP830C

Cross with one straight outlet.

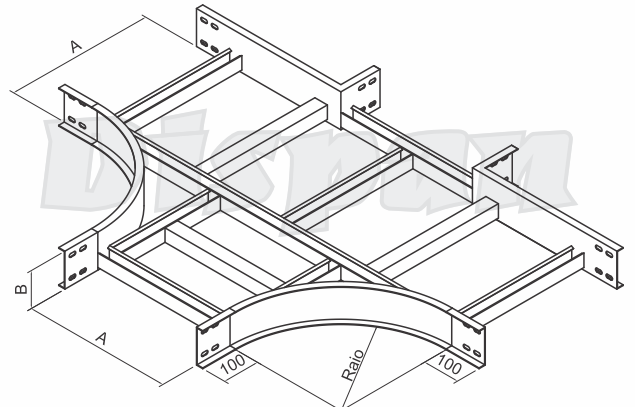

Cruzeta horizontal - DP831C

Horizontal cross.

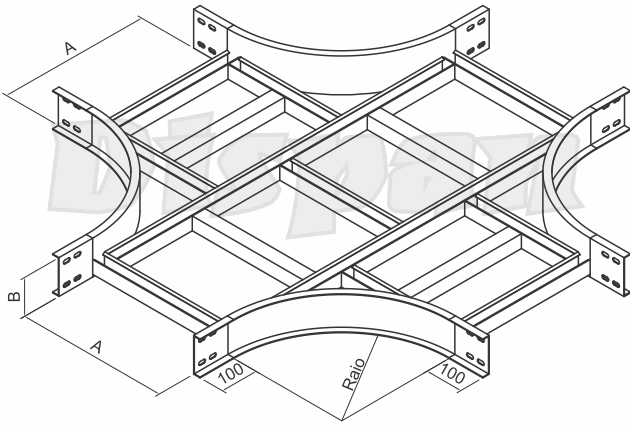

Presilha guia - DP844

Guide saddle.

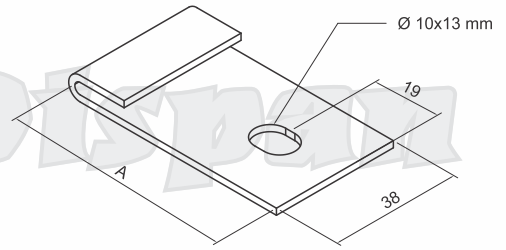

Longarina	A
75 x 19	65
100 x 19	65
100 x 45	90

Esquema de montagem da presilha guia.

Typical applications.

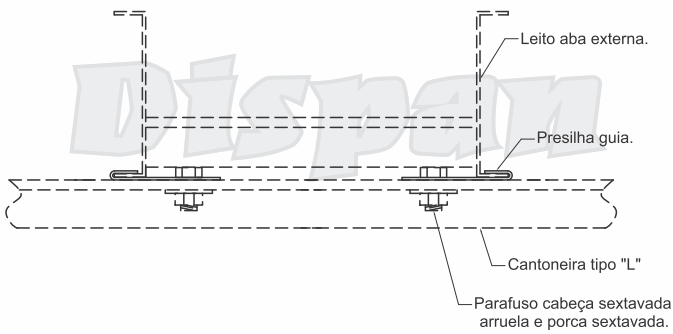

Proteção para ligação em painel - DP845

Box connector.

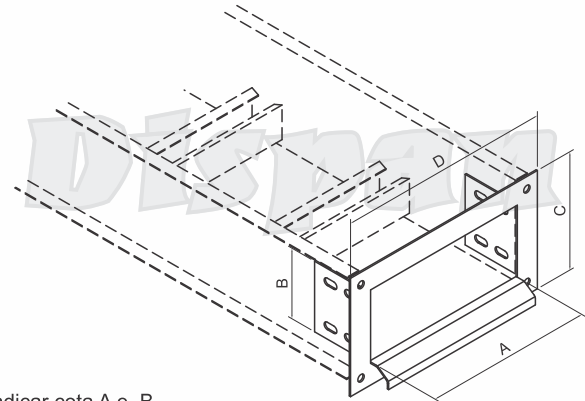

Indicar cota A e B.

Curva vertical articulada - DP846

Ajustable vertical bend.

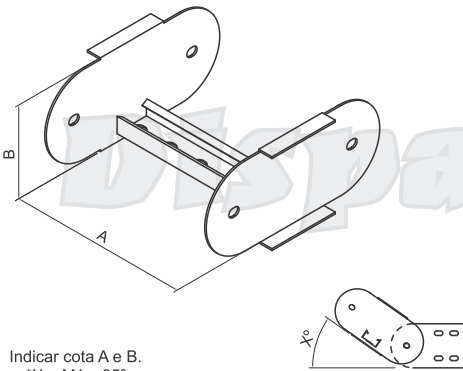

Indicar cota A e B.
*X = Máx. 35°

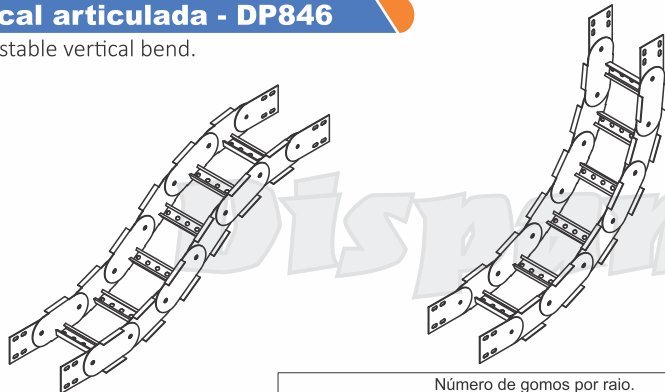

Graus	Número de gomos por raio.						
	15°	25°	30°	45°	60°	75°	90°
Raio 320	1	1	2	2	2	3	4
Raio 520	1	1	2	3	4	5	6

Terminal liso para leito - DP846-1

End plate.

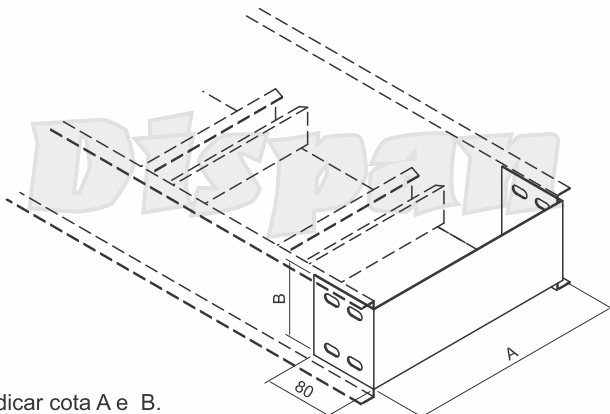

Indicar cota A e B.

Junção simples para aba de 60 mm - DP847

Single splice plate.

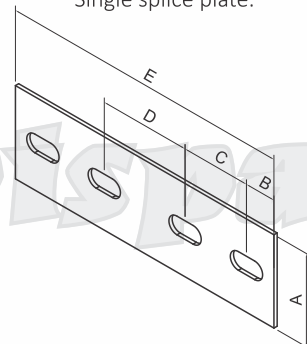

Obs.: Indicado Parafuso lentilha com porca sextavada e arruela lisa de 3/8" x 3/4".

Junção articulada para aba de 60 mm - DP848

Flexible splice.

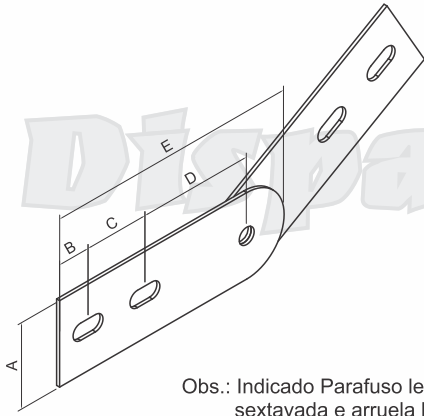

Obs.: Indicado Parafuso lenticular com porca sextavada e arruela lisa de 3/8" x 3/4".

Junção angular 90° para leito aba de 60 mm - DP851

Directional change splice plate.

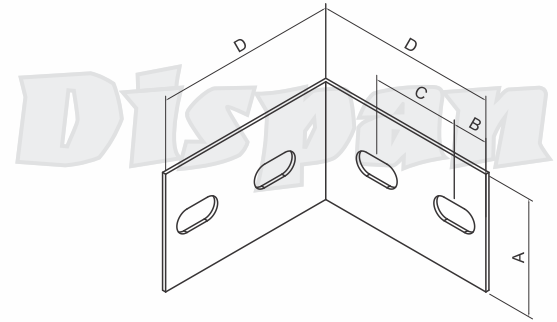

Obs.: Indicado Parafuso lenticular com porca sextavada e arruela lisa de 3/8" x 3/4".

Junção simples p/ leito abas 75 ou 100mm - DP849

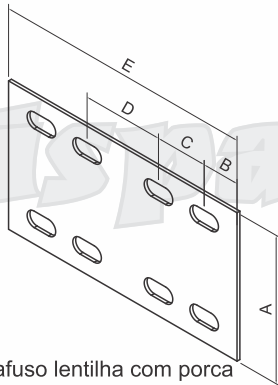

Obs.: Indicado Parafuso lenticular com porca sextavada e arruela lisa de 3/8" x 3/4".

Junção articulada p/ leito abas 75 ou 100 mm - DP850

Flexible splice.

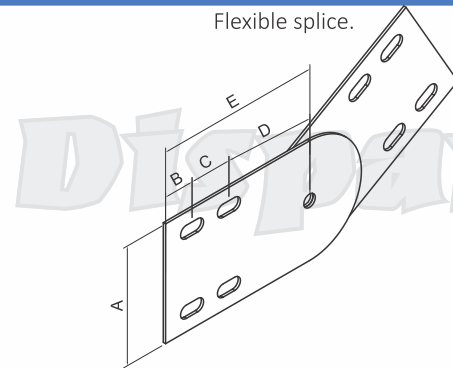

Obs.: Indicado Parafuso lenticular com porca sextavada e arruela lisa de 3/8" x 3/4".

Junção angular 90° p/ leito abas 75 ou 100 mm - DP852

Directional change splice plate.

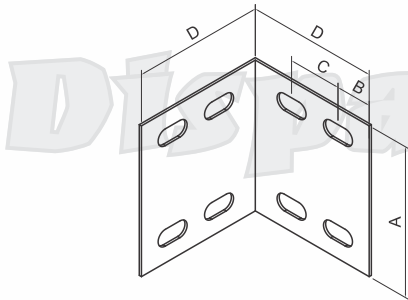

Obs.: Indicado Parafuso lenticular com porca sextavada e arruela lisa de 3/8" x 3/4".

Tampa de encaixe p/ leito - DP853

Cover plate.

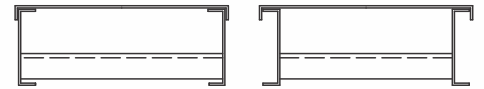
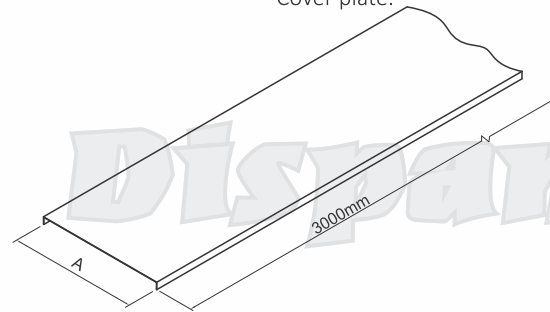

Tampa de pressão para leito - DP853-P

Pressure Cover.

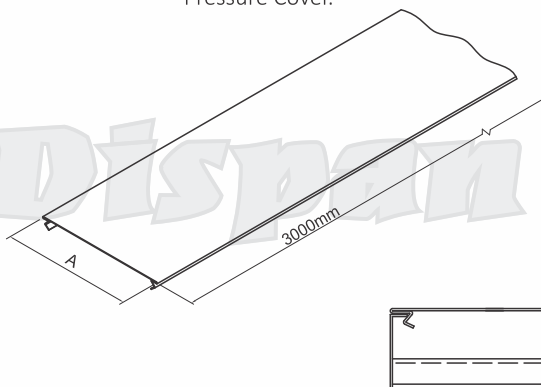

Obs.: Somente para leito aba interna.

Esquema de montagem da tampa de encaixe c/ presilha p/ tampa.

Typical applications.

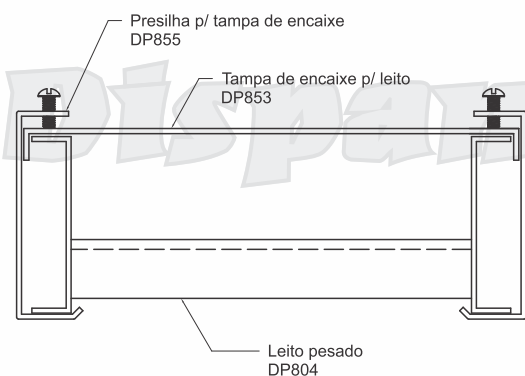

Tampa de encaixe c/ cantoneira p/ leito - DP853-C

Insert cover with corner plate.

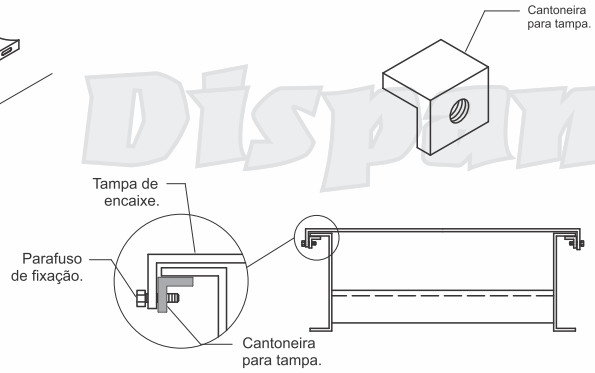
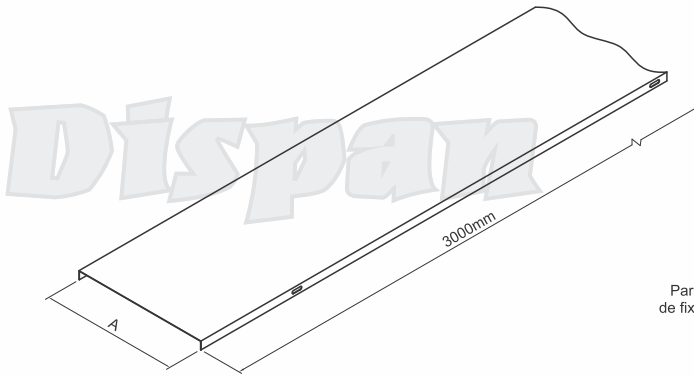

Obs.: As cantoneiras de fixação já acompanham a tampa.

Tampa 2 águas de encaixe c/ cantoneira p/ leito - DP853-C2A

Angular cover with coner plate.

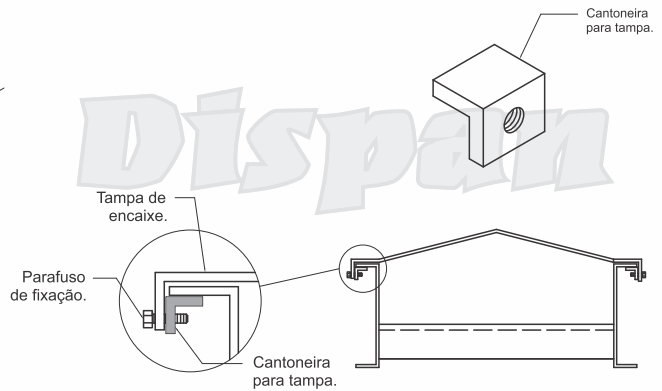
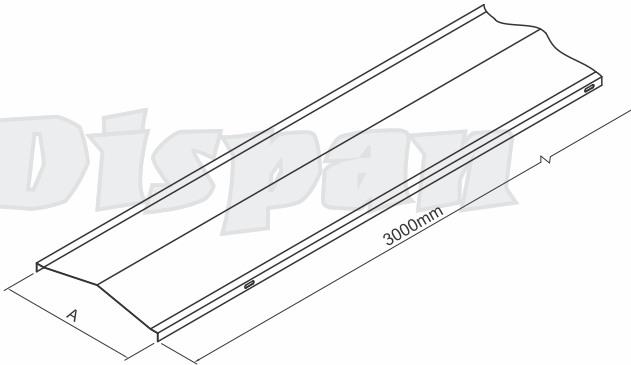

Obs.: As cantoneiras de fixação já acompanham a tampa.
*Não fabricamos tampa 2 águas para conexões.

Tampa 2 águas de encaixe p/ Leito - DP853-2A

Angular cover.

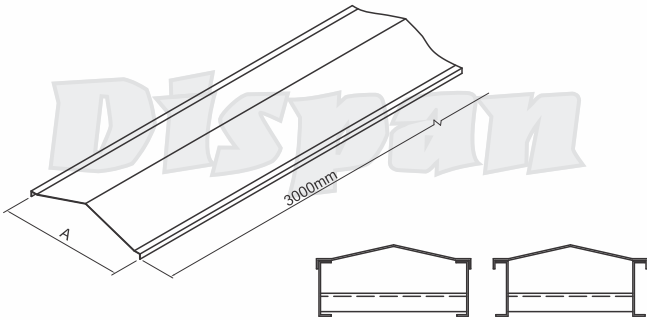

Obs.: Não fabricamos tampa 2 águas para conexões, vide DP859.

Tampa de encaixe c/ fecho rápido p/ leito - DP853-FR

Inserte cover with fast lock.

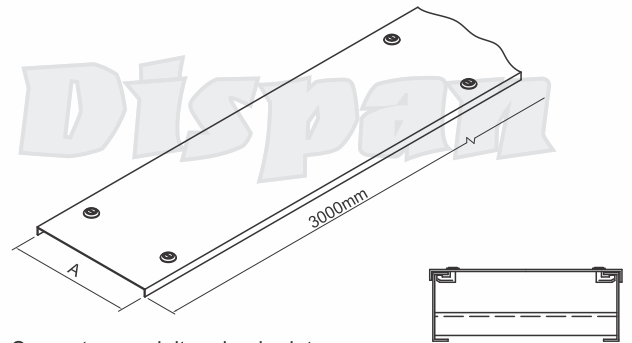

Obs.: Somente para leitos de aba interna.

Septo divisor para leito - DP854

Cable tray divider.

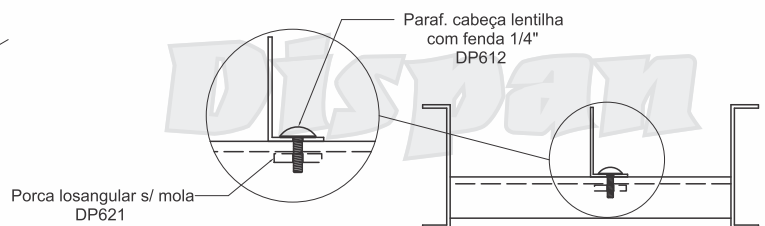
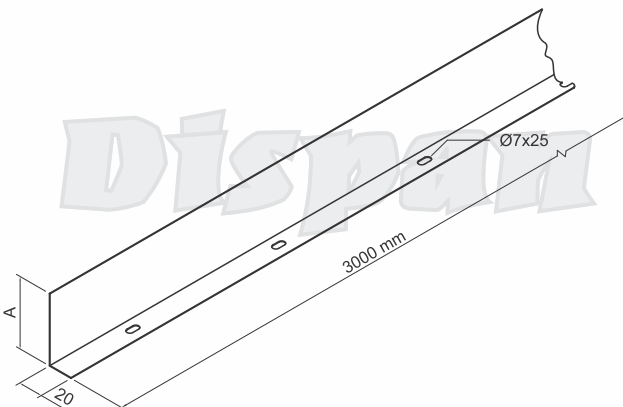

Presilha para tampa de encaixe - DP855

Cover plate beam clamp.

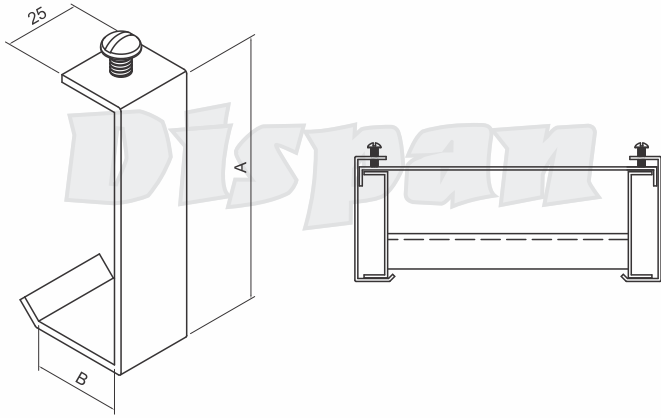

Suporte simples para leito - DP856

Single hanger clip.

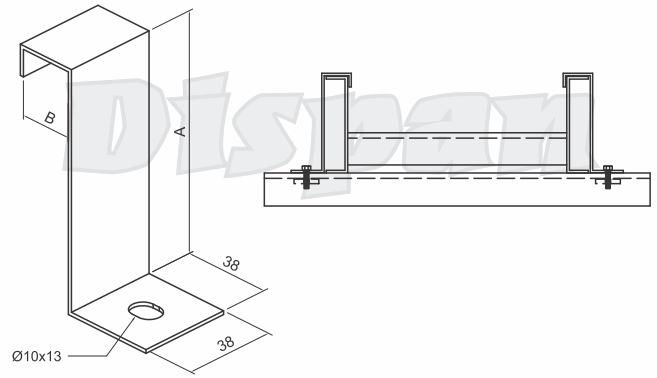

Suporte de suspensão para leito - DP857

Side fastening support.

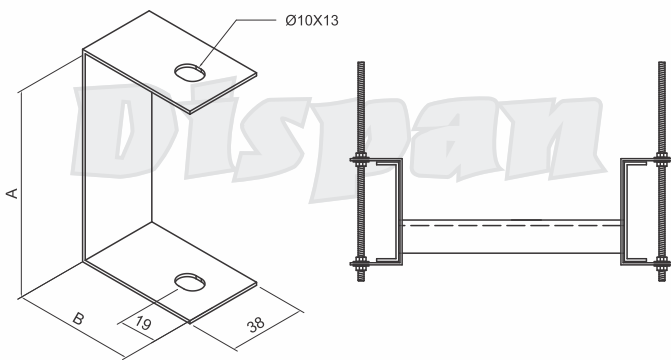

Cinta para fechamento de tampa para leito - DP859C

Support and belt for cable tray ladder type.

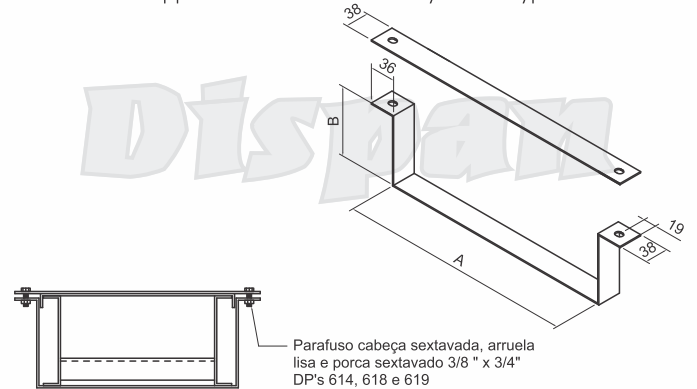

Esquema de montagem da cinta p/ fechamento de tampa.

Typical applications.

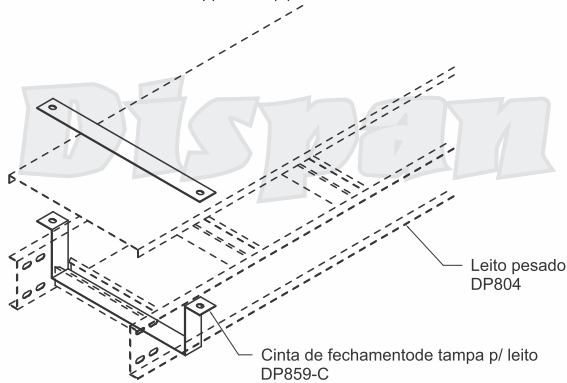

Parafuso cabeça lentilha c/ fenda - DP612

"Lentil" - type head screw.

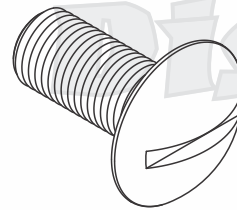

Rosca	Comprimento
1/4"	1/2"
1/4"	5/8"
1/4"	3/4"
5/16"	3/4"
3/8"	3/4"

Parafuso cabeça lentilha auto - travante - DP613

"Lentil" - type head screw.

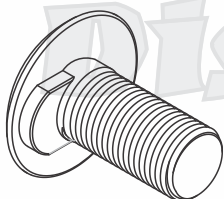

Rosca	Comprimento
1/4"	1/2"
1/4"	5/8"
1/4"	3/4"
5/16"	3/4"
3/8"	3/4"

Parafuso cabeça sextavada - DP614

Hex screw.

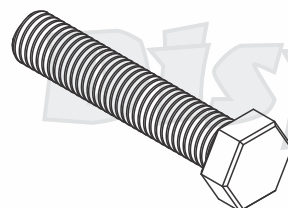

Rosca	Comprimento
	1/2"
	3/4"
1/4"	1"
5/16"	1.1/2"
3/8"	2"
	2.1/2"
	3"

Porca sextavada - DP618

Hex nut.

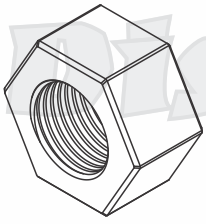

Rosca
1/4"
5/16"
3/8"
1/2"

Arruela lisa - DP619

Plain washer



Rosca
1/4"
5/16"
3/8"
1/2"

Porca losangular s/ mola - DP621

Lozenge nut.

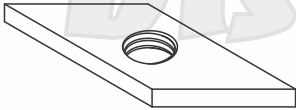

Rosca	Carga máx. em Kg.
1/4"	120 Kg
5/16"	210 Kg
3/8"	450 Kg
1/2"	500 Kg

Porca losangular c/ mola - DP622

Lozenge nut with spring.

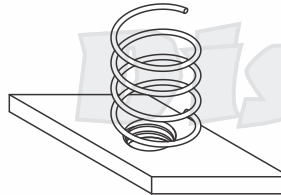

Rosca	Carga máx. em Kg.
1/4"	120 Kg
5/16"	210 Kg
3/8"	450 Kg
1/2"	500 Kg

Vergalhão rosca total - DP608

Continuos threaded rod.



Tabela de carga.	
Diametros do vergalhão	Carga máxima
Vergalhão 1/4"	Kg <u>450</u>
Vergalhão 5/16"	Kg <u>600</u>
Vergalhão 3/8"	Kg <u>920</u>
Vergalhão 1/2"	Kg <u>1250</u>

Prolongador p/ vergalhão - DP610

Hanger rod extension.

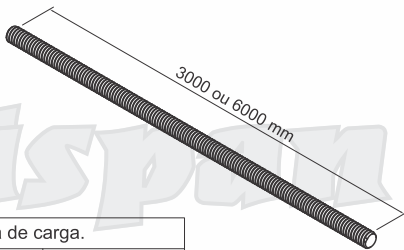

Tabela de carga.	
Diametros do prolongador	Carga máxima
Prolongador 1/4"	Kg <u>450</u>
Prolongador 5/16"	Kg <u>600</u>
Prolongador 3/8"	Kg <u>920</u>
Prolongador 1/2"	Kg <u>1250</u>

Fixação de leito com grapa fixa 3/8" aba interna.

Typical applications of the single beam clamp.

Parafuso cabeça sextavada, grapa fixa, arruela lisa e porca sextavada 3/8" x 1 1/2"
DP's 611, 614, 618 e 619

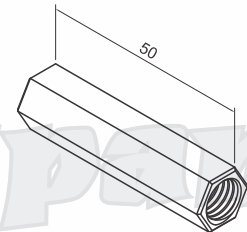
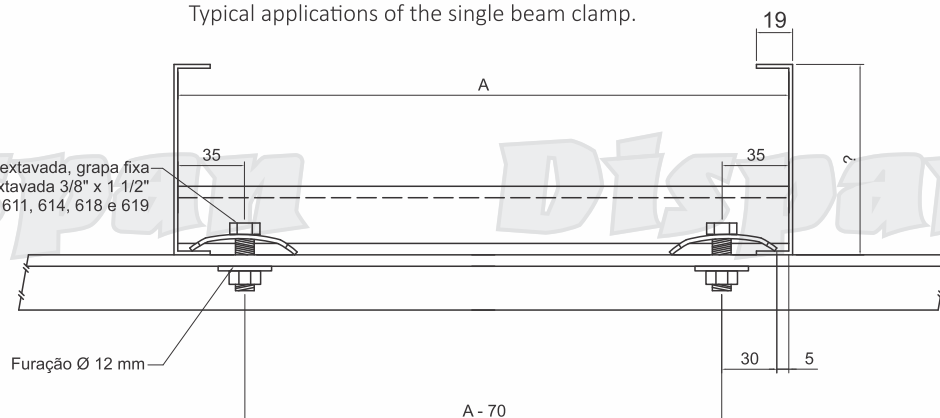

Fixação de leito com grapa fixa 3/8" aba externa.

Typical applications of the single beam clamp

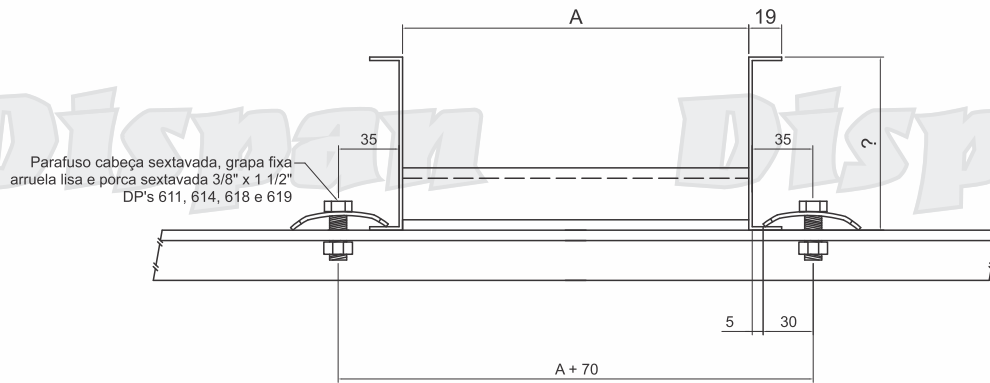

Grapa fixa 3/8" - DP611

Single beam clamp

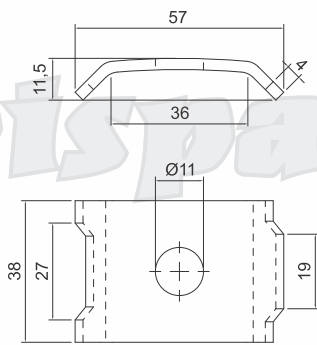

Mata junta para leito - DP859

Closing to anglo cover.

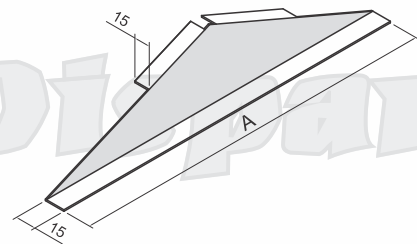

Obs.: As mata juntas são necessárias, todas as vezes que houver um encontro de conexões e trechos reto de leito utilizando tampa 2 águas.

Esquema de montagem para mata junta para leito.

Typical applications of the closing to anglo cover.

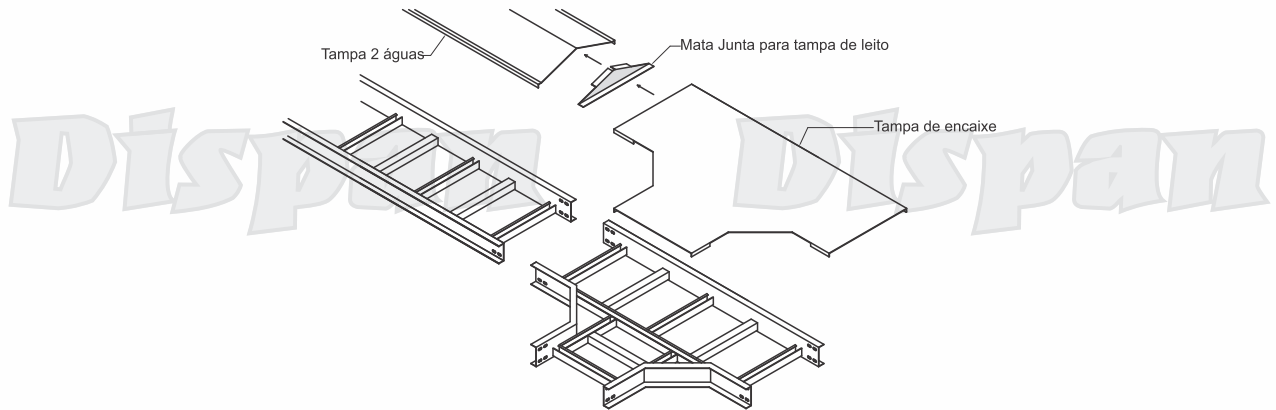

Suporte de fixação para leito - DP858

Side fastening support.

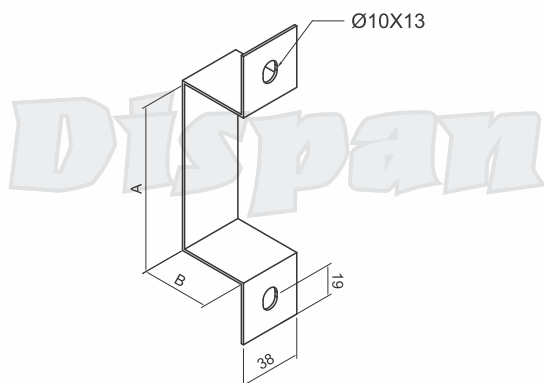

Gotejador para leito - DP861

Cable drop out.

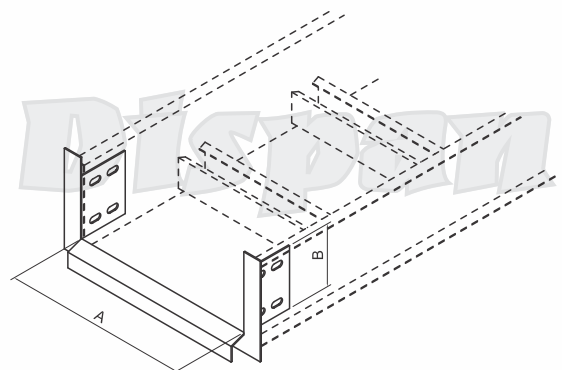

Indicar cota A e B.

Junção horizontal articulada para leito - DP860

Horizontal articulated junction.

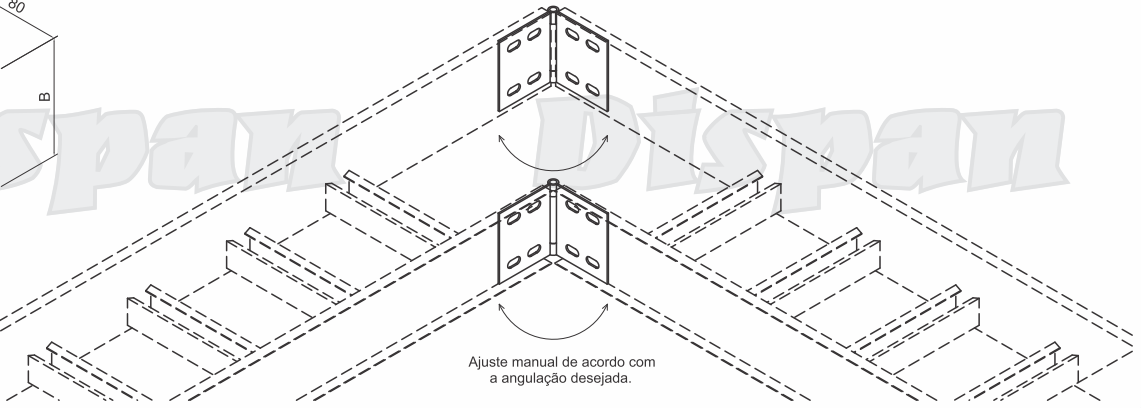
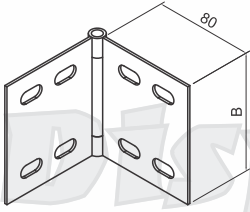

Indicar cota B.

Ajuste manual de acordo com a angulação desejada.

Junção vertical 45° para leito - DP862

Vertical junction 45°

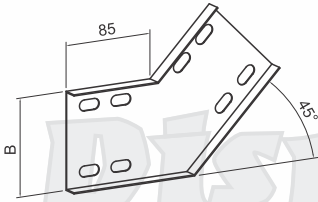

Carga uniformemente distribuída em mão francesa.

Uniformly distributed loads on bracket.

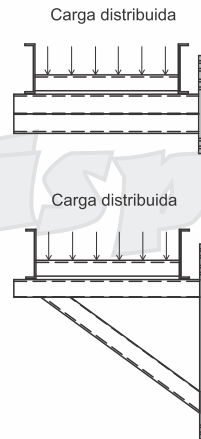
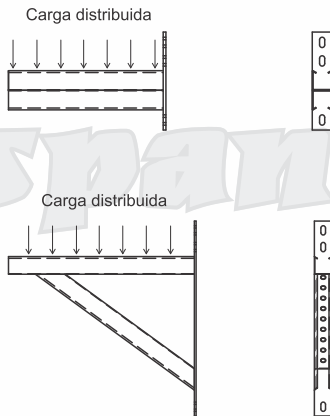

Mão francesa dupla - DP747

Double bracket.

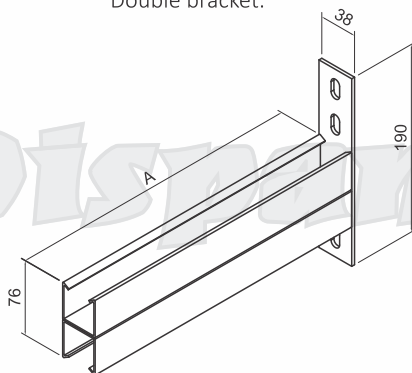

Indicar cota A.

Mão francesa reforçada - 748

Reinforced bracket.

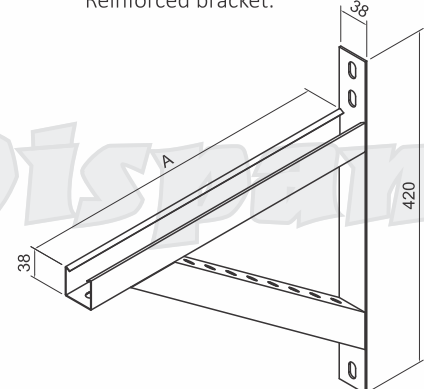

Indicar cota A

Eletrocalhas

Cable trays

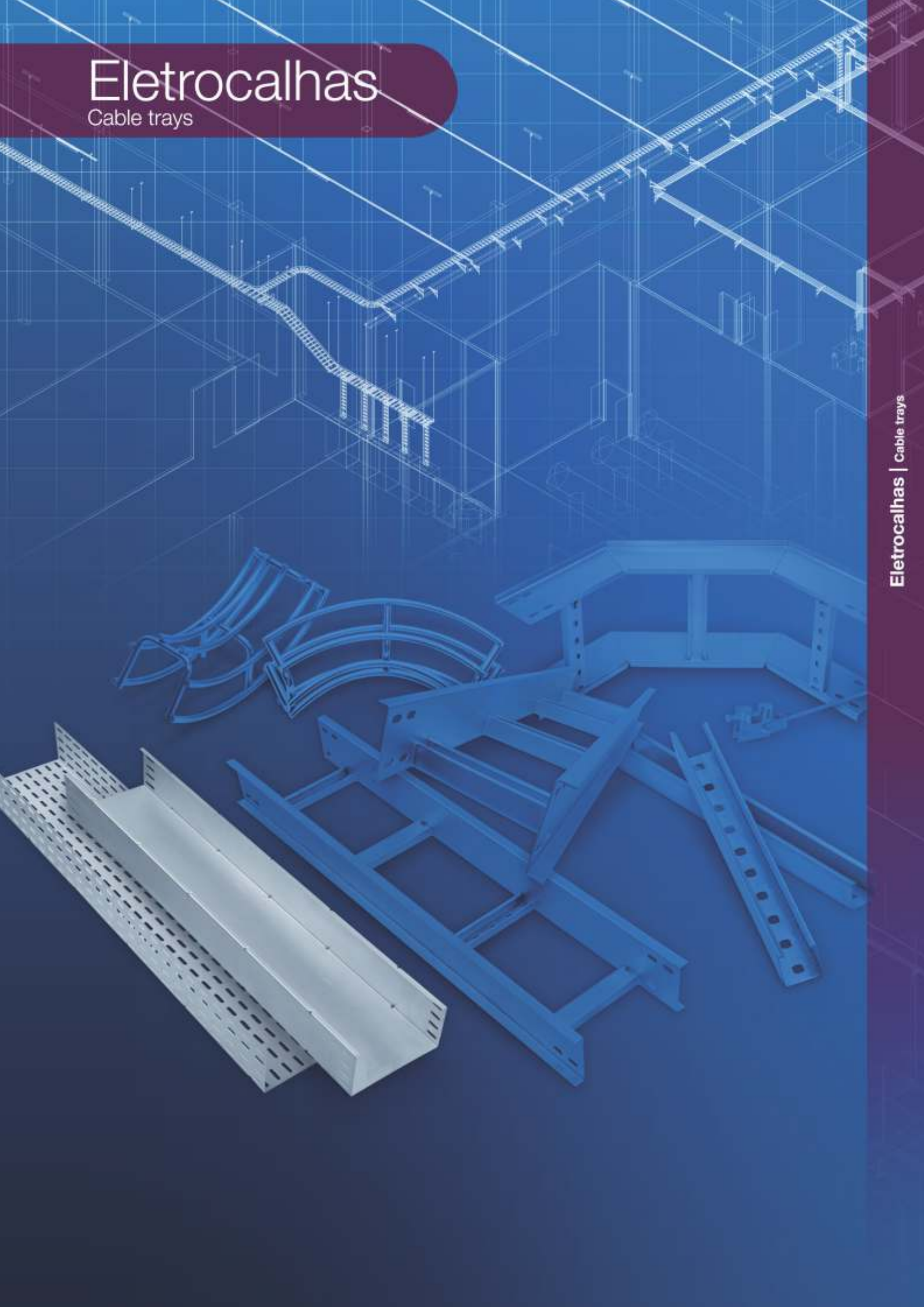

ELETROCALHAS		ELETROCALHAS		ELETROCALHAS	
Código dos Materiais	Ver Página	Código dos Materiais	Ver Página	Código dos Materiais	Ver Página
DP608	39	DP718C	46	DP753	49
DP612	39	DP719	43	DP755	49
DP613	39	DP719C	46	DP757	49
DP618	39	DP720	43	DP758	49
DP619	39	DP720C	46	DP760	41
DP700	37	DP721	43	DP761	45
DP701	37	DP721C	46	DP762	50
DP701E	37	DP722	43	DP763-C	50
DP702	37	DP723	43	DP764	51
DP703	37	DP724	43	DP765	49
DP703E	37	DP725	43	DP766	50
DP704	37	DP725C	46	DP770	41
DP705	37	DP726	44	DP771	41
DP706	38	DP727	44	DP772	41
DP706-AP	38	DP728	44	DP775	51
DP706-AP2A	38	DP729	44	DP776	51
DP706-FR	38	DP730	44	DP859E	50
DP706-2A	38	DP731	44		
DP707	38	DP732	44		
DP707-2A	38	DP733	45		
DP708	39	DP734	47		
DP709	39	DP736	47		
DP710	42	DP737	47		
DP710C	45	DP738	47		
DP711	42	DP739	44		
DP711C	45	DP739C	46		
DP712	42	DP740	47		
DP712C	45	DP741	47		
DP713	42	DP742	47		
DP713C	45	DP743	47		
DP714	42	DP744	48		
DP714C	45	DP745	48		
DP715	42	DP746	48		
DP715C	45	DP747	48		
DP716	42	DP748	48		
DP716C	46	DP749	48		
DP717	42	DP750	49		
DP717C	46	DP751	49		
DP718	43	DP752	49		

Anotações

Dispan

Como solicitar eletrocalhas

How to specify cable tray channel type.

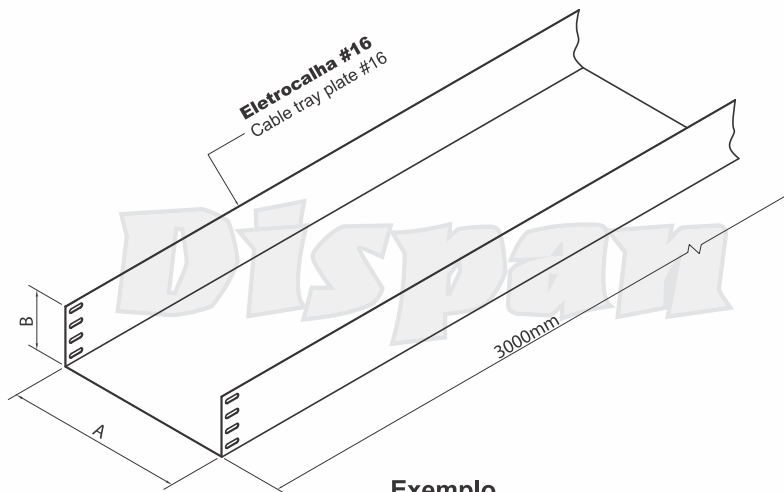

Exemplo
Example

DP700 - AC - GF - 400/100 - 16

Referência do catálogo de produtos com características básicas

Product catalog reference with basic features

Matéria-prima de fabricação

Manufacturing raw material

Acabamento

Finish

Largura / Altura da eletrocalha

Width / height of cable tray

Chapas de construção da eletrocalha

Cable tray construction plate

DP 700 • Eletrocalha lisa sem virola
DP 700 • Flat cable tray without ferrule

Matéria-prima base
Raw material base

AC - Aço carbono
Carbon Steel

AI - Aço inox
Stainless Steel

AL - Alumínio
Aluminum

Acabamento aplicado na matéria-prima em base de aço carbono

Finish applied to the raw material in carbon steel base

GF - Galvanizado à fogo por imersão
Hot dip galvanized

GE - Galvanizado eletrolítico
Electrolytic galvanized

PZ - Pré-zincado
Pre-zincated

NT - Natural
Natural

PT - Pintado
Painting

Largura:
400 - Largura da eletrocalha desejada
(De 100 a 1500 mm).

Width: 400 - width of the wanted cable tray (100 to 1500mm)

Espessuras de chapas:
16 - Chapa de eletrocalha
Plate thickness: 16 - cable tray plate

* Chapas disponíveis = #12 / #14 / #16 / #18 / #20 / #22 / #24.

Descritivo técnico | Technical description

DP 700 • Eletrocalha lisa sem virola, em aço carbono, galvanizado à fogo, largura de 400mm, com aba de 100mm em chapa #16.
DP 700 • Flat single cable tray, carbon steel, hot dip galvanized, width of 400mm, with tab of 100mm in plate #16.

ATENÇÃO!

A DISPAN INDÚSTRIA E COMÉRCIO não recomenda o uso de leito ou eletrocalha como passarela, escada ou apoio para pessoas.
USE APENAS PARA PASSAGEM DE CABOS.

UTILIZE OS EPI'S CONFORME NR-06 E SIGA AS PRÁTICAS DE SEGURANÇA NO TRABALHO, COMO DESCRITO NA NR-10 E NR-35.



Nota

Ocasionalmente podem ocorrer algumas distorções de medidas em nossas peças, por diversos fatores. Por este motivo damos uma tolerância de 5,0 mm entre as medidas mencionadas no catálogo e as peças reais. Os furos oblongos são feitos exatamente para compensação e ajuste de eventuais diferenças.

WARNING!

DISPAN Industry and Trade does not recommend using cable trays or bed ladder as walkway, stair or support for people.
USE ONLY FOR PASSING OF CABLES.

USE THE PPI'S AS THE NR-06 AND FOLLOW THE WORK SAFETY PRACTICES AS DESCRIBED IN NR-10 AND NR-35.

Note

Occasionally, it may occur some distortion of measures in our pieces, for several reasons. Because of this, we give a toleration of 5.0 mm between the measures mentioned in this catalog and the real pieces. The slotted holes are made just for clearing and settling of any possible differences.

Como solicitar conexões para eletrocalhas

How to specify connections for cable tray channel type.

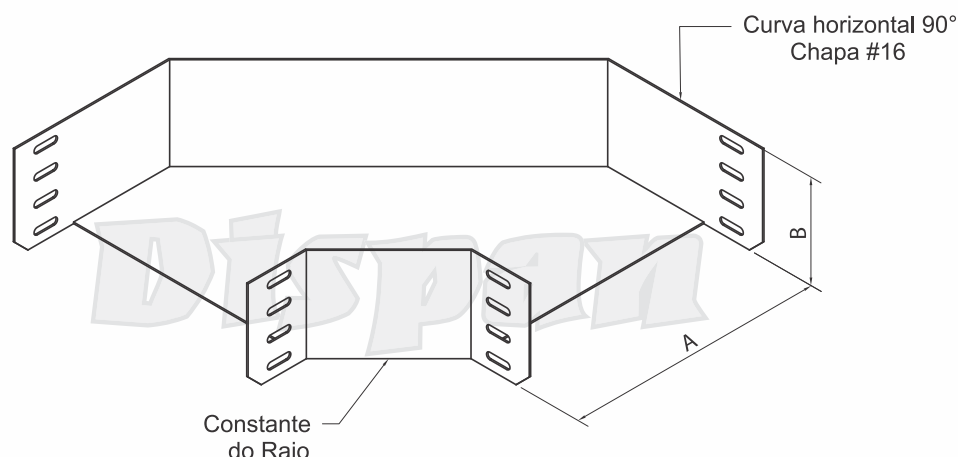

Exemplo
Example

DP 710 / 700 - AC - GF - 400/100 - 16 - R150

Raio 150, 200
300, 500
Radius 150, 200
300, 500

Referência do catálogo de produtos com características básicas

Product catalog reference with basic features

Modelo da eletrocalha

Cable tray model

Matéria-prima de fabricação

Manufacturing raw material

Acabamento

Finish

Largura / Altura da eletrocalha

Width / height of cable tray

Chapas de construção da eletrocalha

Cable tray construction plate

DP 710 • Curva horizontal 90°
DP 700 • Horizontal bend 90°

Matéria-prima base

Raw material base

AC - Aço carbono
Carbon Steel

AI - Aço inox
Stainless Steel

AL - Alumínio
Aluminum

Acabamento aplicado na matéria-prima em base de aço carbono

Finish applied to the raw material in carbon steel base

GF - Galvanizado à fogo por imersão
Hot dip galvanized

GE - Galvanizado eletrolítico
Electrolytic galvanized

PZ - Pré-zincado
Pre-zincated

NT - Natural
Natural

PT - Pintado
Painting

Largura:
400 - Largura da eletrocalha desejada (De 100 a 1500 mm).

Width: 400 - width of the wanted cable tray (100 to 1500mm)

Espessuras de chapas:
16 - Chapa de eletrocalha
Plate thickness: 16 - cable tray plate

* Para solicitação da tampa, colocar o código + a letra "T": Exemplo = DP710T

Descritivo técnico | Technical description

DP 710 • Curva horizontal 90° para eletrocalha DP 700, em aço carbono, galvanizado à fogo, largura de 400 mm, com aba de 100 mm em chapa #16, raio de 150 mm, segmentada.

DP 710 • Horizontal bend 90° for cable tray DP700, carbon steel, hot dip galvanized, width of 400mm, with tab of 100mm in plate #16, radius of 150mm, segmented.

Nota - 1

Ocasionalmente podem ocorrer algumas distorções de medidas em nossas peças, por diversos fatores. Por este motivo damos uma tolerância de 5,0 mm entre as medidas mencionadas no catálogo e as peças reais. Os furos oblongos são feitos exatamente para compensação e ajuste de eventuais diferenças.

Note - 1

Occasionally, it may occur some distortion of measures in our pieces, for several reasons. Because of this, we give a toleration of 5.0 mm between the measures mentioned in.

Nota - 2

As conexões para eletrocalhas, tem como padrão virola de 10 mm, caso haja a necessidade fabricamos com virola de 25 mm, sob consulta.

Note - 2

The connections for cable tray have a standard ferrule of 10mm. In necessary case, we could manufacture ferrule with 25mm, under evaluation.

Nota - 3

Em caso de necessidade podemos fabricar as conexões de eletrocalhas no padrão antigo, sob consulta.

Note - 3

In necessary case, we could manufacture cable tray connections in old standard, under evaluation.

Exemplo de montagem para eletrocalha

Typical applications

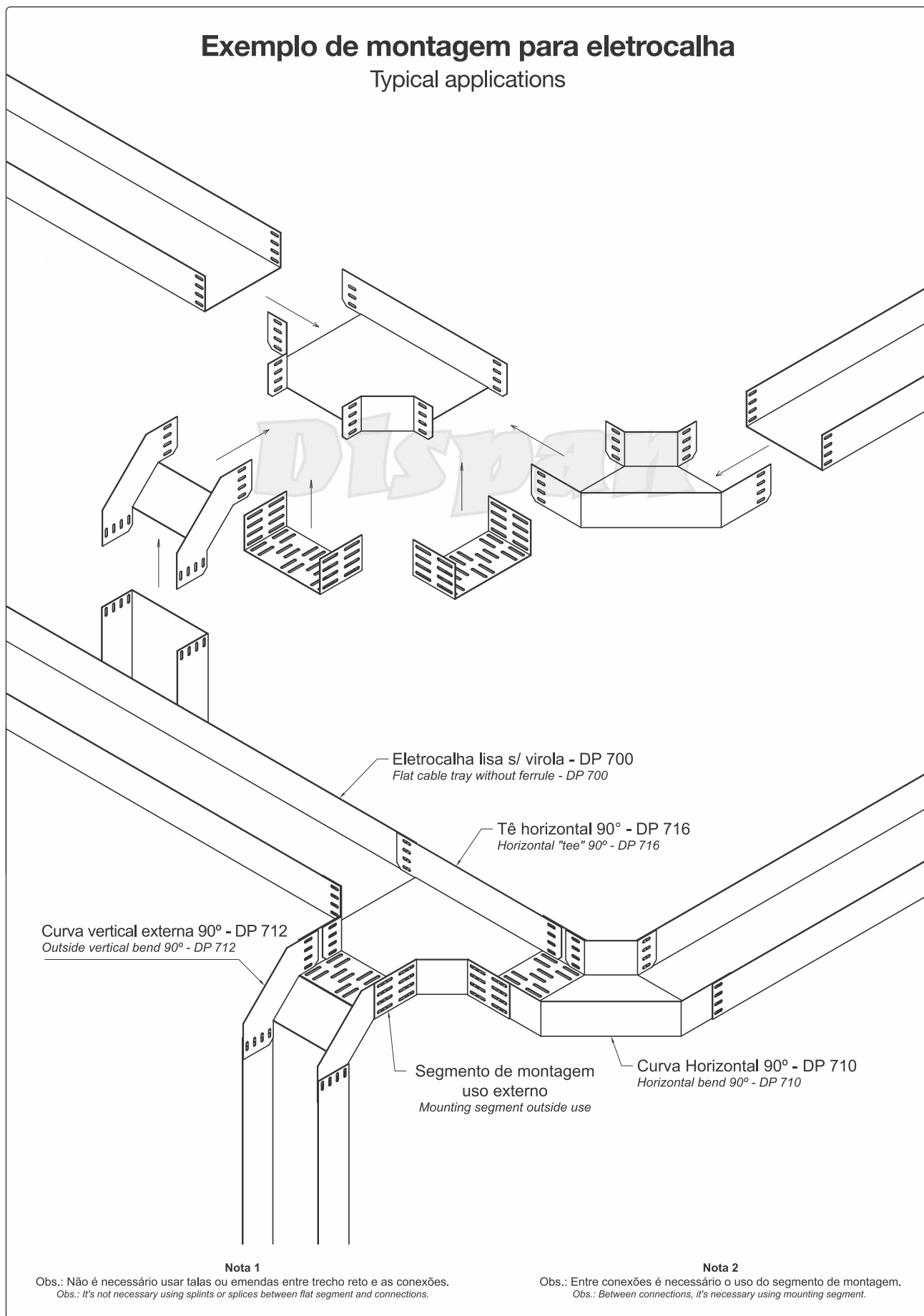

Eletrocalha lisa s/ virola - DP700

Cable tray single- U.

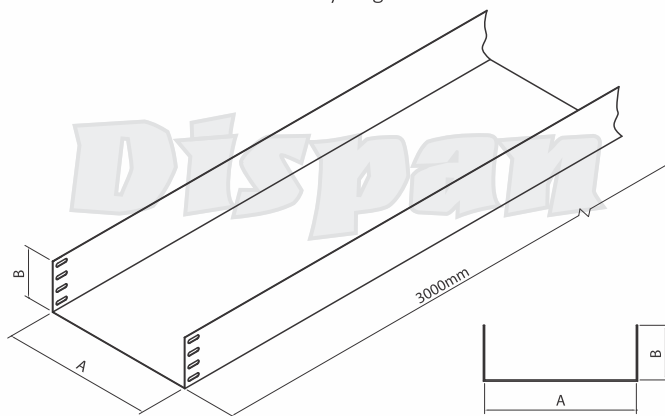

Eletrocalha lisa c/ virola - DP701

Cable tray single- C

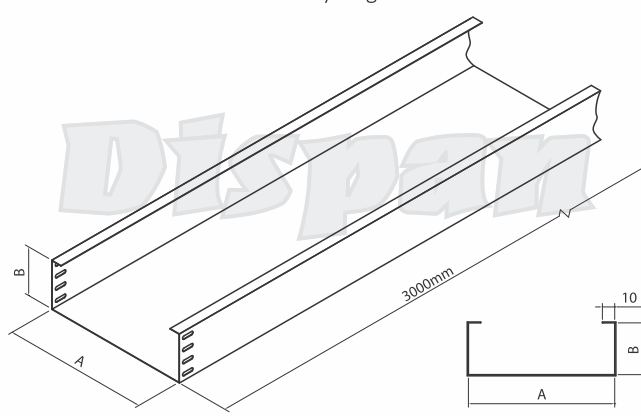

Eletrocalha perfurada s/ virola - DP702

Cable tray perforated- U.

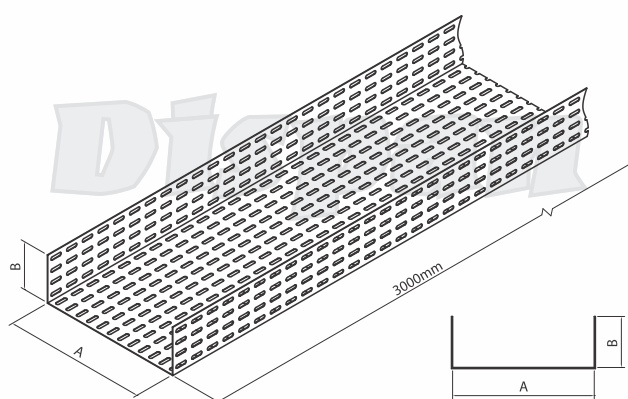

Eletrocalha perfurada c/ virola - DP703

Cable tray perforated- C.

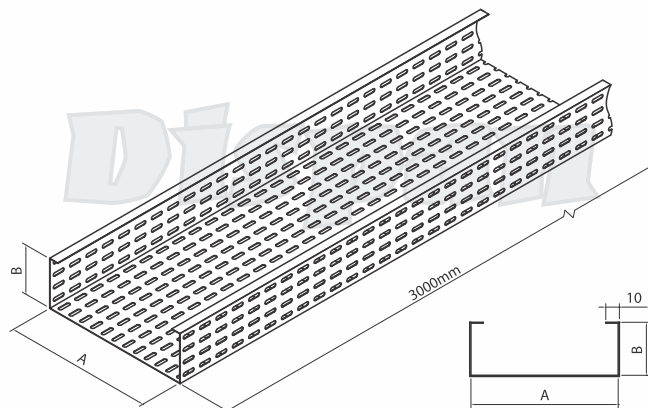

Eletrocalha lisa s/ virola com divisor - DP704

Cable tray single- U with divider.

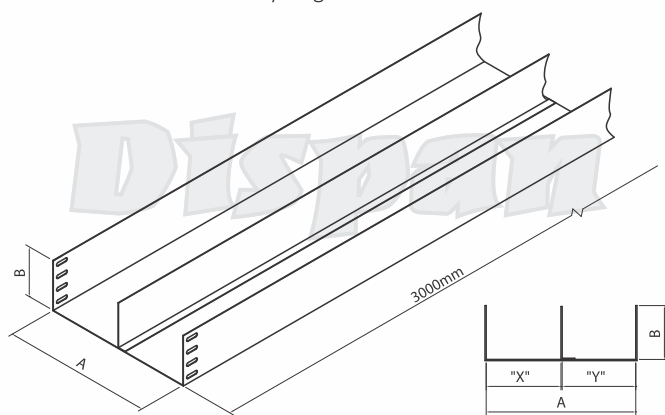

Eletrocalha lisa c/ virola e divisor - DP705

Cable tray single- C with divider.

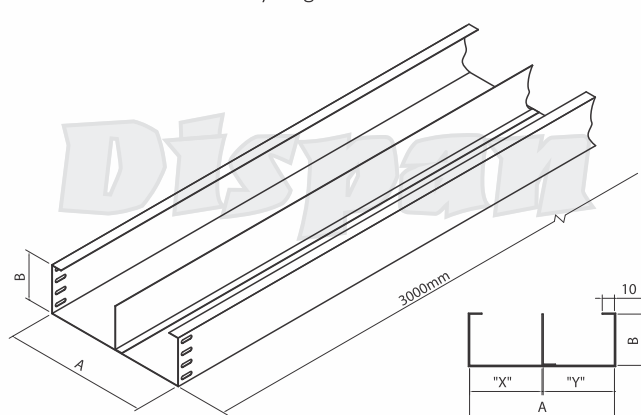

Eletrocalha lisa estrutural c/ virola 180° - DP701E

Strutural flat cable tray with ferrule 180°

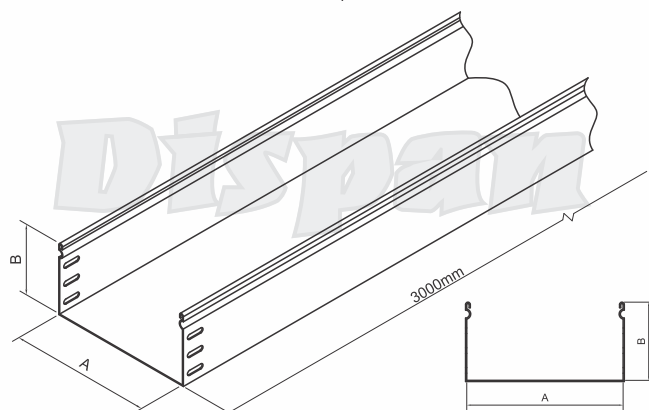

Eletrocalha perfurada estrutural c/ virola 180° - DP703E

Perforated strutural cable tray with ferrule 180°

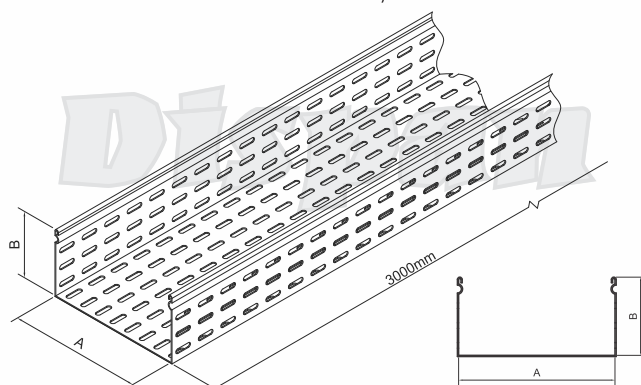

Tampa de encaixe - DP706

Insert cover.

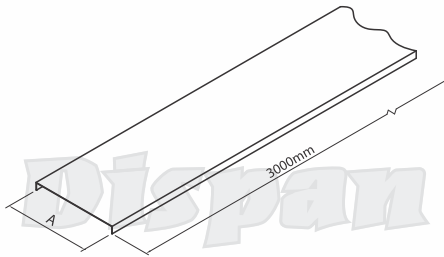

Tampa de pressão - DP707

Pressure cover.

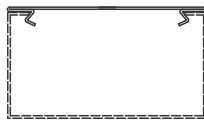
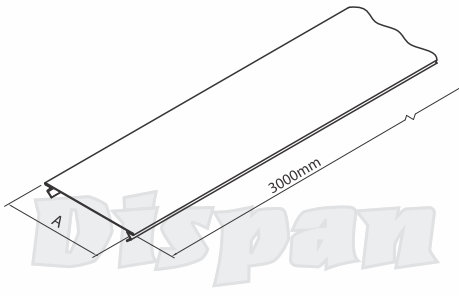

Obs.: Para conexões, consultar tampas aparafusadas.

Tampa 2 águas de encaixe - DP706-2A

Angular cover.

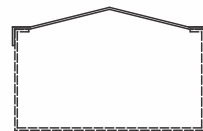
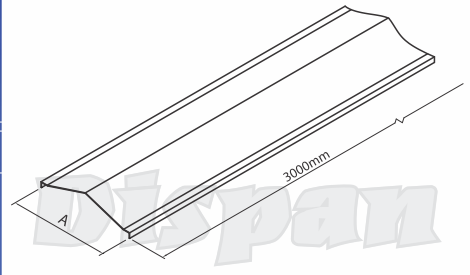

Obs.: Não fabricamos tampa 2 águas para conexões, vide DP859.

Tampa 2 águas de pressão - DP707-2A

Pressure angular cover.

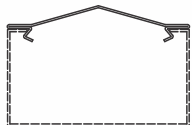
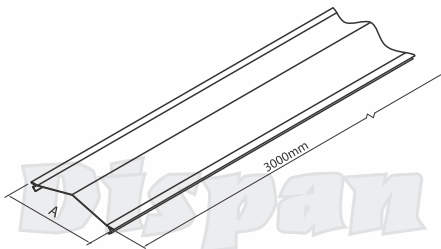

Obs.: Não fabricamos tampa 2 águas para conexões, vide DP859E.

Tampa p/ eletrocalha estrutural c/ virola 180° DP706-E

Structural cable pressure cover.

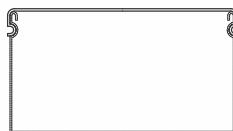
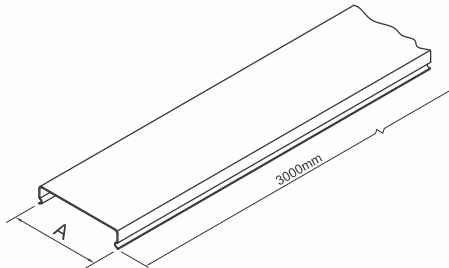

Tampa fecho rápido - DP706-FR

Inserte cover with fast lock.

* Somente para eletrocalha com virola

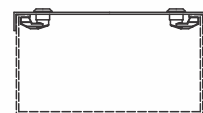
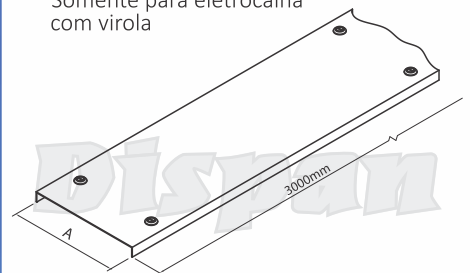

Tampa de encaixe aparafusada - DP706-AP

Insert cover to screw.

* Somente para eletrocalha com virola

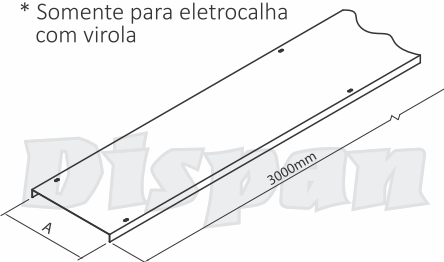

Obs.: Para a fixação, acompanham parafusos brocante Ø 4,2 x 13 mm.

Tampa de encaixe 2 águas aparafusada - DP706-AP2A

Angular cover to screw.

* Somente para eletrocalha com virola

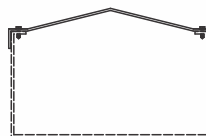
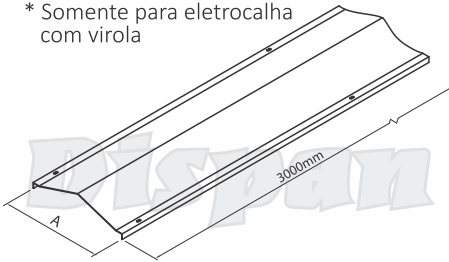

Obs.: Não fabricamos tampa 2 águas para conexões, vide DP859.

Esquema de montagem da tampa de 2 águas encaixe c/ presilha.

Typical applications to angular cover with beam clamp.

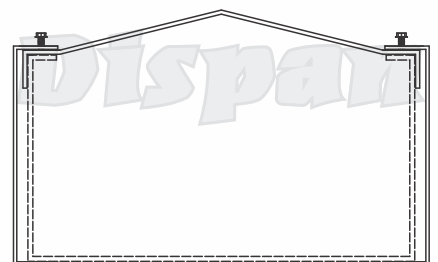

Esquema de montagem da tampa de encaixe c/ presilha.

Typical applications to insert cover with beam clamp.

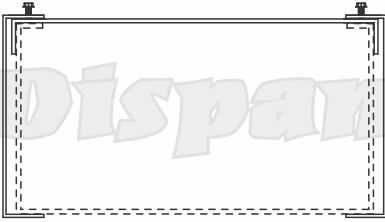

Esquema de montagem da tampa de encaixe c/ cinta p/ fechamento.

Typical applications to angular cover with belt.

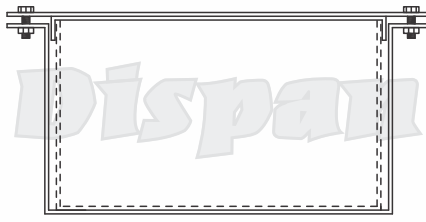

Septo divisor perfurado - DP708

Perforated divider.

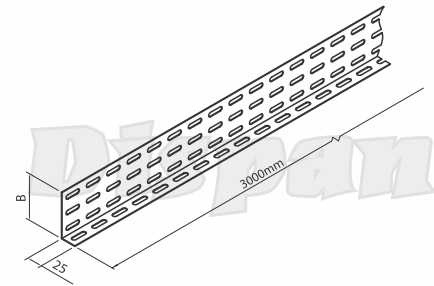

Obs.: Septo de 3000 mm apenas para o uso da tala, para o uso da emenda interna o septo de 2850mm.

Septo divisor liso - DP709

Single divider.

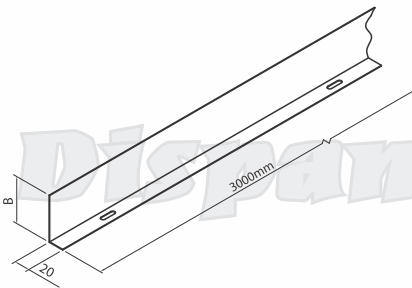

Obs.: Septo de 3000 mm apenas para o uso da tala, para o uso da emenda interna o septo de 2850mm.

Parafuso cabeça lentilha c/ fenda - DP612

Lentil head bolt.

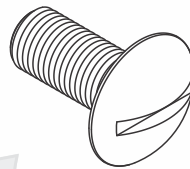

Rosca	Comprimento
1/4"	1/2"
1/4"	5/8"
1/4"	3/4"
5/16"	3/4"
3/8"	3/4"

Parafuso cabeça lentilha auto-travante - DP613

Lentil head self lock bolt.

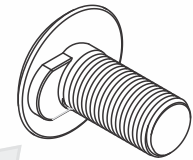

Rosca	Comprimento
1/4"	1/2"
1/4"	5/8"
1/4"	3/4"
5/16"	3/4"
3/8"	3/4"

Porca sextavada - DP618

Hex nut.

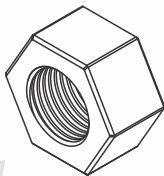

Rosca
1/4"
5/16"
3/8"
1/2"

Arruela lisa - DP619

Lock washer.

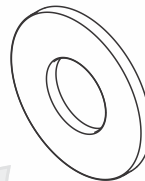

Rosca
1/4"
5/16"
3/8"
1/2"

Vergalhão rosca total - DP608

Threaded rod.



Tabela de carga.	
Diametros do vergalhão	Carga máxima
Vergalhão 1/4"	Kg <u>450</u>
Vergalhão 5/16"	Kg <u>600</u>
Vergalhão 3/8"	Kg <u>920</u>
Vergalhão 1/2"	Kg <u>1250</u>

Montagem de mata junta interna p/ eletrocalhas.

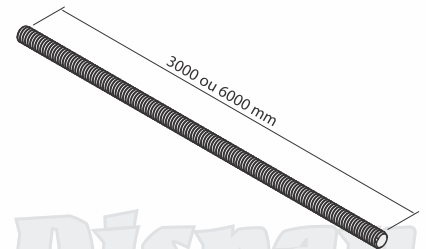
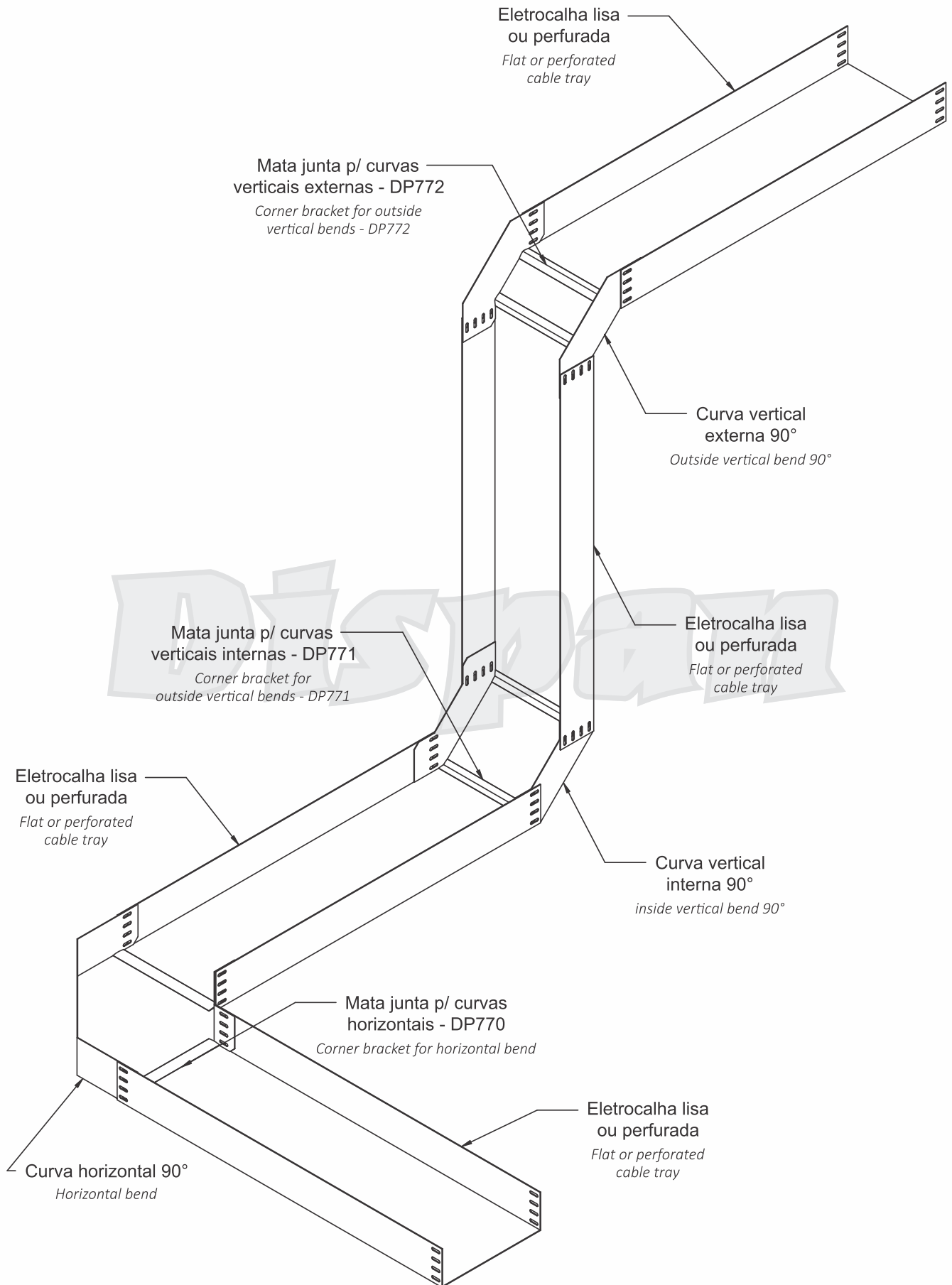

Segmento de montagem - DP760

Coupling enter Connections.

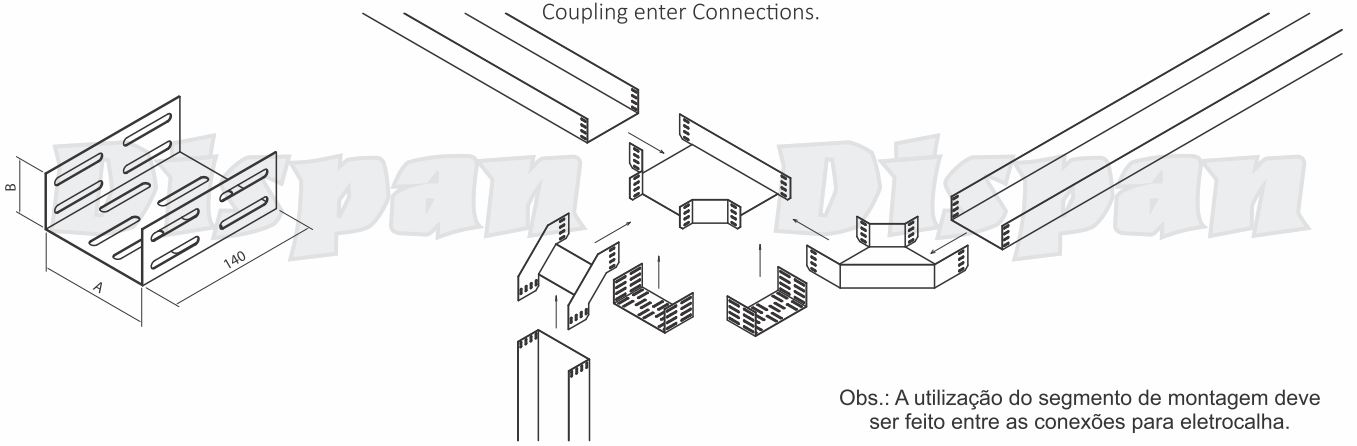

Obs.: A utilização do segmento de montagem deve ser feito entre as conexões para eletrocalha.

Mata junta interna p/ curvas horizontais - DP770

Internal corner bracket for horizontal bends

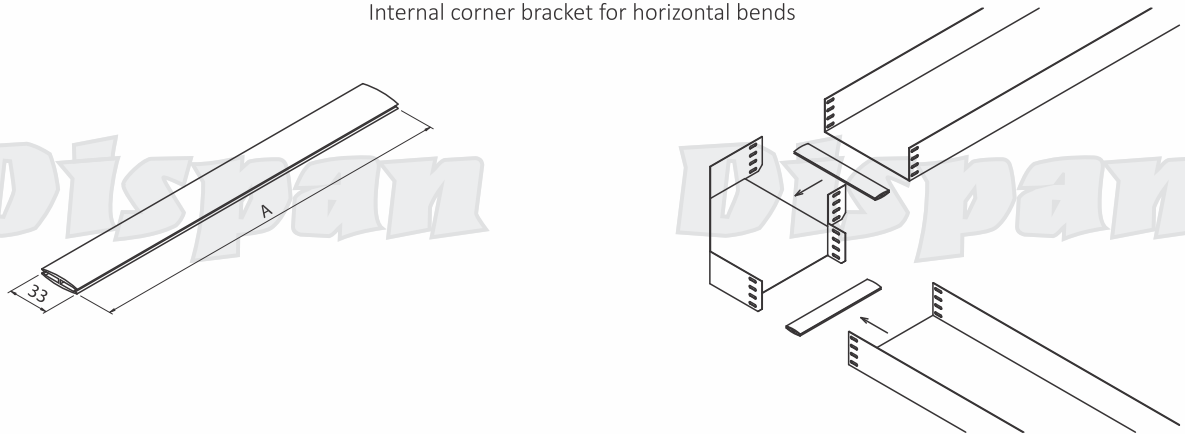

Mata junta interna p/ curvas verticais internas - DP771

Internal corner bracket for inside vertical bends

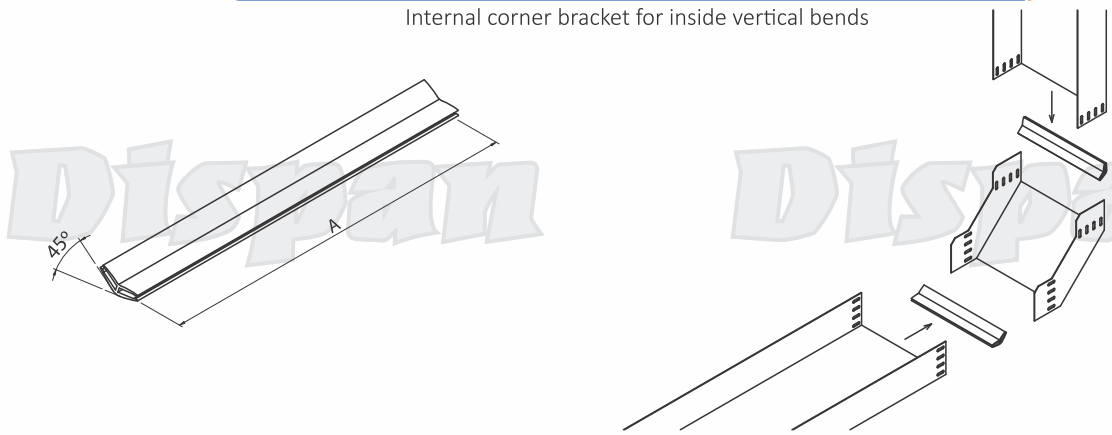

Mata junta interna p/ curvas verticais externas - DP772

Internal corner bracket for out side vertical bends

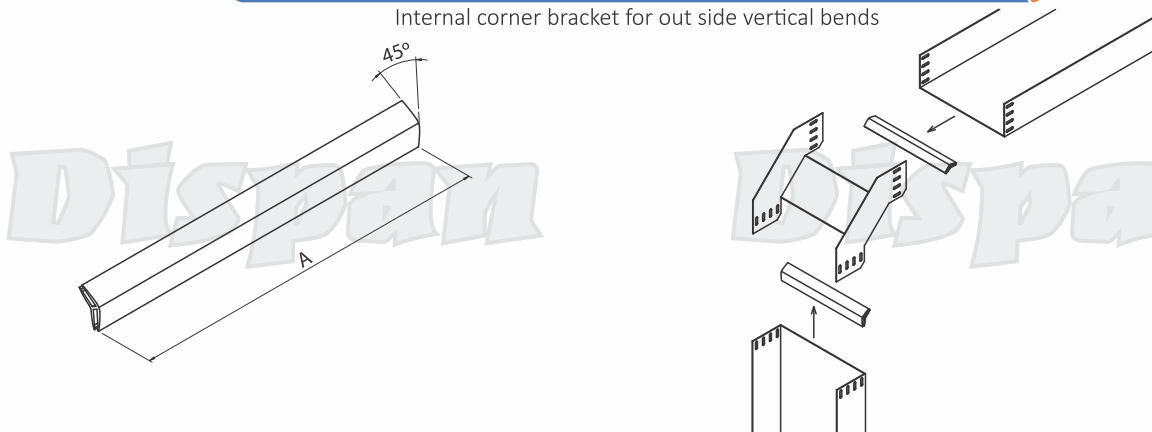

**Conexões
com raio
segmentado**

Curva horizontal 90° - DP710

Horizontal bend 90°

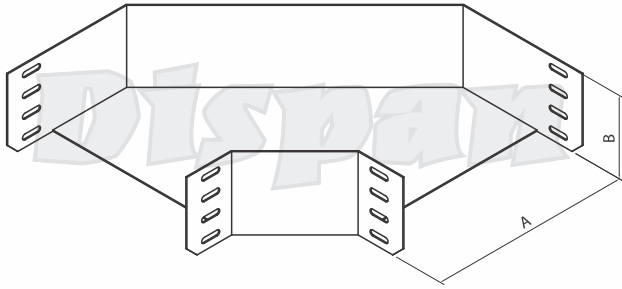

Indicar Cota A e B

Curva horizontal 45° - DP711

Horizontal bend 45°

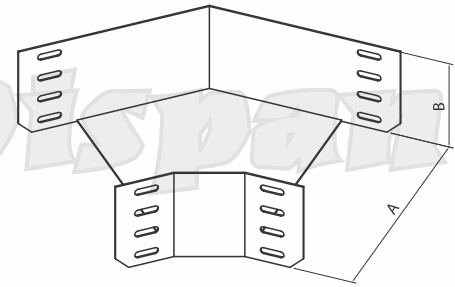

Indicar Cota A e B

Curva vertical externa 90° - DP712

External vertical bend 90°

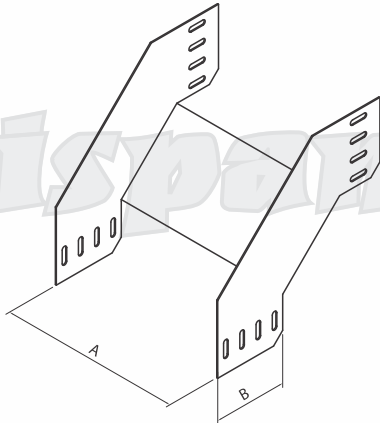

Indicar Cota A e B

Curva vertical externa 45° - DP713

External vertical bend 45°

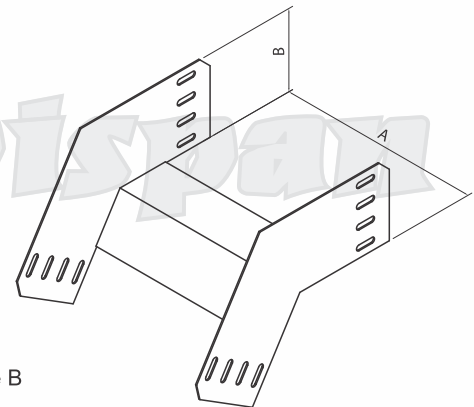

Indicar Cota A e B

Curva vertical interna 90° - DP714

Internal vertical bend 90°

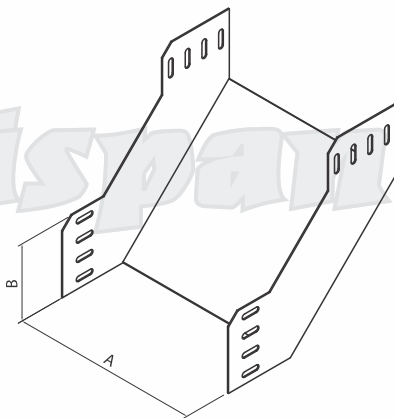

Indicar Cota A e B

Curva vertical interna 45° - DP715

Internal vertical bend 45°

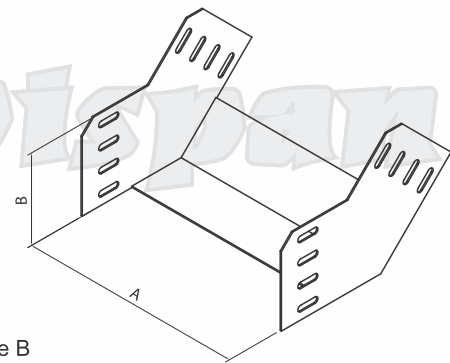

Indicar Cota A e B

Tê horizontal 90° - DP716

Horizontal tee 90°

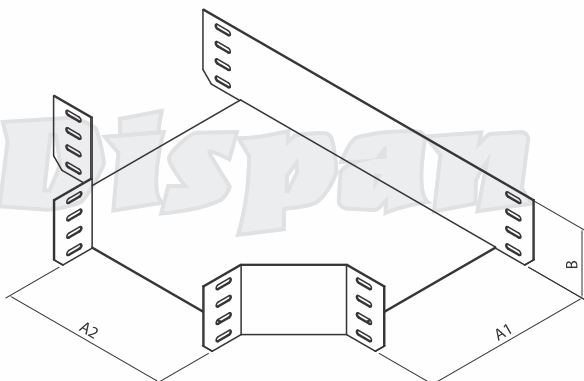

Indicar Cota A e B

Tê vertical de descida 90° - DP717

Vertical descent tee 90°

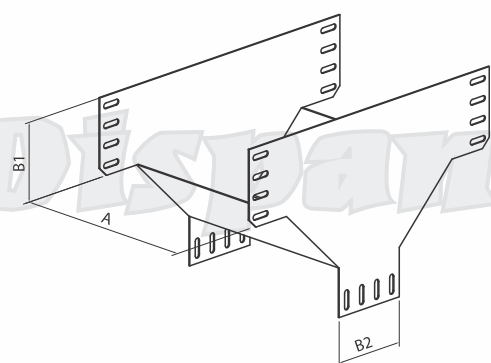

Indicar Cota A e B

Tê vertical de subida 90° - DP718

Vertical ascent tee 90°

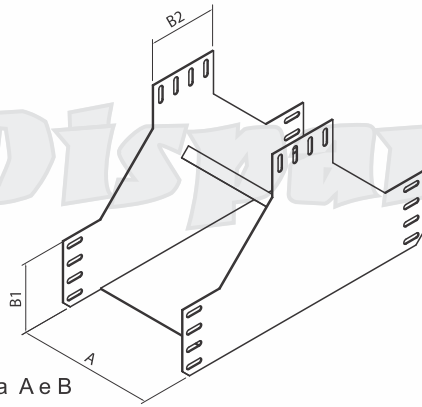

Indicar Cota A e B

Tê vertical de descida lateral 90° raio DP719

Lateral descent tee 90°

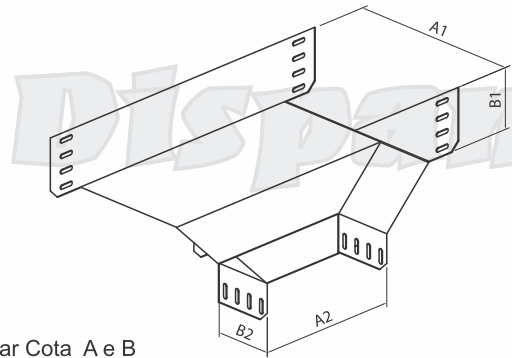

Indicar Cota A e B

Cruzeta horizontal 90° - DP720

Horizontal cross 90°

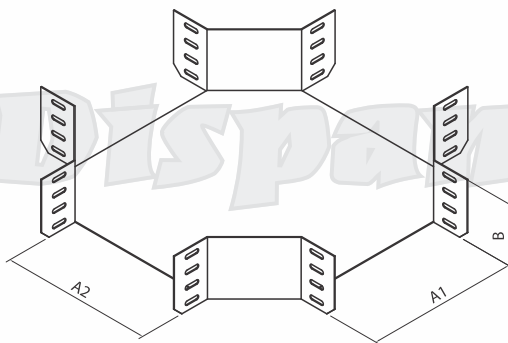

Indicar Cota A e B

Curva de inversão 90° - DP721

Inversion bend 90°

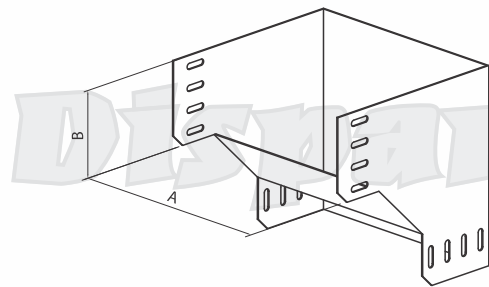

Indicar Cota A e B

Tê reto 90° - DP722

Straight tee.

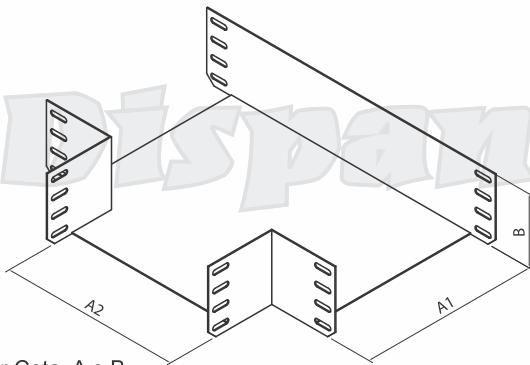

Indicar Cota A e B

Cotovelo reto 90° - DP723

Elbow 90°

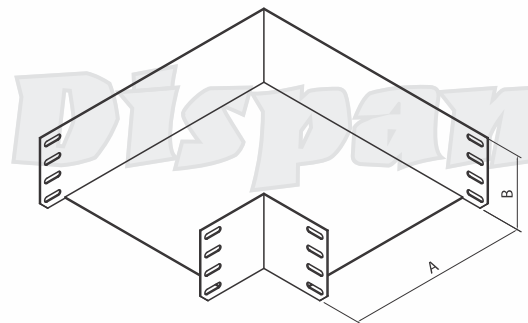

Indicar Cota A e B

Cruzeta reta 90° - DP724

Straight cross.

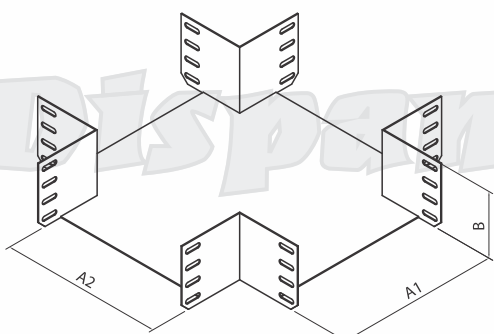

Indicar Cota A e B

Curva com passagem reta subida 90° DP725

90° Bend with ascent straight passage.

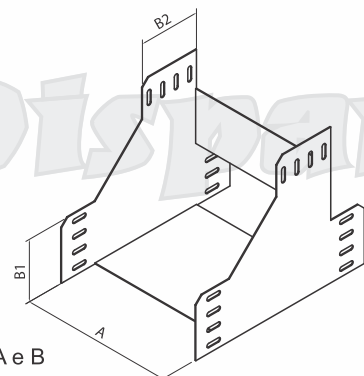

Indicar Cota A e B

Junção à direita 45° - DP726

Right junction.

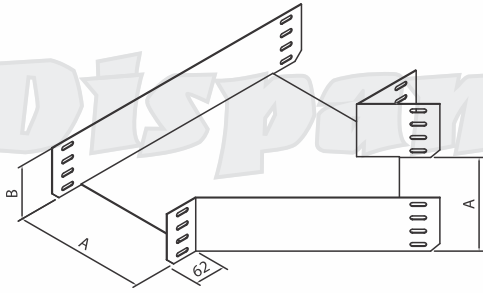

Indicar Cota A e B

Junção à esquerda 45° - DP727

Left junction.

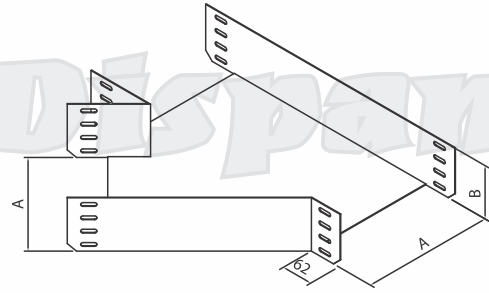

Indicar Cota A e B

Curva com passagem reta descida 90° raio segmentado - DP739

Bend with descent straight passage.

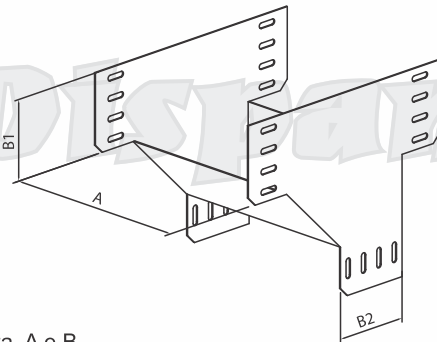

Indicar Cota A e B

Desvio horizontal à esquerda 45° - DP728

Left deviation.

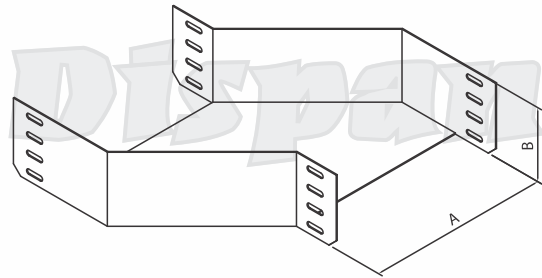

Indicar Cota A e B

Desvio horizontal à direita 45° - DP729

Right deviation.

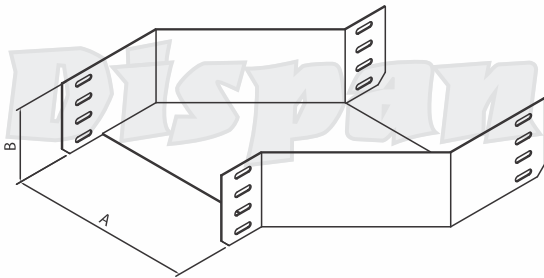

Indicar Cota A e B

Redução concêntrica - DP730

Concentric reduction.

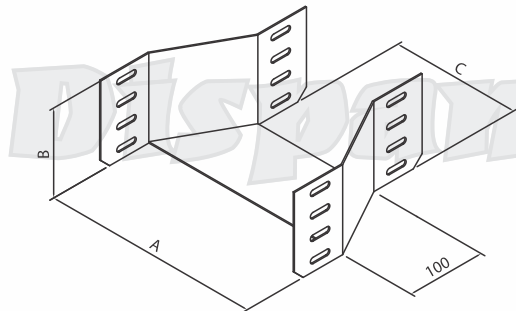

Indicar Cota A e B

Redução à direita - DP731

Right reduction.

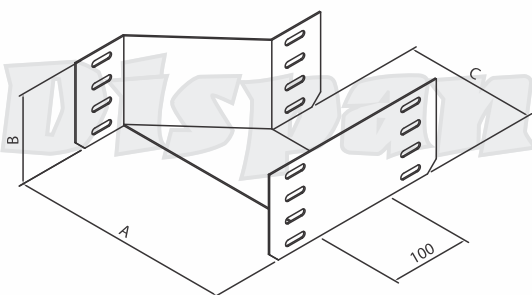

Indicar Cota A e B

Redução à esquerda - DP732

Left reduction.

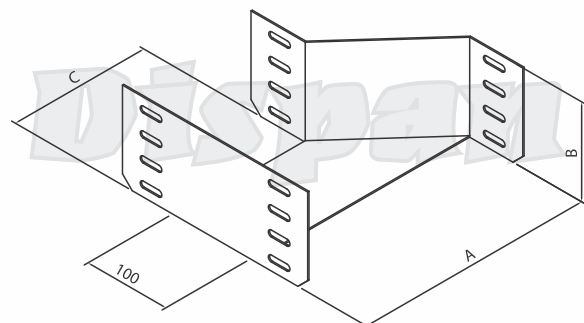

Indicar Cota A e B

Redução de abas - DP733

Beam reduction.

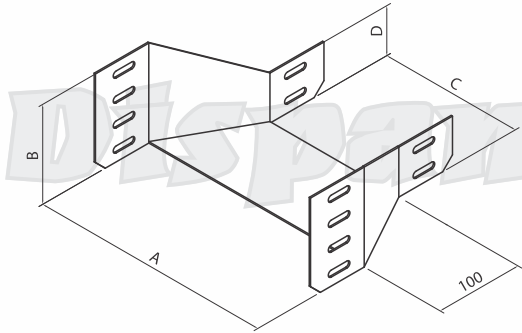

Indicar Cota A e B

Presilha para tampa em eletrocalha - DP761

Cover plate beam clamp.

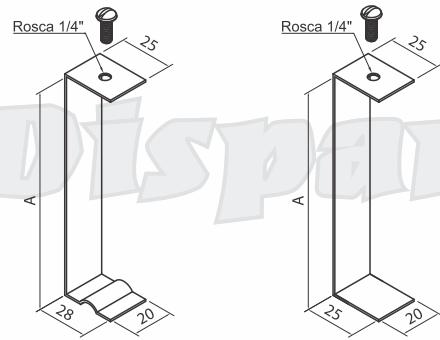

Presilha p/ eletrocalha perfurada.

Presilha p/ eletrocalha lisa.

Curva horizontal 90° raio curvilíneo - DP710C

Horizontal bend 90°

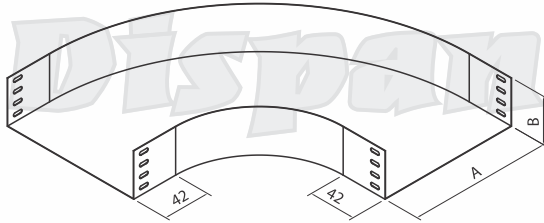

Indicar Cota A e B

Conexões especiais com raio curvilíneo

Curva horizontal 45° raio curvilíneo - DP711C

Horizontal bend 45°

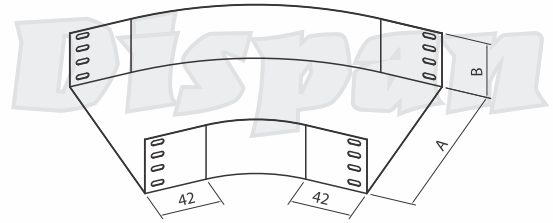

Indicar Cota A e B

Curva vertical externa 90° raio curvilíneo - DP712C

External vertical bend 90°

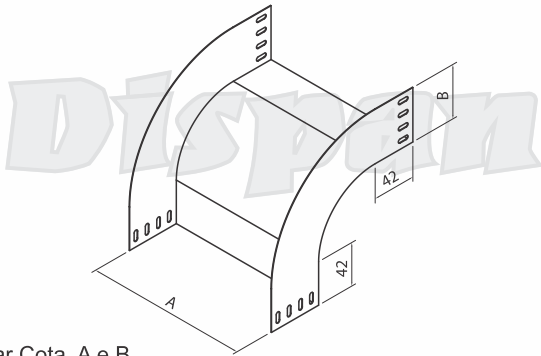

Indicar Cota A e B

Curva vertical externa 45° raio curvilíneo - DP713C

External vertical bend 45°

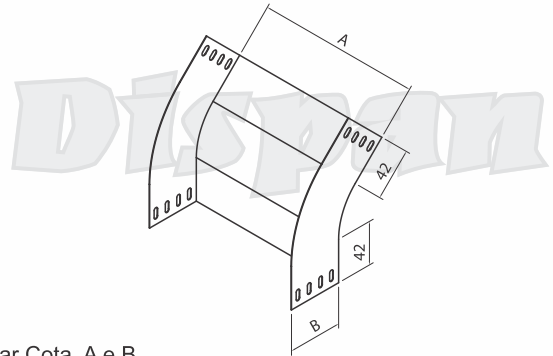

Indicar Cota A e B

Curva vertical interna 90° raio curvilíneo - DP714C

Internal vertical bend 90°

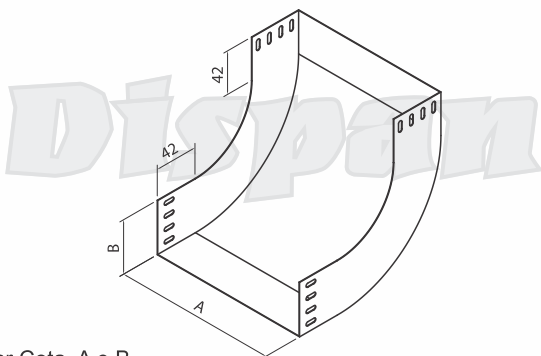

Indicar Cota A e B

Curva vertical interna 45° raio curvilíneo - DP715C

Internal vertical bend 45°

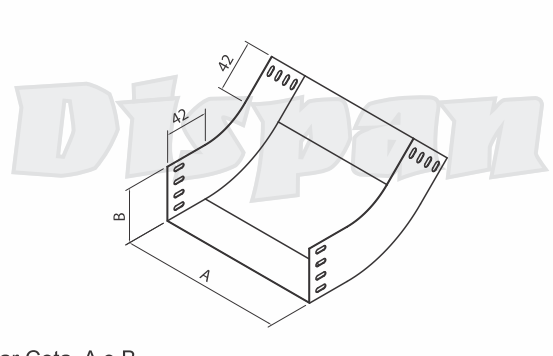

Indicar Cota A e B

Tê horizontal 90° raio curvilíneo - DP716C

Horizontal tee 90°

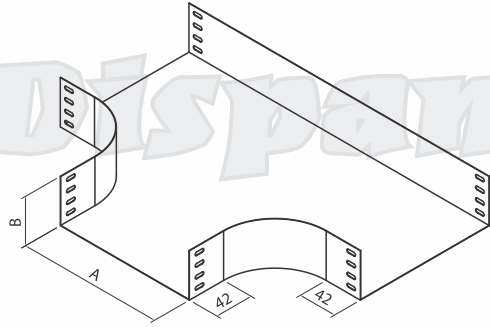

Indicar Cota A e B

Tê vertical de descida 90° raio curvilíneo - DP717C

Vertical descent tee 90°

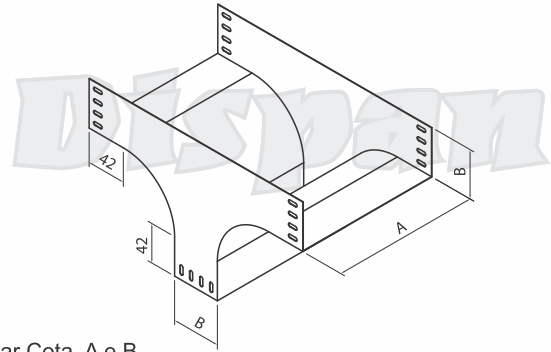

Indicar Cota A e B

Tê vertical de subida 90° raio curvilíneo - DP718C

Vertical ascent tee 90°

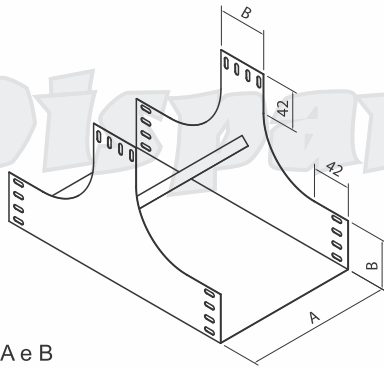

Indicar Cota A e B

Tê vertical de descida lateral 90° raio curvilíneo - DP719C

Lateral descent tee 90°

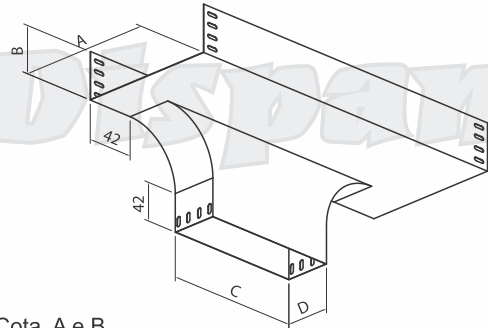

Indicar Cota A e B

Cruzeta horizontal 90° raio curvilíneo - DP720C

Horizontal cross 90°

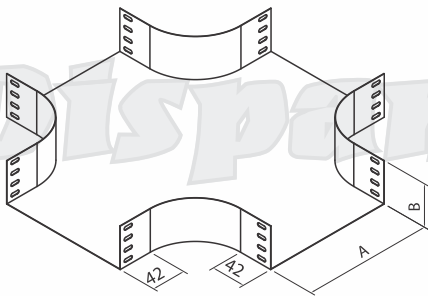

Indicar Cota A e B

Curva de inversão 90° raio curvilíneo - DP721C

Inversion bend 90°

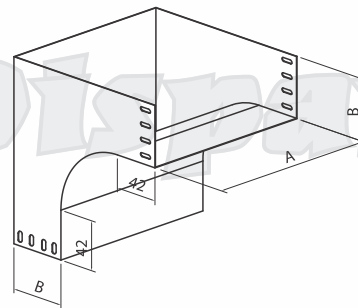

Indicar Cota A e B

Curva com passagem reta subida 90° raio curvilíneo - DP725C

90° Bend with ascent straight passage.

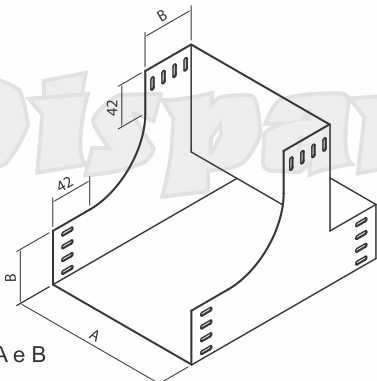

Indicar Cota A e B

Curva com passagem reta descida 90° raio curvilíneo - DP739C

90° Bend with downhill straight passage.

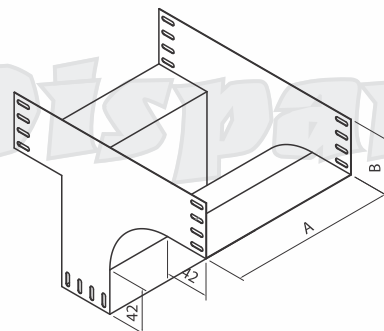

Indicar Cota A e B

Eletrocalha estrutural c/ virola 180°

Structural cable tray with ferrule 180°

A eletrocalha estrutural com virola 180°, foi desenvolvida pensando em aliar, economia, resistência mecânica e segurança no manuseio.

Com estas premissas, a Dispan criou esta nova linha de encaminhamento metálico para cabeados, já que o momento solicita um projeto econômico alinhado à resistência. O novo formato desta linha de eletrocalhas, atende normas nacionais e internacionais, quanto a resistência mecânica e segurança.

Testada e aprovada por empresa certificadora de renome em nacional, onde conseguimos superar nossas expectativas quanto a qualidade e resistência do produto final.

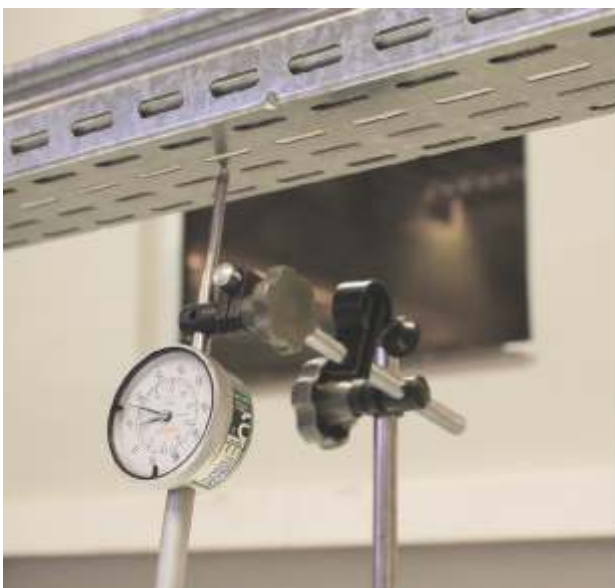

Como solicitar eletrocalhas estruturais

How to specify structural cable tray type.

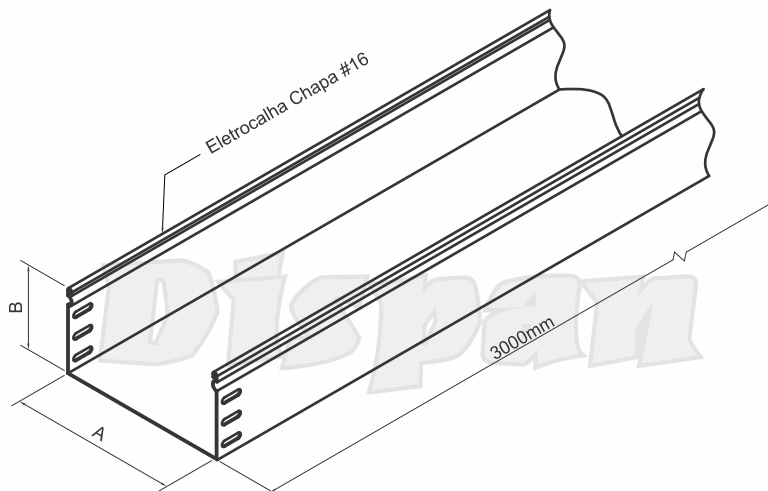

Exemplo
Example

DP701E - AC - GF - 400/100 - 16

Referência do catálogo de produtos com características básicas
Product catalog reference with basic features

Matéria-prima de fabricação
Manufacturing raw material

Acabamento
Finish

Largura / Altura da eletrocalha
Width / height of cable tray

Chapas de construção da eletrocalha
Cable tray construction plate

DP 701E - Eletrocalha lisa estrutural c/ virola 180°
DP 701E • Structural flat cable tray with ferrule 180°

Matéria-prima base
Raw material base
AC - Aço carbono
Carbon Steel

Acabamento aplicado na matéria-prima em base de aço carbono
Finish applied to the raw material in carbon steel base

GF - Galvanizado à fogo por imersão
Hot dip galvanized

GE - Galvanizado eletrolítico
Electrolytic galvanized

PZ - Pré-zincado
Pre-zincated

NT - Natural
Natural

PT - Pintado
Painting

Largura:
400 - Largura da eletrocalha desejada (De 50mm a 400 mm).
Width: 400 - width of the wanted cable tray (50mm to 400mm)

Altura:
100 - Altura da eletrocalha desejada (50mm / 75mm / 100mm).
Height: 100 - height of the wanted cable tray (50mm / 75mm / 100mm)

Chapas disponíveis = #16 / #18 / #20 / #22 / #24

Descritivo técnico | Technical description

DP 701E • Eletrocalha estrutural lisa com virola 180° em aço carbono, galvanizado à fogo, largura de 400mm com aba de 100mm em chapa #16.

Nota - 1

Ocasionalmente podem ocorrer algumas distorções de medidas em nossas peças, por diversos fatores. Por este motivo damos uma tolerância de 5,0 mm entre as medidas mencionadas no catálogo e as peças reais. Os furos oblongos são feitos exatamente para compensação e ajuste de eventuais diferenças.

Eletrocalha lisa estrutural com virola 180° - DP701E

Structural flat cable tray with ferrule 180°.

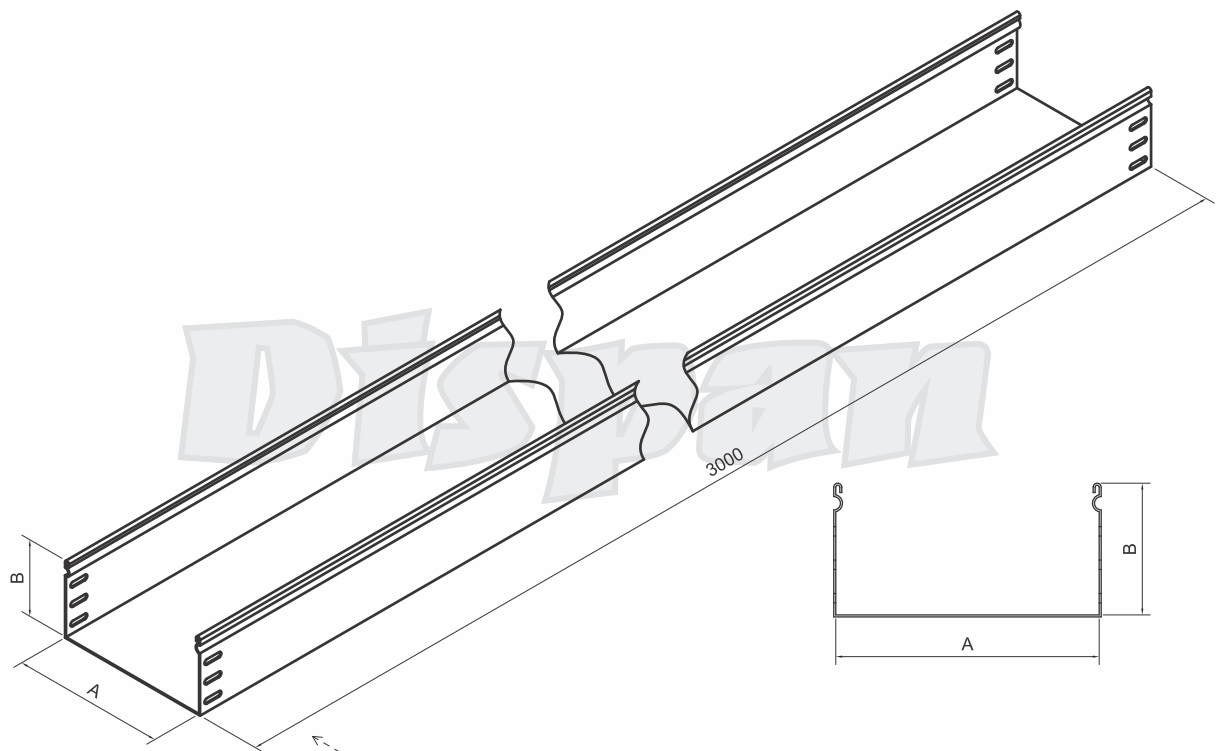

Aba de 50 mm

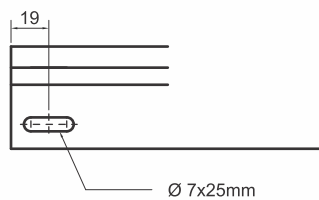

Aba de 75 mm

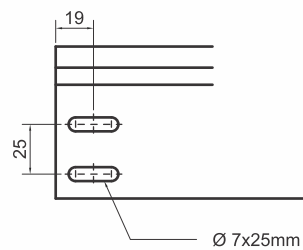

Aba de 100 mm

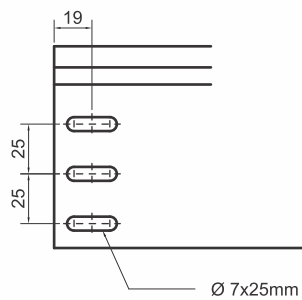

Eletrocalha perforada estrutural com virola 180° - DP703E

Perforated structural cabo tray with ferrule 180°

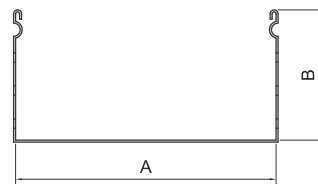
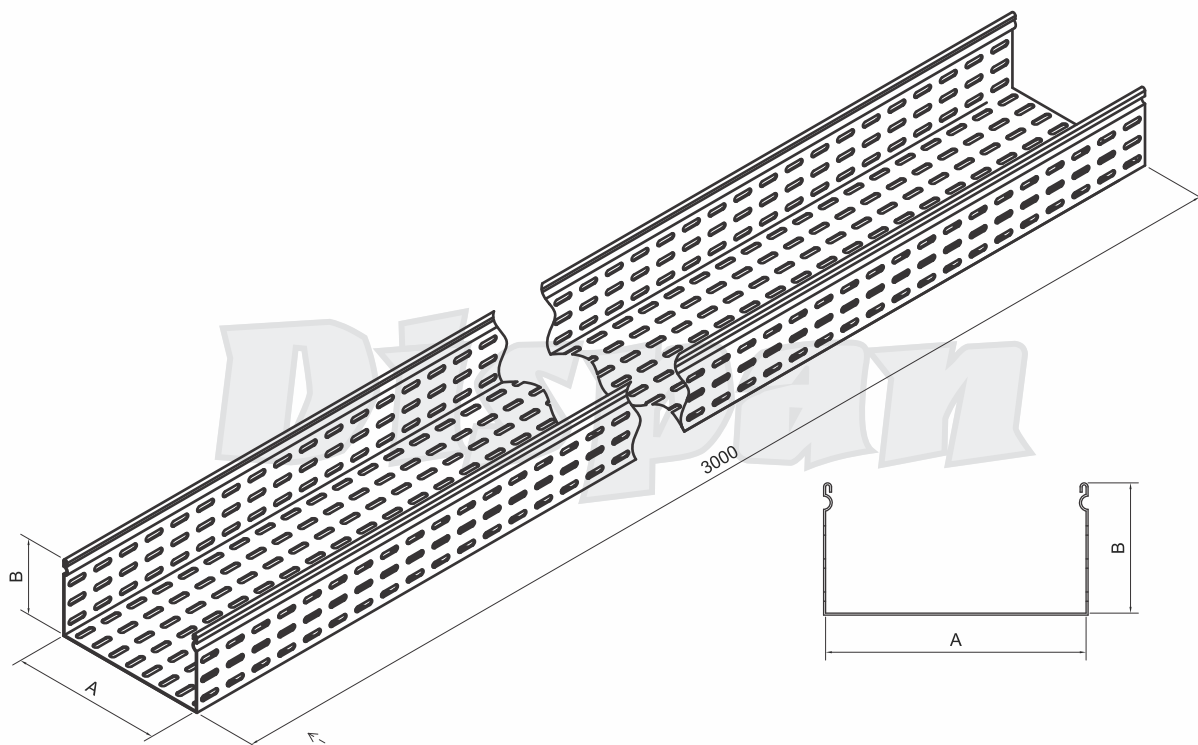

Aba de 50 mm

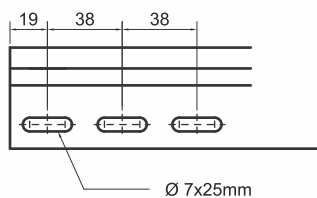

Aba de 75 mm

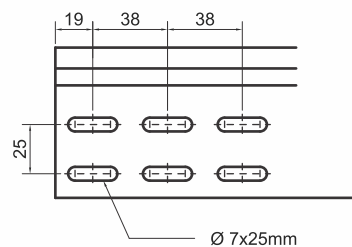

Aba de 100 mm

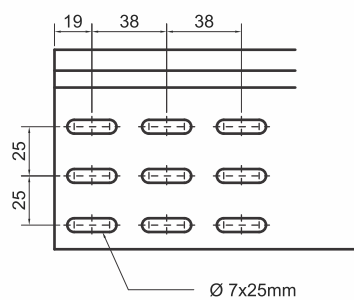

Como solicitar conexões para eletrocalhas

How to specify connections for cable tray type.

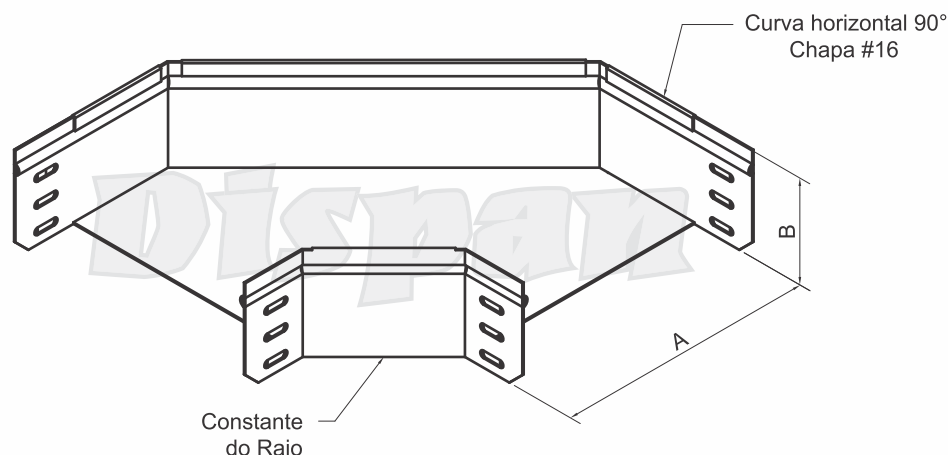

Exemplo
Example

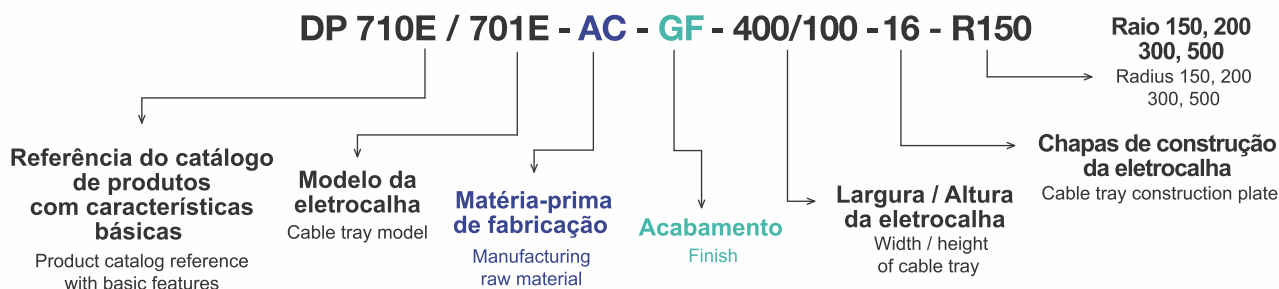

DP 710E • Curva horizontal 90° c/ virola 180°
DP 710E • Horizontal bend 90° with ferrule 180°

Matéria-prima base
Raw material base
AC - Aço carbono
Carbon Steel

Acabamento aplicado na matéria-prima em base de aço carbono
Finish applied to the raw material in carbon steel base

GF - Galvanizado à fogo por imersão
Hot dip galvanized

GE - Galvanizado eletrolítico
Electrolytic galvanized

PZ - Pré-zincado
Pre-zincated

NT - Natural
Natural

PT - Pintado
Painting

Largura:
400 - Largura da eletrocalha desejada (De 50mm a 400 mm).
Width: 400 - width of the wanted cable tray (50mm to 400mm)

Altura:
100 - Altura da eletrocalha desejada (50mm / 75mm / 100mm).
Height: 100 - height of the wanted cable tray (50mm / 75mm / 100mm)

Chapas disponíveis = #16 / #18 / #20 / #22 / #24

* Para solicitação da tampa, colocar o código + a letra "T".
Exemplo = DP710ET

Descritivo técnico | Technical description

DP 710E • Curva horizontal 90° para eletrocalha estrutural lisa com virola 180°, em aço carbono, galvanizado à fogo largura de 400mm, com aba de 100mm em chapa #16 raio de 150mm, segmentada.

Nota - 1

Ocasionalmente podem ocorrer algumas distorções de medidas em nossas peças, por diversos fatores. Por este motivo damos uma tolerância de 5,0 mm entre as medidas mencionadas no catálogo e as peças reais. Os furos oblongos são feitos exatamente para compensação e ajuste de eventuais diferenças.

**Curva horizontal 90° raio segmentado
DP710E**

Horizontal bend - 90°

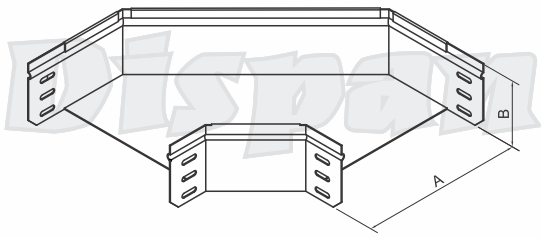

Indicar cota A e B.

**Curva horizontal 45° raio segmentado
DP711E**

Horizontal bend - 45°

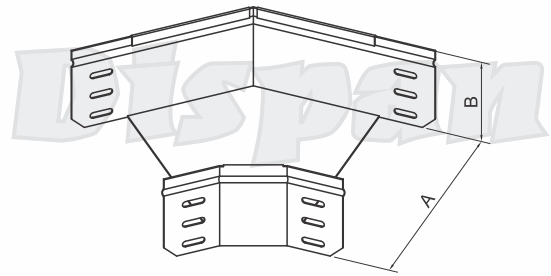

Indicar cota A e B.

**Curva vertical externa 90°
raio segmentado - DP712E**

External vertical bend - 90°

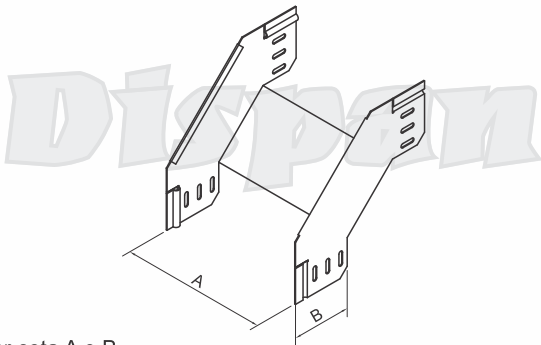

Indicar cota A e B.

**Curva vertical externa 45°
raio segmentado - DP713E**

External vertical bend - 45°

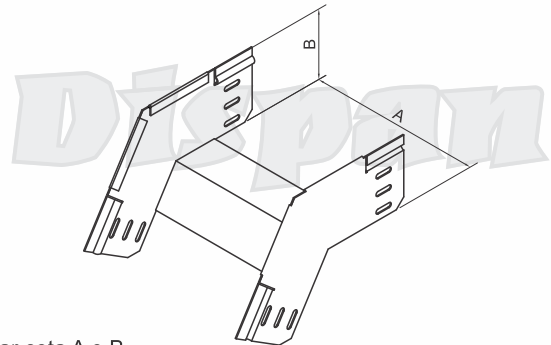

Indicar cota A e B.

**Curva vertical interna 90°
raio segmentado - DP714E**

Internal vertical bend - 90°

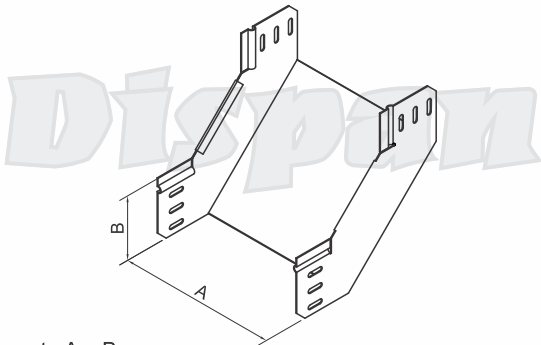

Indicar cota A e B.

**Curva vertical interna 45°
raio segmentado - DP715E**

Internal vertical bend - 45°

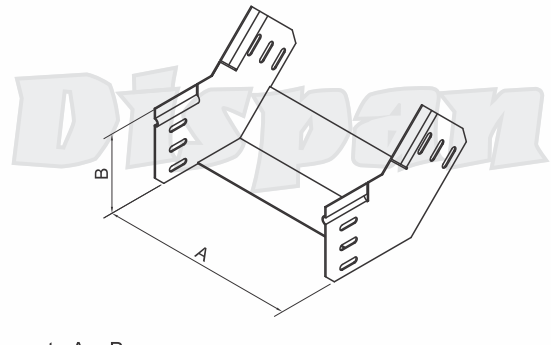

Indicar cota A e B.

**Te horizontal 90° raio segmentado
DP716E**

Horizontal tee - 90°

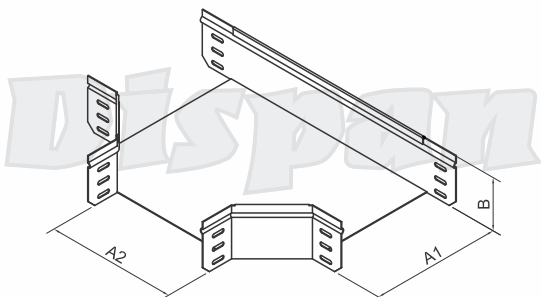

Indicar cota A e B.

**Te vertical de descida 90°
raio segmentado - DP717E**

Vertical descent tee - 90°

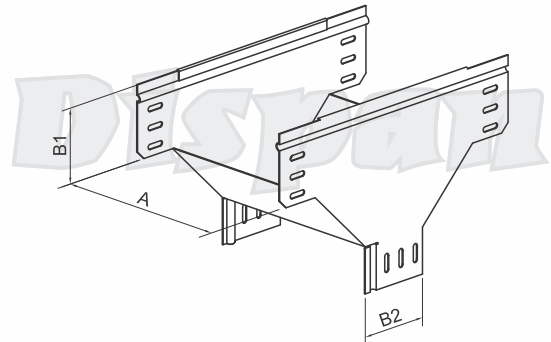

Indicar cota A e B.

**Te vertical de subida 90°
raio segmentado - DP718E**

Vertical ascent tee - 90°

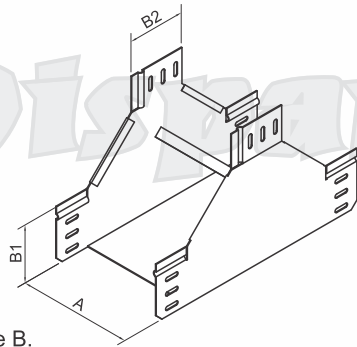

Indicar cota A e B.

**Te vertical de descida lateral 90°
raio segmentado - DP719E**

Lateral descent tee - 90°

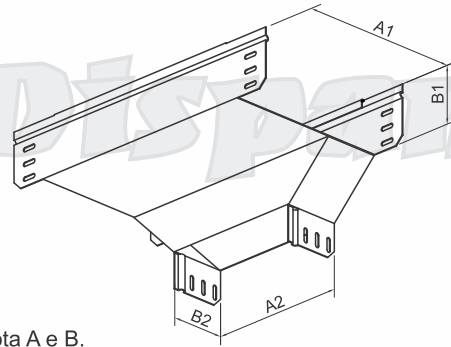

Indicar cota A e B.

**Cruzeta horizontal 90°
raio segmentado - DP720E**

Horizontal cross - 90°

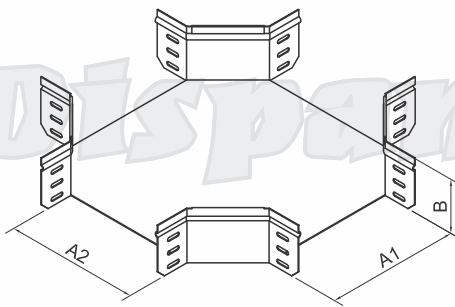

Indicar cota A e B.

**Curva de inversão 90°
raio segmentado - DP721E**

Inversion bend - 90°

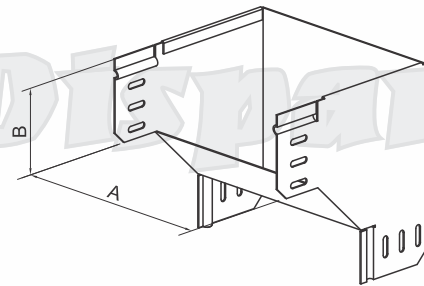

Indicar cota A e B.

Te reto 90° - DP722E

Straight tee

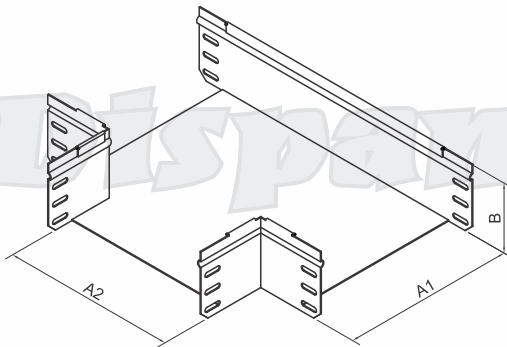

Indicar cota A e B.

Cotovelo reto 90° - DP723E

Elbow 90°

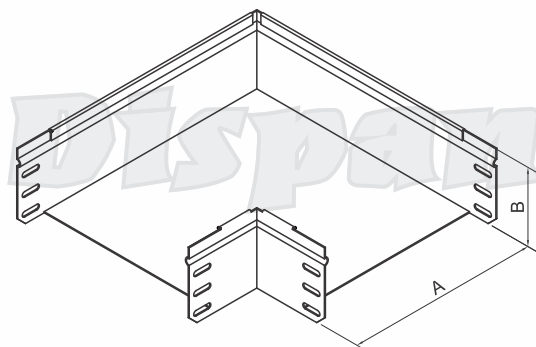

Indicar cota A e B.

Cruzeta reta 90° - DP724E

Straight cross

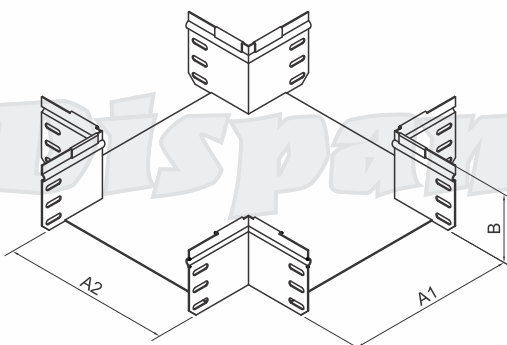

Indicar cota A e B.

**Curva com passagem reta subida 90°
raio segmentado - DP725E**

90° Bend with ascent straight passage

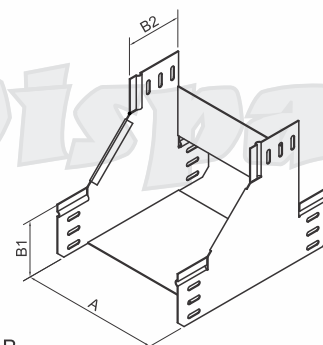

Indicar cota A e B.

Segmento de montagem - DP760

Coupling enter connections

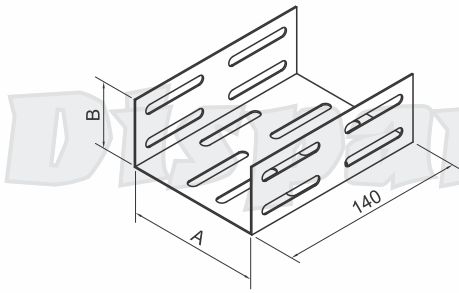

Indicar cota A e B.

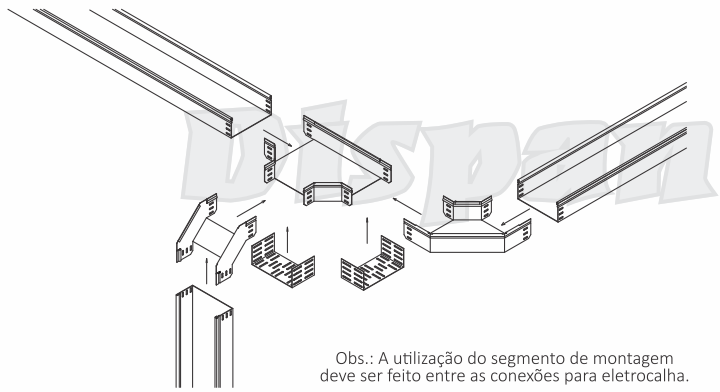

Obs.: A utilização do segmento de montagem deve ser feito entre as conexões para eletrocalha.

Junção à direita 45° - DP726E

Right junction

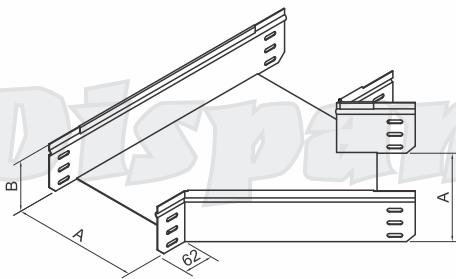

Indicar cota A e B.

Junção à esquerda 45° - DP727E

Left junction

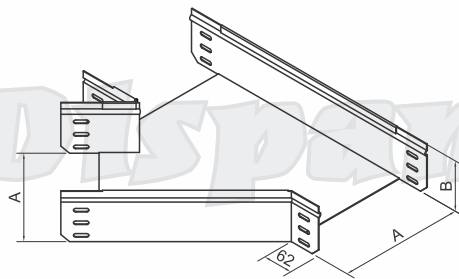

Indicar cota A e B.

Curva com passagem reta descida 90° raio segmentado - DP739E

Bend with descent straight passage

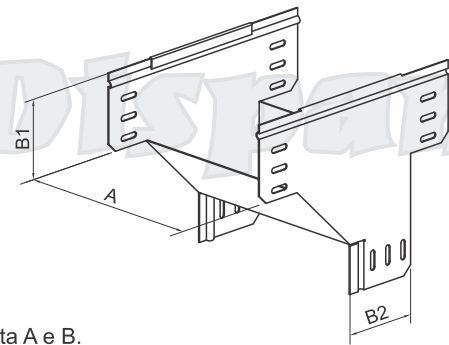

Indicar cota A e B.

Presilha para tampa em eletrocalha DP761

Cover plate beam clamp

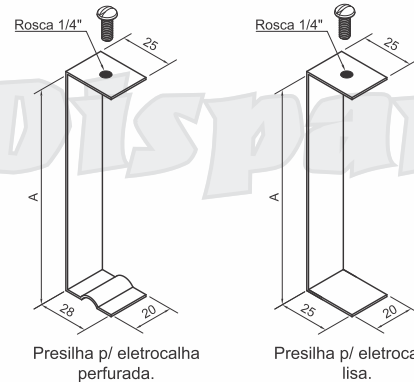

Presilha p/ eletrocalha
perfurada.

Presilha p/ eletrocalha
lisa.

Desvio horizontal à esquerda 45° DP728E

Left deviation

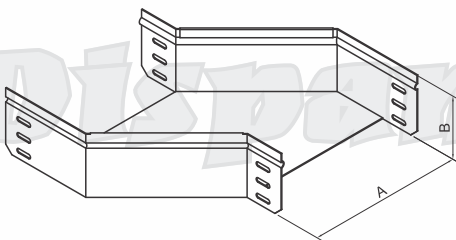

Indicar cota A e B.

Desvio horizontal à direita 45° DP729E

Right deviation

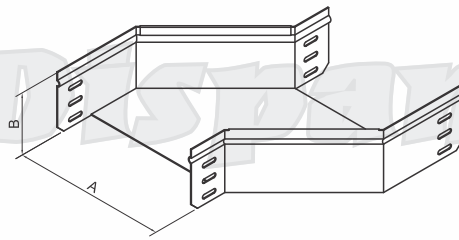

Indicar cota A e B.

Redução concêntrica - DP730E

Concentric reduction

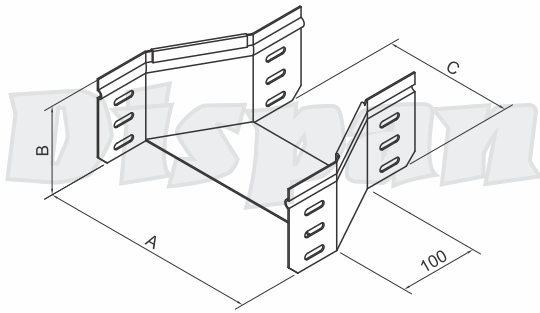

Indicar cota A e B.

Redução à direita - DP731E

Right reduction

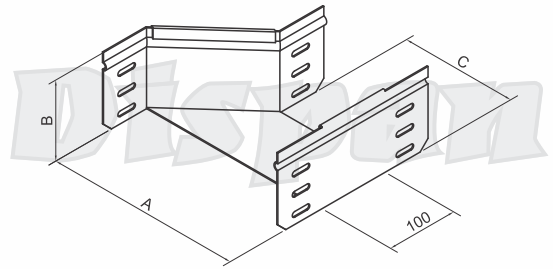

Indicar cota A e B.

Redução à esquerda - DP732E

Left reduction

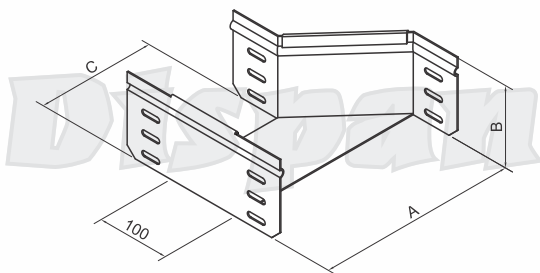

Indicar cota A e B.

Redução de abas - DP733E

Beam reduction

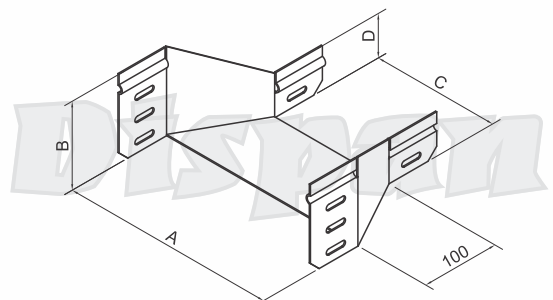

Indicar cota A e B.

Terminal liso para eletrocalha - DP737E

End plate

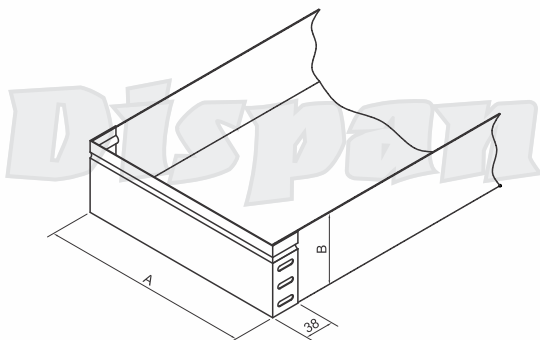

Indicar cota A e B.

Gotejador - DP738E

Dropout

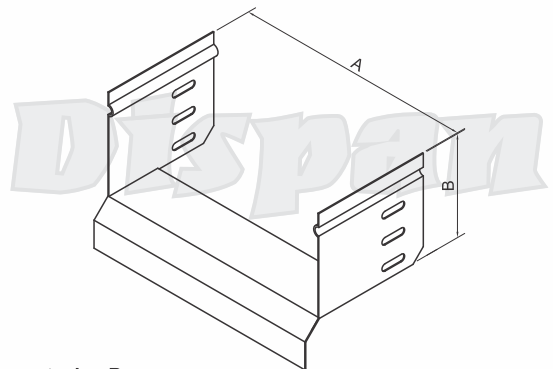

Indicar cota A e B.

Esquema de montagem p/ tala

Typical applications

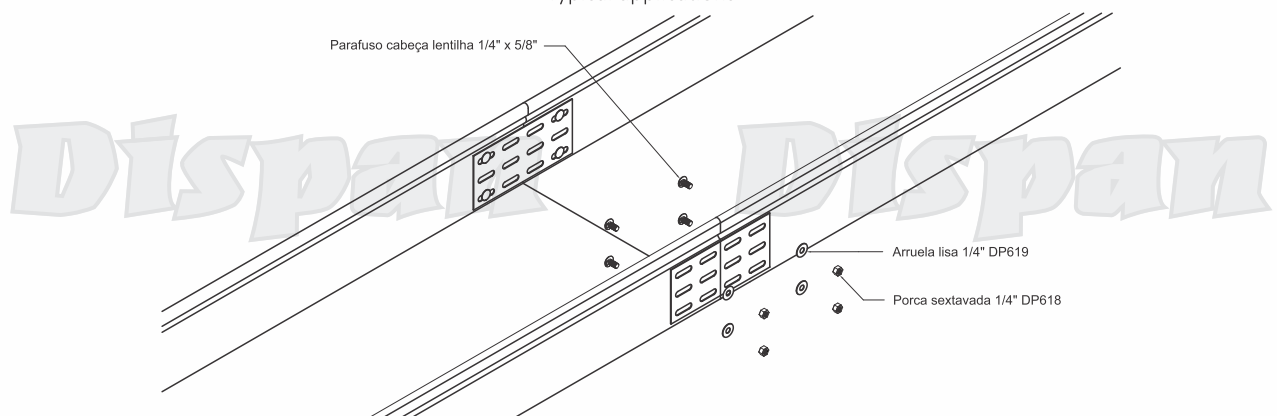

**Terminal com saída para eletroduto
DP753E**

Bottom outlet

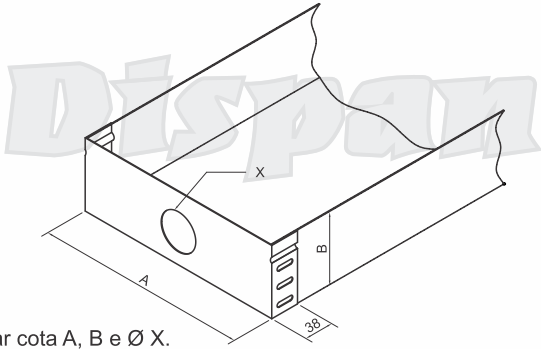

Indicar cota A, B e Ø X.

**Terminal com saída para
perfilado 38x38 - DP765E**

Channel outlet

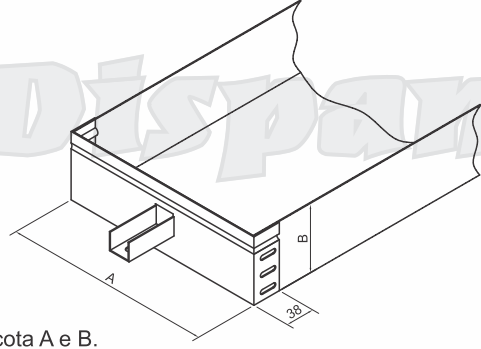

Indicar cota A e B.

**Terminal com saída para
perfilado 38x76 - DP766E**

Channel outlet

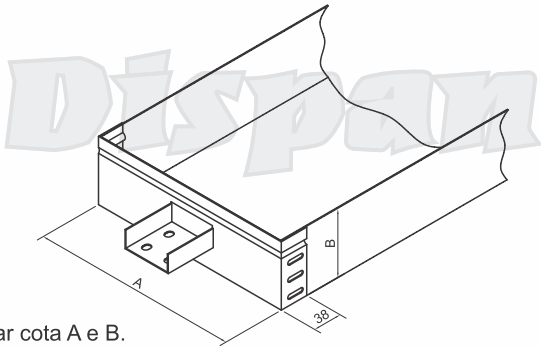

Indicar cota A e B.



Flange para ligação em painel - DP734

Box connector.

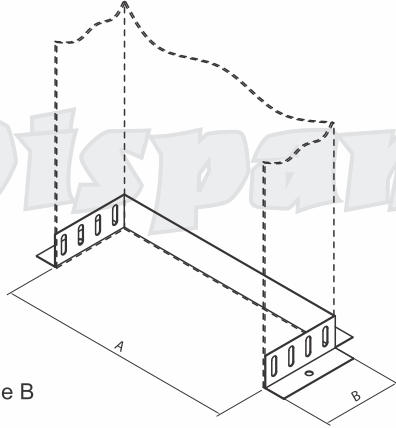

Indicar Cota A e B

Emenda interna perforada - DP736

Telescopic splice.

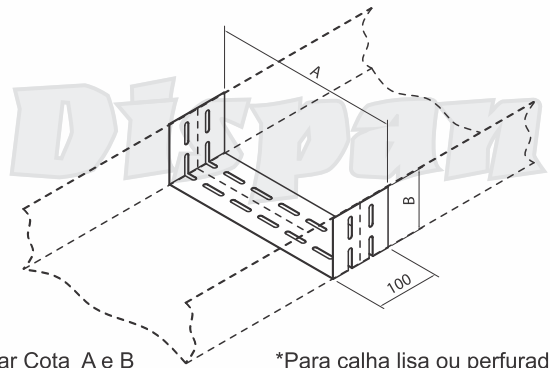

Indicar Cota A e B

*Para calha lisa ou perforada.

Terminal liso para eletrocalha - DP737

End plate.

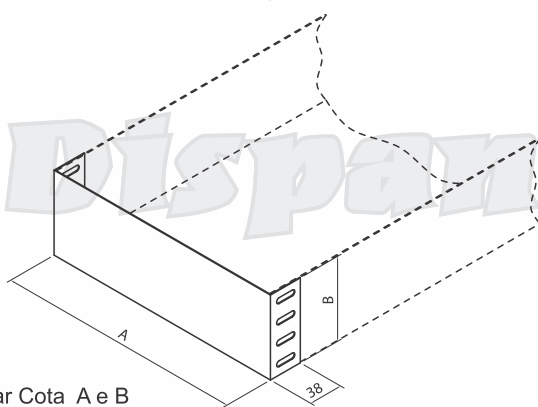

Indicar Cota A e B

Gotejador - DP738

Dropout.

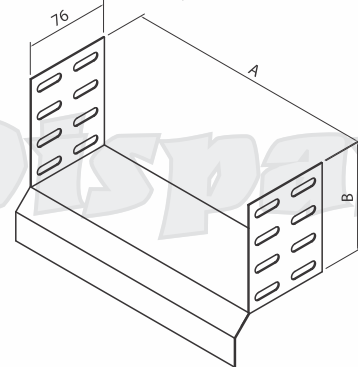

Indicar Cota A e B

Tala para eletrocalha perforada - DP740

Single splice pate.

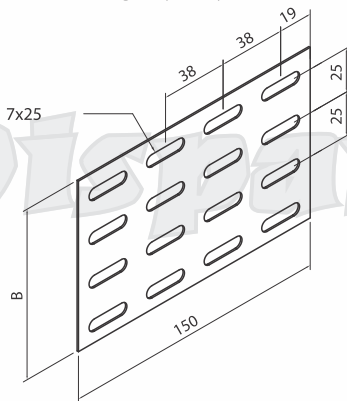

Indicar Cota B

Tala curta perforada - DP741

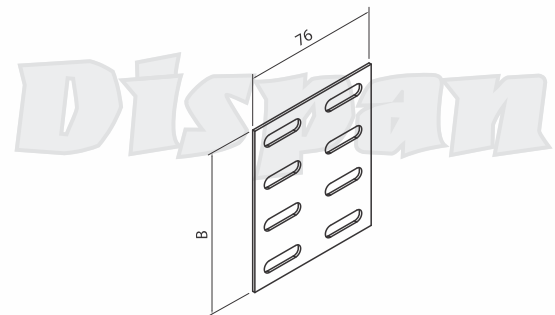

Indicar Cota B

Suporte horizontal - DP742

Horizontal hanger.

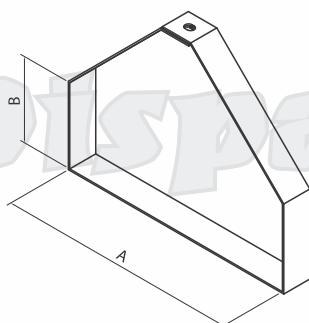

Obs.: De acordo com as dimensões das eletrocalhas.

Suporte vertical - DP743

Vertical hanger.

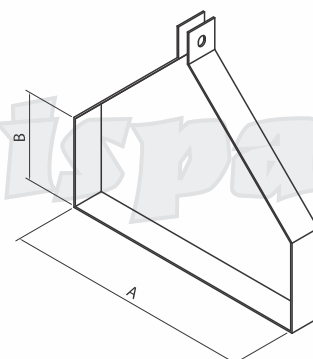

Obs.: De acordo com as dimensões das eletrocalhas.

Suporte duplo - DP744

Double support.

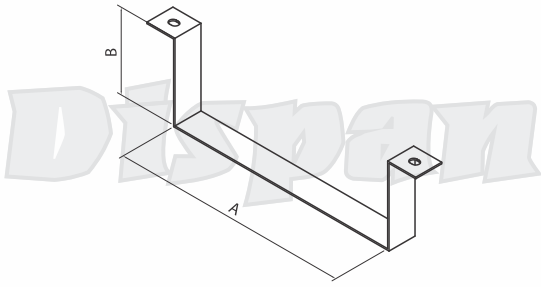

Obs.: De acordo com as dimensões das eletrocalhas.

Suporte reforçado - DP745

Reinforced support.

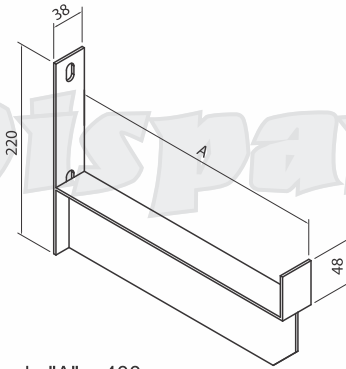

Largura máxima de "A" = 400 mm.

Carga uniformemente distribuída em mão francesa.

Uniformly distributed loads on bracket.

Carga distribuída

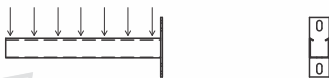

Carga distribuída

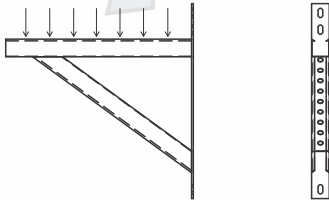

Carga distribuída

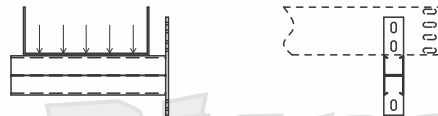

Carga distribuída

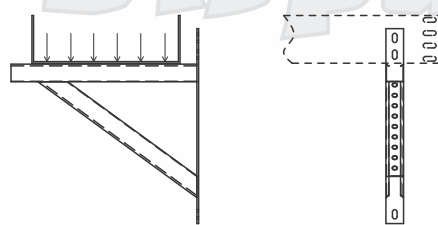

Mão francesa simples - 746

Single bracket.

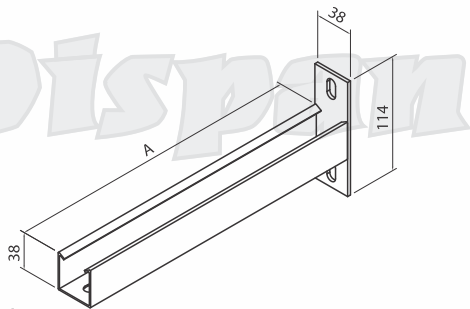

Indicar Cota A

Mão francesa dupla - 747

Double bracket.

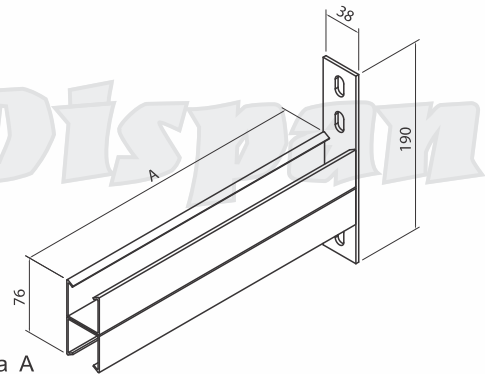

Indicar Cota A

Mão francesa reforçada - 748

Reinforced bracket.

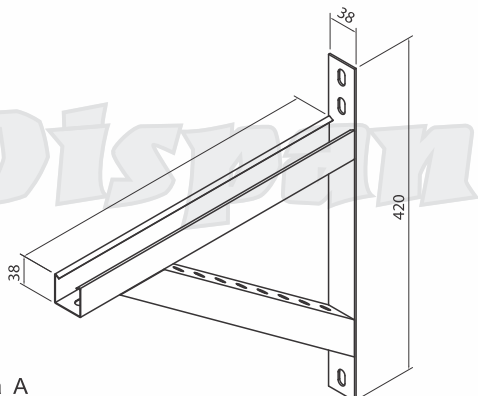

Indicar Cota A

Acoplamento de eletrocalha p/ perfilado 38x38 mm - DP749

Upper outlet - cable tray 38x38 mm

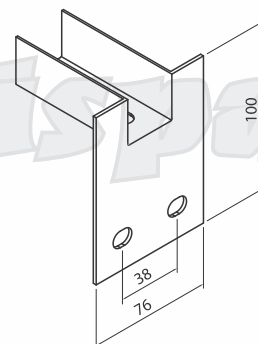

Acoplamento de eletrocalha p/ perfilado 38x76 mm - DP750

Upper outlet- cable tray 38x76 mm.

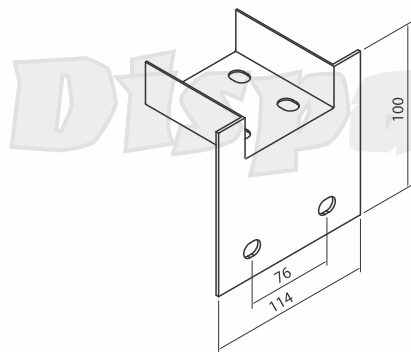

Saída horizontal para eletroduto - DP751

Upper or lower horizontal outlet.

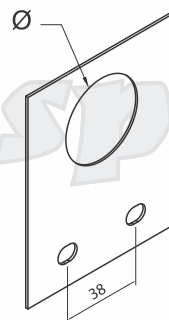

Indicar o Ø.

Saída vertical para eletroduto - DP752

Upper or lower vertical outlet.

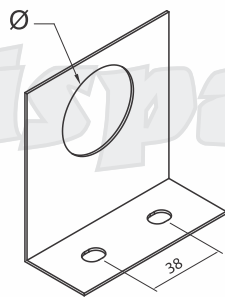

Indicar o Ø.

Terminal com saída para eletroduto - DP753

Bottom outlet.

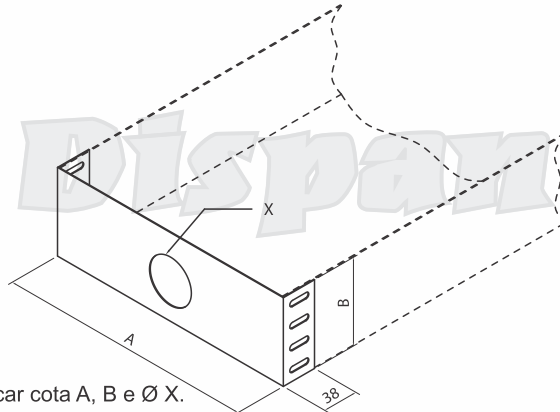

Indicar cota A, B e Ø X.

Junção articulada perfurada p/ eletrocalha - DP755

Flexible splice for cable trays.

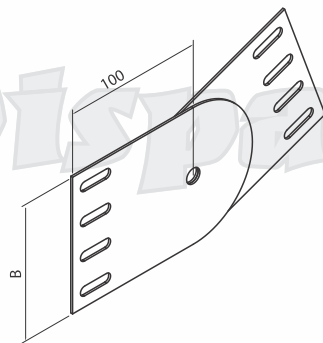

Indicar cota B.

Junção redutora excêntrica p/ eletrocalha - DP757

Reducing junction.

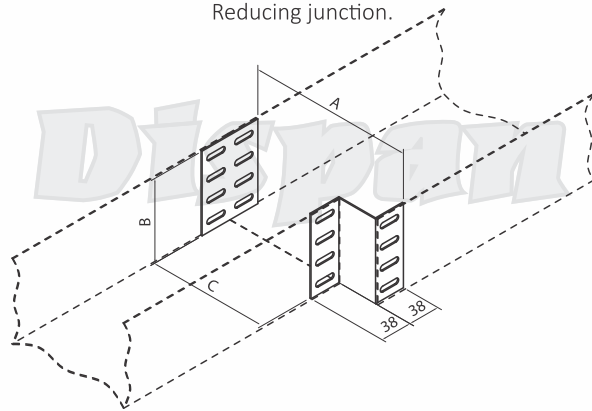

Junção redutora concêntrica p/ eletrocalha - DP758

Concentric reduction.

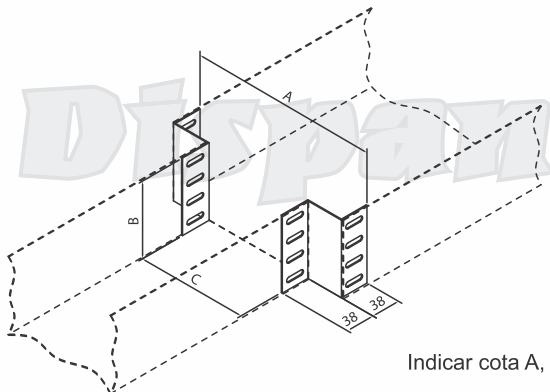

Indicar cota A, B e C.

Terminal com saída para Perfilado 38x38 - DP765

Channel outlet.

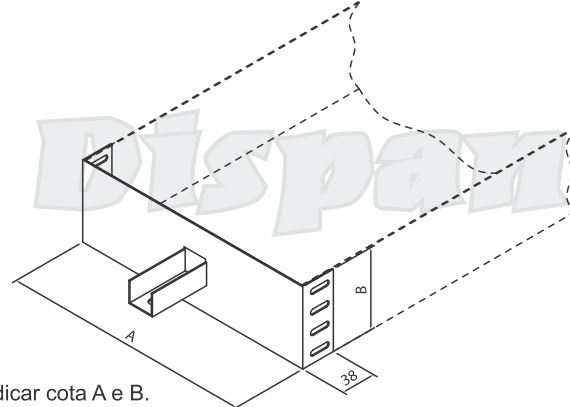

Indicar cota A e B.

Terminal com saída para Perfilado 38x76 - DP766

Channel outlet.

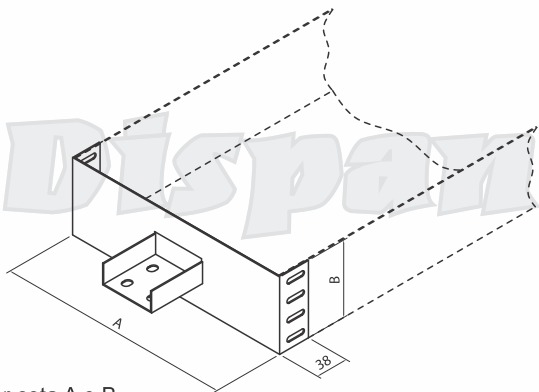

Indicar cota A e B.

Guarnição de borracha p/ eletrocalha - DP762

Rubber protection for cable tray channel type.

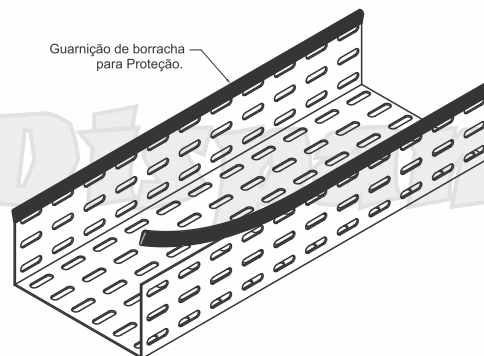

Obs.: Informar o comprimento total.
*Venda a parte.

Cinta para fechamento de tampa para eletrocalha DP763-C

Supportand and belt for cable trays channel type.

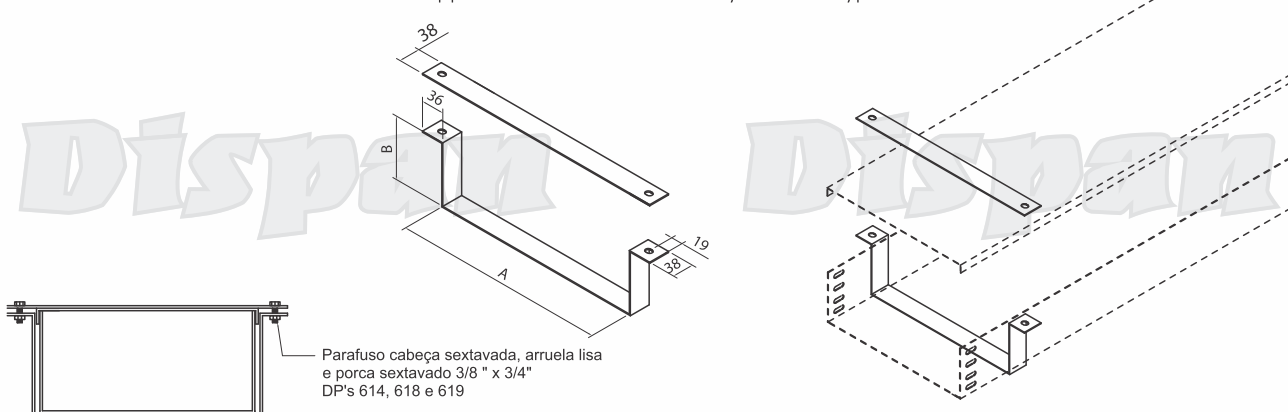

Mata junta para Eletrocalha - DP859E

Closing to anglo cover.

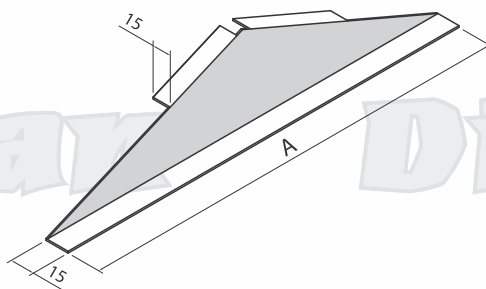

Obs.: As mata juntas são necessárias, todas as vezes que houver um encontro de conexões e trechos reto de leito utilizando tampa 2 águas.

Esquema de montagem para mata junta para Eletrocalha

Typical applications of the closing to anglo cover.

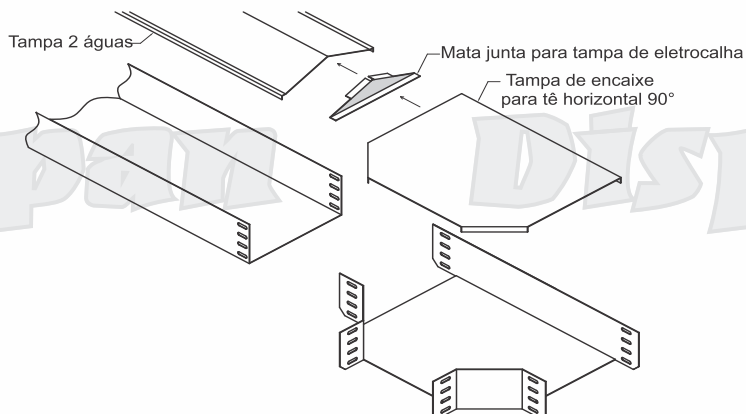

Junção horizontal articulada para eletrocalha - DP764

Horizontal articulated junction.

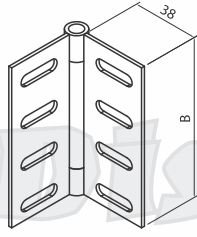

Indicar cota B.

Ajuste manual de acordo com a angulação desejada.

Junção vertical de subida - DP775

Vertical rise junction

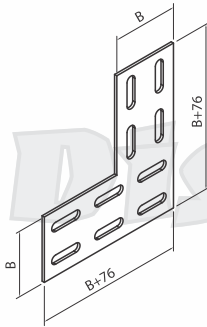

Junção redutora excêntrica ajustável - DP776

Reductive eccentric junction ajustable

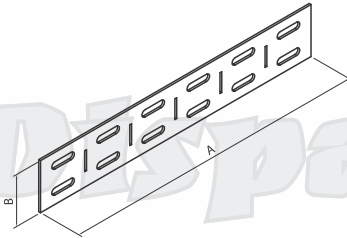

Indicar cota B.





Perfilados

Steel profiled



PERFILADOS		PERFILADOS		PERFILADOS		PERFILADOS	
Cód. dos Materiais	Ver Página	Cód. dos Materiais	Ver Página	Cód. dos Materiais	Ver Página	Cód. dos Materiais	Ver Página
DP502	57	DP540	61	DP579	66	DP617	72
DP503	57	DP541	62	DP580	66	DP618	73
DP504	57	DP542	62	DP581	67	DP619	73
DP505	57	DP543	62	DP582	67	DP620	73
DP506	57	DP544	62	DP583	67	DP621	73
DP507	57	DP546D	62	DP584	59 / 67	DP622	73
DP508	57	DP546E	62	DP585	67	DP623	73
DP509	57	DP547	62	DP586	67	DP624N	73
DP510	58	DP548	63	DP587	67	DP624P	73
DP511	58	DP549	63	DP588	67	DP625	73
DP512	58	DP550	63	DP589	67	DP625CJ	74
DP513	58	DP551	63	DP590	68	DP626	74
DP514	58	DP552	63	DP591	68	DP627	74
DP515	58	DP553	63	DP592	68	DP628	74
DP516	58	DP554	63	DP593	68	DP629	74
DP517	58	DP555	63	DP594	68	DP630	74
DP518	59	DP556	64	DP595	68	DP630P	76
DP519	59	DP557	64	DP596	68	DP631	74
DP520	59	DP558	64	DP597	68	DP632	75
DP521	59	DP559	64	DP598	68	DP633	75
DP522	59	DP560	64	DP599	69	DP634	75
DP523	59	DP561	64	DP600	69	DP635	75
DP524	74	DP562	64	DP601	69	DP636	75
DP525	59	DP563	64	DP602	69	DP637	75
DP526	60	DP564	65	DP603	69	DP638	76
DP527	60	DP565	65	DP604	69	DP639	76
DP528	60	DP566	65	DP605	69	DP640	76
DP529	60	DP567	65	DP606	69	DP641	70
DP530	60	DP568	65	DP607-D	69	DP642	70
DP531	60	DP569	65	DP607-E	70	DP643	70
DP532	60	DP570	65	DP608	71	DP644	70
DP533	60	DP571	65	DP609	71	DP645	70
DP534	61	DP572	66	DP610	71	DP646	70
DP535	61	DP573	66	DP611	71	DP647	70
DP536	61	DP574	66	DP612	72	DP648	70
DP536R	61	DP575	66	DP613	72	DP649	71
DP537	61	DP576	66	DP614	72	DP650	71
DP538	61	DP577	66	DP615	72	DP651	71
DP539	61	DP578	66	DP616	72	DP652 / DP653	71

Anotações

Dispan

Como solicitar perfilados

How to specify channels.

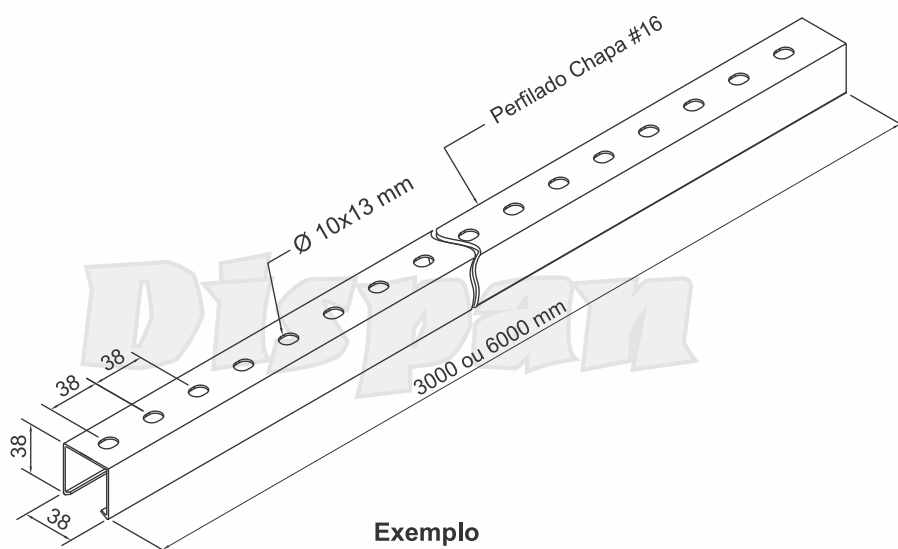

Exemplo
Example

DP502 - AC - GF - 6000 - 16

Referência do catálogo
de produtos
com características
básicas

Product catalog reference
with basic features

**Matéria-prima
de fabricação**

Manufacturing
raw material

Acabamento
Finish

**Comprimento
do perfilado**
Steel profiled length

**Chapas de construção
do perfilado**

Steel profiled construction's plates

DP 502 • Perfilado perfurado 38 X 38 X 6000 mm
DP 502 • Perforated steel profiled 38 x 38 x 6000 mm

Matéria-prima base
Raw material base

AC - Aço carbono
Carbon Steel

AI - Aço inox
Stainless Steel

AL - Alumínio
Aluminum

**Acabamento aplicado na matéria-prima
em base de aço carbono**
Finish applied to the raw material in carbon steel base

GF - Galvanizado à fogo por imersão
Hot dip galvanized

GE - Galvanizado eletrolítico
Electrolytic galvanized

PZ - Pré-zincado
Pre-zincated

NT - Natural
Natural

PT - Pintado
Painting

Comprimento:
3000 mm / 6000 mm
Length: 3000 mm / 6000 mm

Espessuras de chapas:
16 - Chapa do perfilado
Plate thickness: 16 - steel profiled plate

* Chapas disponíveis = #12 / #14 / #16 / #18 / #20 / #22 / #24.

Descritivo técnico | Technical description

DP 502 • Perfilado perfurado 38 X 38 X 6000 mm, em aço carbono, galvanizado à fogo, em chapa #16.
DP 502 • Perforated steel profiled 38 x 38 x 6000 mm, carbon steel, hot dip galvanized, plate #16.

Nota

Ocasionalmente podem ocorrer algumas distorções de medidas em nossas peças, por diversos fatores. Por este motivo damos uma tolerância de 5,0 mm entre as medidas mencionadas no catálogo e as peças reais. Os furos oblongos são feitos exatamente para compensação e ajuste de eventuais diferenças.

Note

Occasionally, it may occur some distortion of measures in our pieces, for several reasons. Because of this, we give a toleration of 5.0 mm between the measures mentioned in this catalog and the real pieces. The slotted holes are made just for clearing and settling of any possible differences.

Perfilado perfurado 38x38x6000 mm - DP502

With perforations.

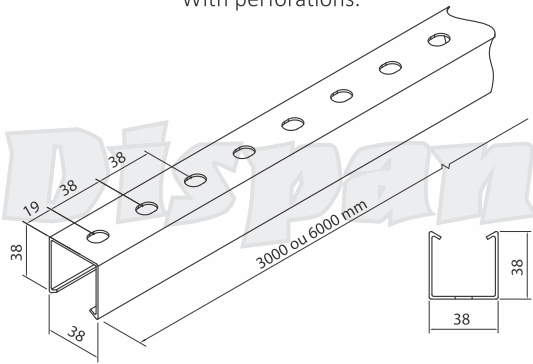

Perfilado c/ 2 furos nas pontas 38x38x6000mm - DP503

With 2 holes at the ends.

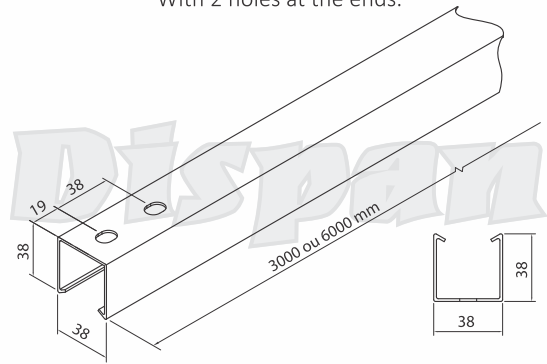

Perfilado perfurado 19x38x6000mm - DP504

With perforations.

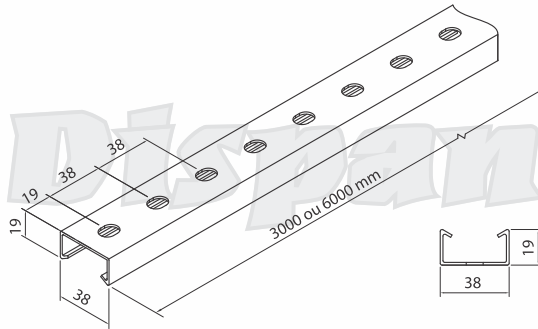

Perfilado liso 19x38x6000 mm - DP505

With solid base.

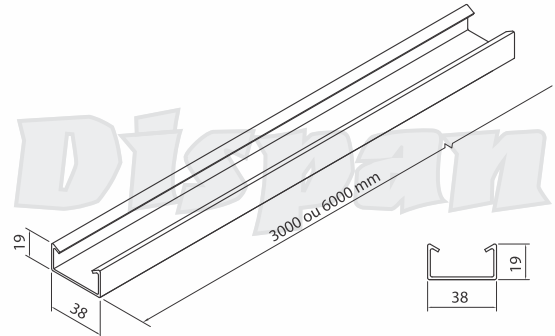

Perfilado liso com 4 furos 38x76x3000 mm - DP506

Double, with 4 holes at the ends.

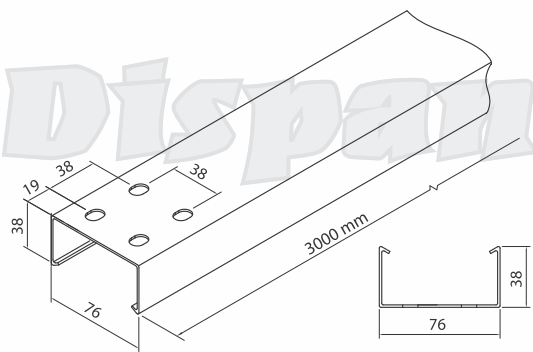

Perfilado perfurado 38x76x3000 mm - DP507

Double, with perforations.

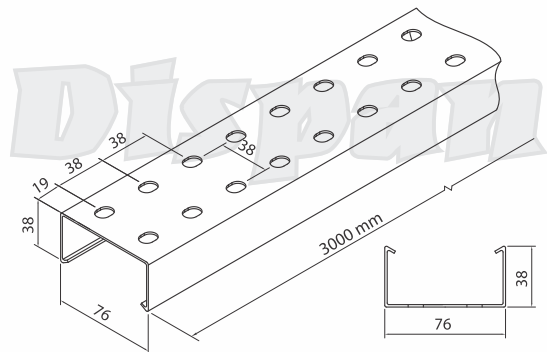

Perfilado conjugado 38x76x6000 mm - DP508

Welded channel combination.

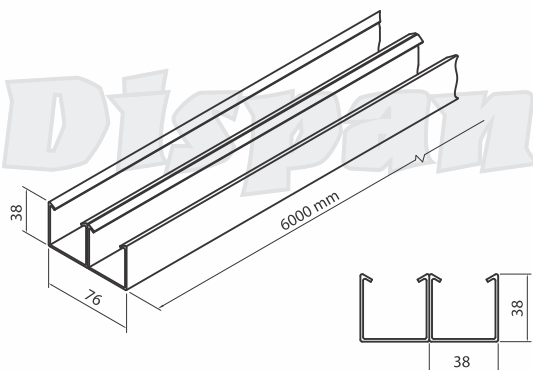

Perfilado conjugado 38x114x6000 mm - DP509

Welded channel combination.

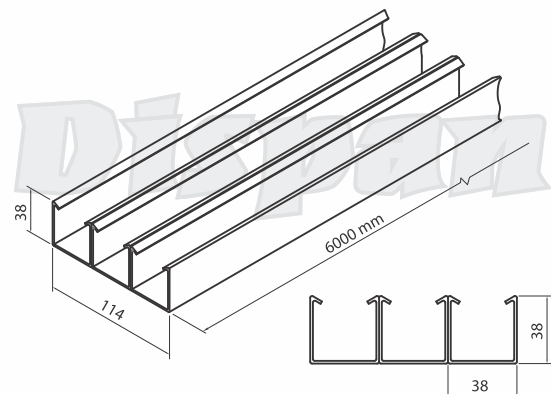

Perfilado conjugado 38x76x6000 mm - DP510

Horizontal articulated junction.

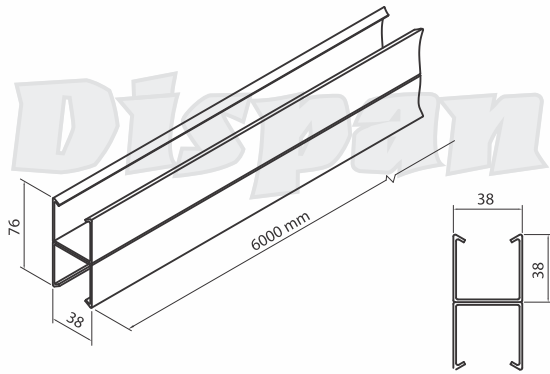

Perfilado conjugado 38x76x6000 mm - DP511

Welded channel combination.

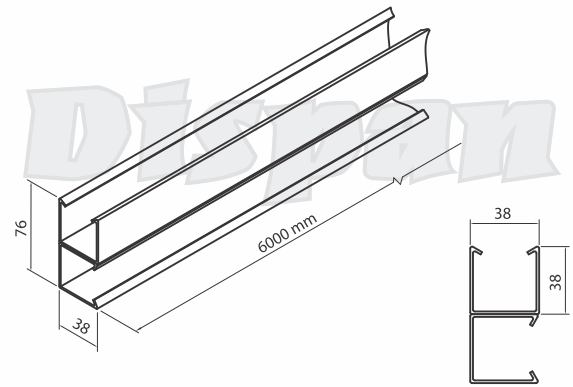

Tampa de encaixe p/ perfilado 38x3000 mm - DP512

Channel insert cover - 38mm.

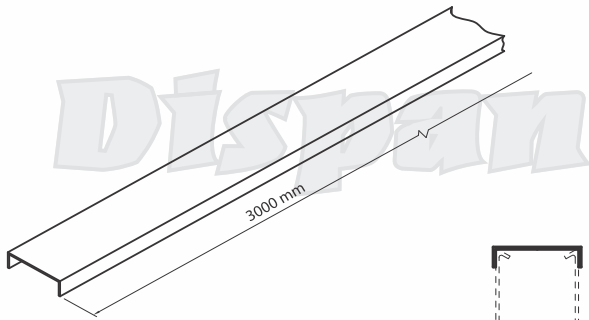

Montagem da tampa no perfilado.

Tampa de pressão p/ perfilado 38x3000 mm - DP513

Channel pressure cover - 38mm.

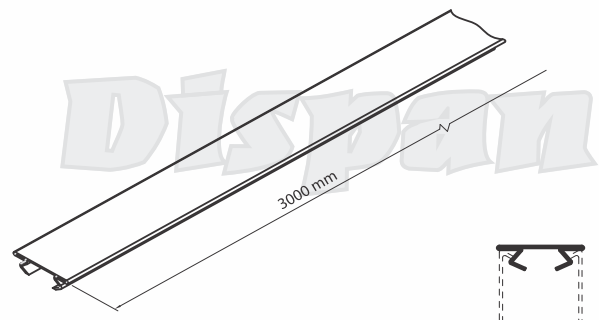

Montagem da tampa no perfilado.

Tampa de encaixe p/ perfilado duplo 76x3000 mm - DP514

Channel insert cover - 76 mm.

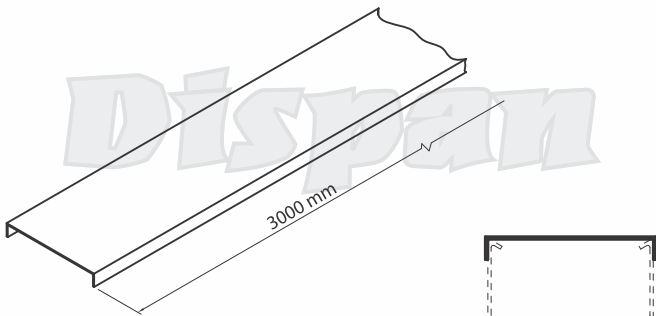

Montagem da tampa no perfilado.

Tampa de pressão p/ perfilado duplo 76x3000 mm - DP515

Channel pressure cover - 76 mm.

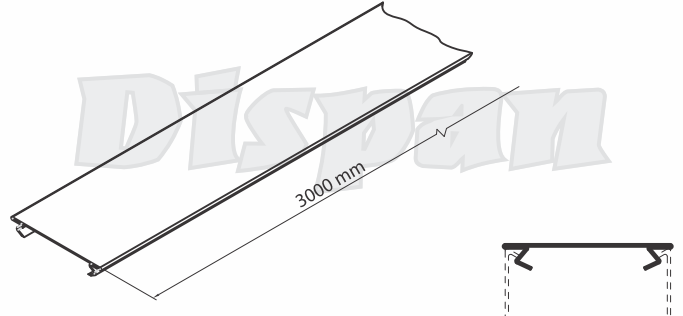

Montagem da tampa no perfilado.

Fita chata perfurada 38x3000 mm - DP516

Perforated belt.

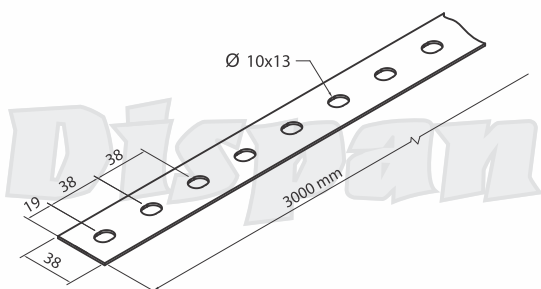

Fabricação nas chapas:
Chapa #16, #14 e #12

Cantoneira "L" 38x38x3000 mm - DP517

Perforated angle.

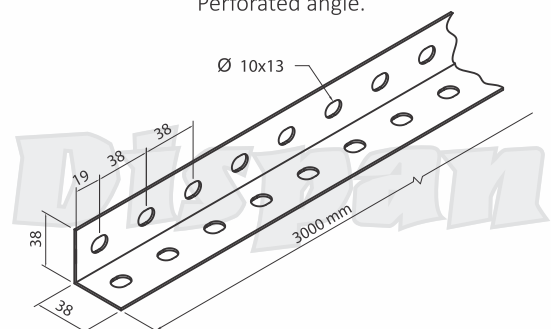

Fabricação nas chapas:
Chapa #16, #14 e #12

Emenda externa "I" - DP518

External channel joinder "I"

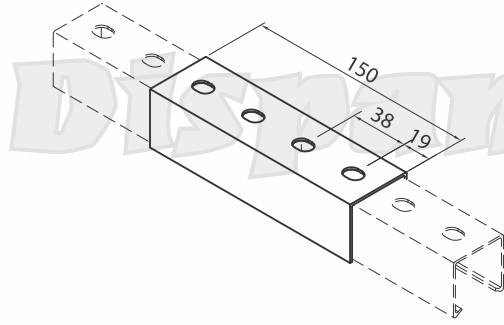

Emenda interna "I" - DP519

Internal channel joinder "I"

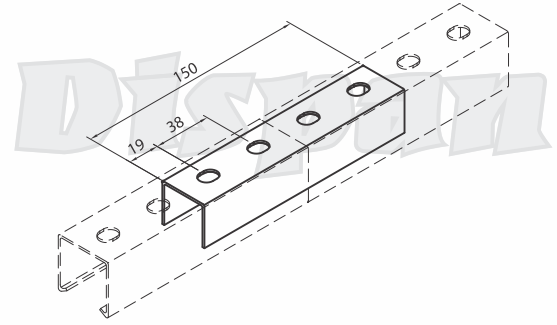

Emenda interna "L" - DP520

Internal channel joinder "L"

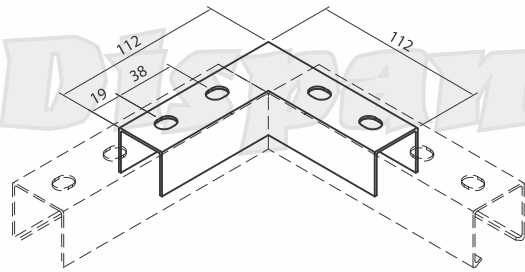

Emenda interna "T" - DP521

Internal channel joinder "T"

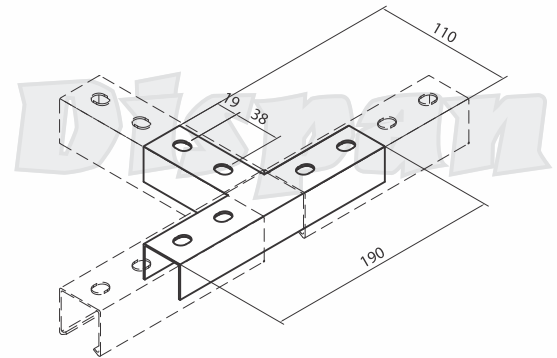

Emenda interna "X" - DP522

Internal channel joinder "X"

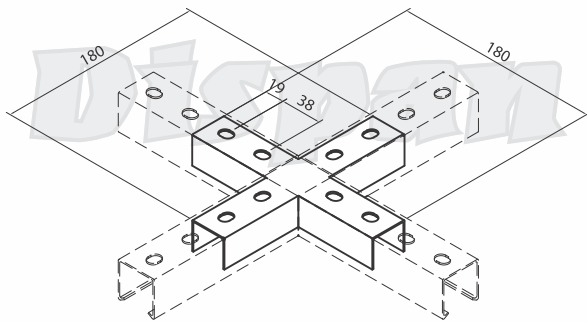

Suspensor p/ cabo 1/8" - DP523

Hanger clamp for steel cable 1/8"

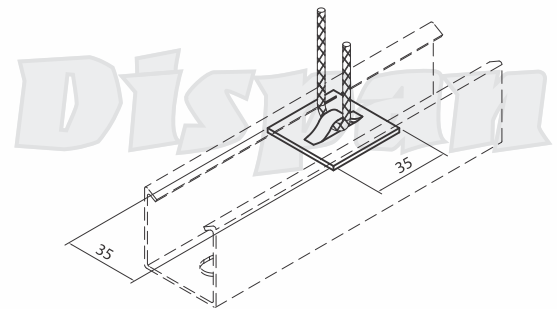

Carga máxima de 40 Kg.

Cantoneira "ZZ" p/ vergalhão - DP584

"ZZ" angle connector.

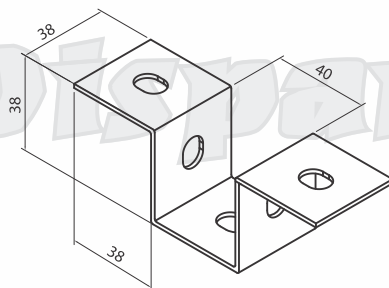

Carga máxima de 250 Kg.

Suporte p/ cabo de aço - DP525

Steel cable support.

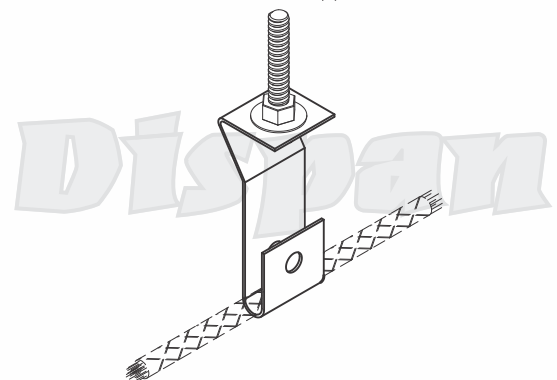

Carga máxima de 80 Kg.

Gancho curto p/ luminária - DP526

Short clamp for fixture.

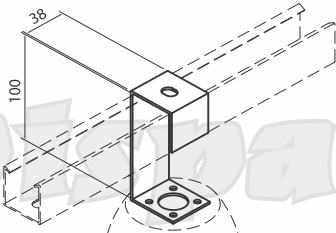

Carga máxima de 60 Kg.
Para perfilados de 38x38 mm.

Gancho longo p/ luminária - DP527

Long clamp for fixture.

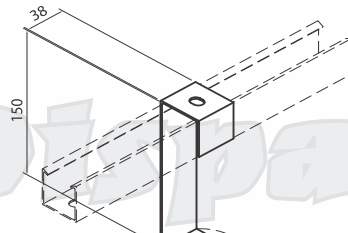

Carga máxima de 60 Kg.
Para perfilados de 38x38 mm.

Gancho curto p/ perfilado 38X38 mm DP528

Short clamp for channel.

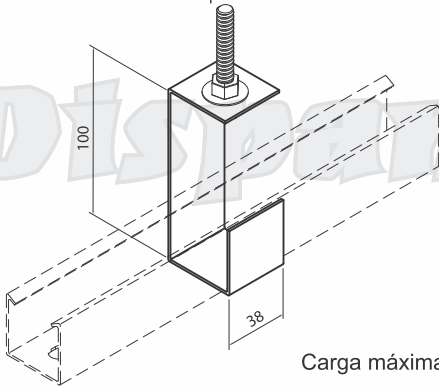

Carga máxima de 70 Kg.

Gancho longo p/ perfilado 38X38 mm DP529

Long clamp for channel.

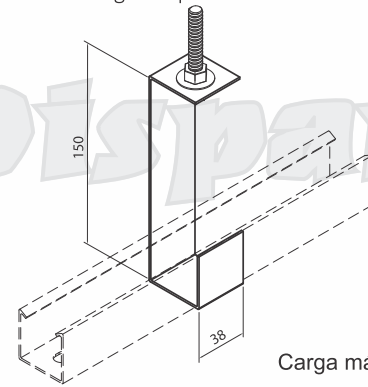

Carga máxima de 70 Kg.

Base p/ ligação em painel - DP530

Panel adapter.

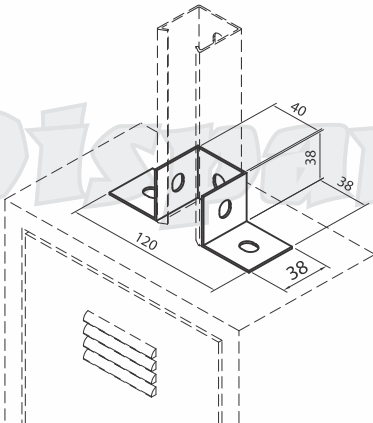

Saída superior p/ eletroduto - DP531

Upper outlet for conduit.

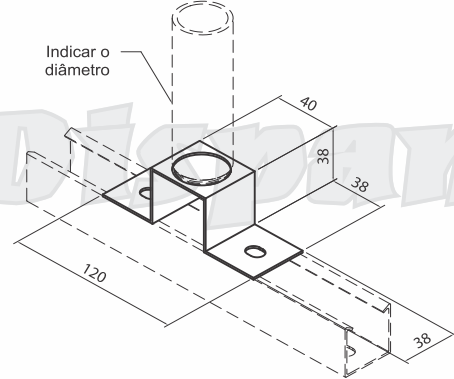

* Disponíveis para os tubos Ø 1/2", 3/4" e 1".

Saída lateral dupla p/ eletroduto - DP532

Lateral double outlet for conduit.

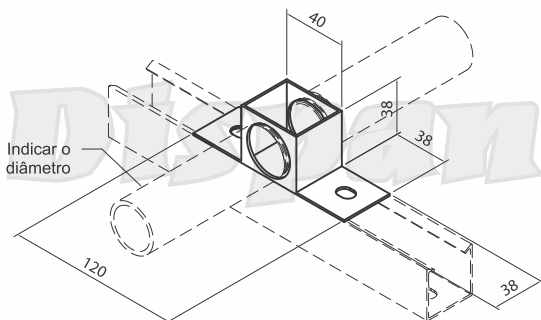

* Disponíveis para os tubos Ø 1/2", 3/4" e 1".

Saída simples p/ eletroduto - DP533

Lateral outlet for conduit.

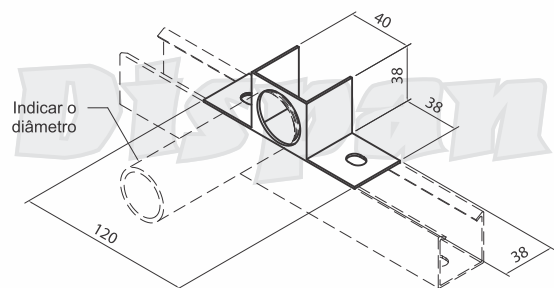

* Disponíveis para os tubos Ø 1/2", 3/4" e 1".

Saída final p/ eletroduto - DP534

End outlet conduit.

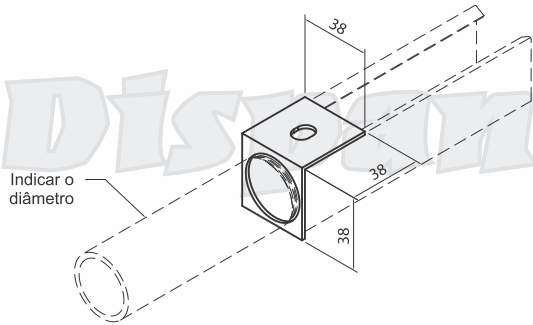

* Disponíveis para os tubos Ø 1/2", 3/4" e 1".

Arruela adaptadora - DP535

Saddle type washer.

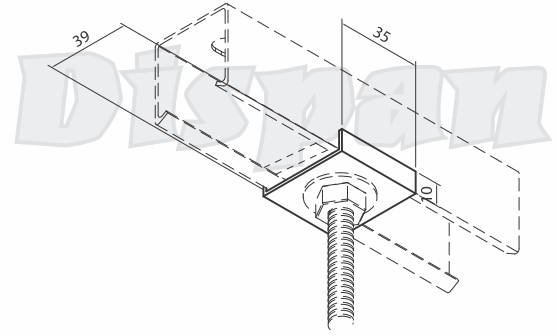

Caixa p/ tomada em perfilado - DP536

Channel box for electric outlets.

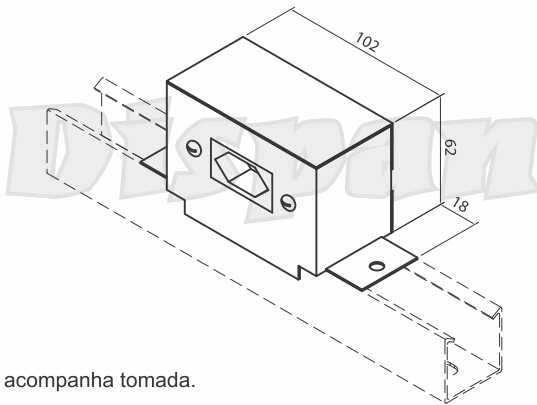

* Não acompanha tomada.

Channel box for electric outlets.

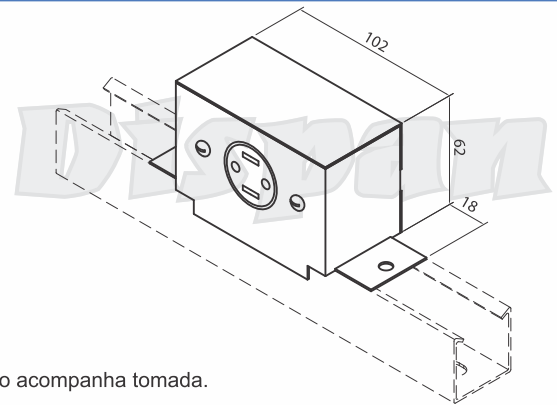

* Não acompanha tomada.

Caixa de ligação p/ perfilado - DP537

Channel box.

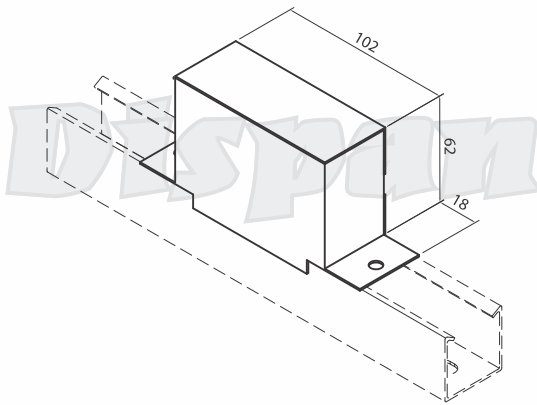

Grampo "C" - DP538

Beam clamp "C"

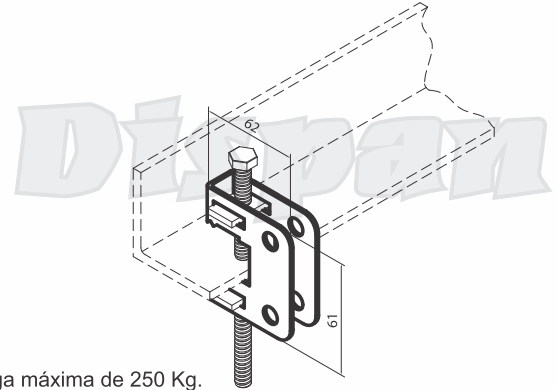

Carga máxima de 250 Kg.

Presilha p/ grampo "C" - DP539

Beam clamp "C"

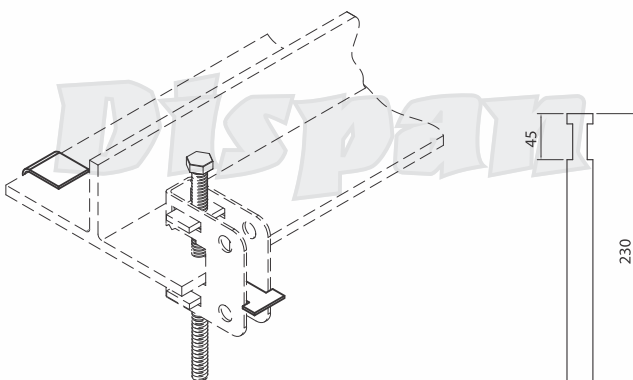

Balancim p/ grampo "C" - DP540

Swing connector for beam clamp.

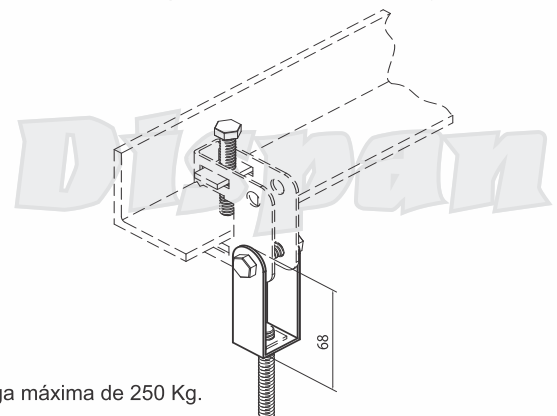

Carga máxima de 250 Kg.

Cabo de aço diâmetro 1/8" - DP541

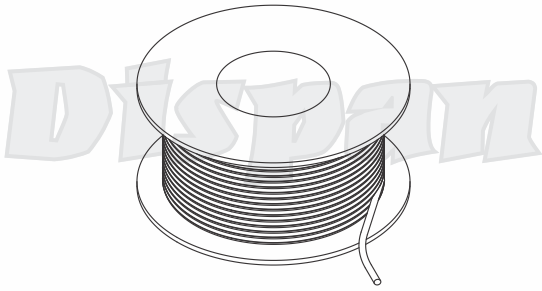

* Disponíveis nas bitolas de 1/8" e 3/16".

Base interna c/ 1 furo - DP542

Internal base 1- hole.

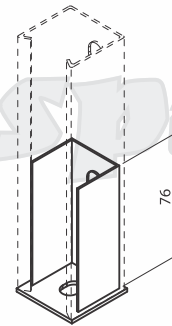

Base interna c/ 4 furos - DP543

Internal base 4- holes.

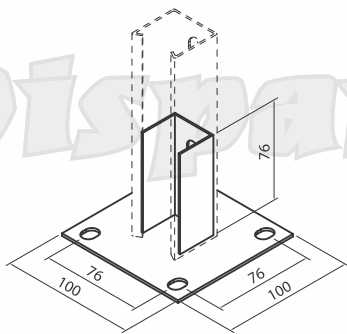

Base externa c/ 4 furos - DP544

External base 4- holes.

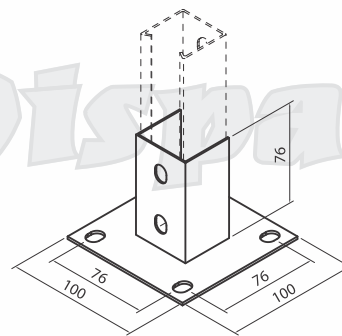

Caixa de derivação com tampa.

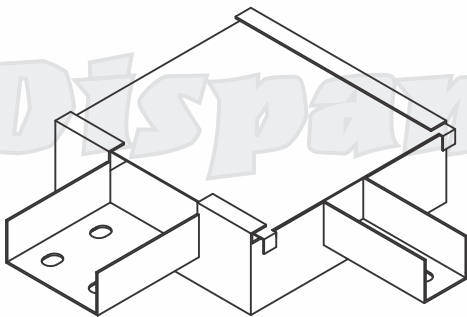

Caixa de derivação "L" p/ perfilado 38x76 mm c/ saída p/ perfilado 38x38 mm à direita - DP546D

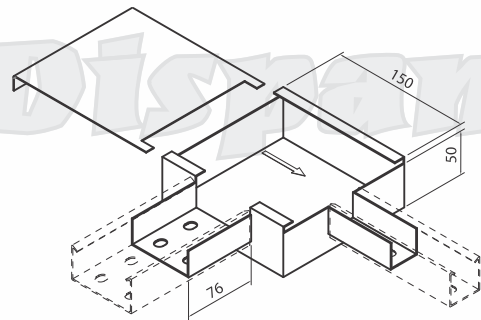

Caixa de derivação "L" p/ perfilado 38x76 mm c/ saída p/ perfilado 38x38 mm à esquerda - DP546E

"L" right junction box 76x38 mm.

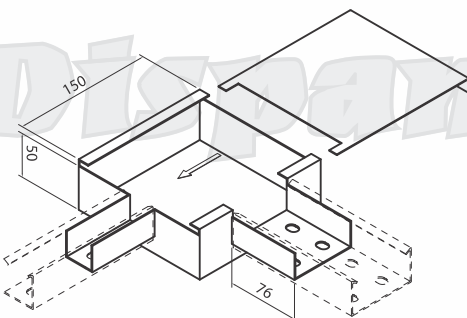

Caixa de derivação "T" p/ perfilado 76x38 mm c/ saída p/ perfilado 38x38 mm - DP547

"T" junction box 76x38 mm.

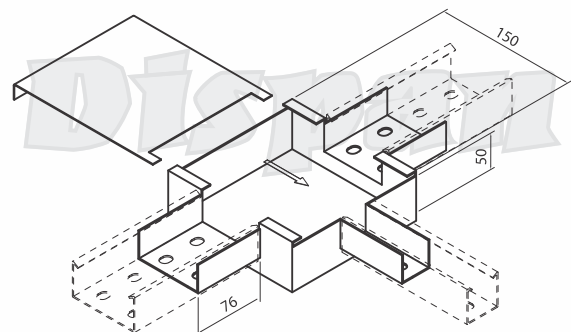

Caixa de derivação "I" para perfilado 38x38 mm - DP548

"I" junction box.

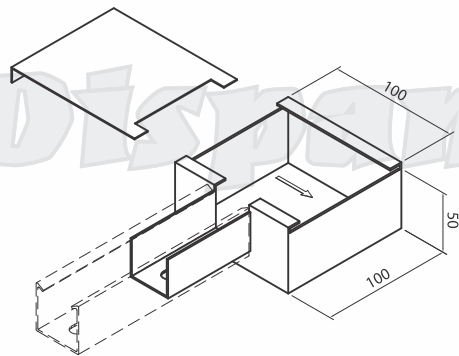

Caixa de derivação "C" para perfilado 38x38 mm - DP549

"C" junction box.

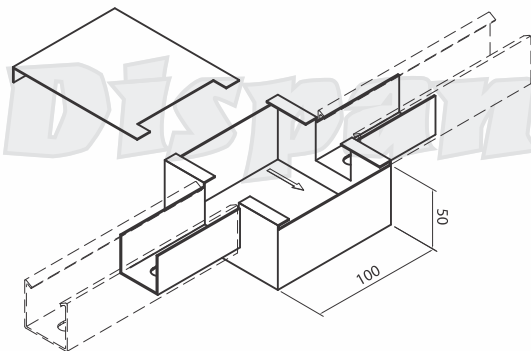

Caixa de derivação "L" para perfilado 38x38 mm - DP550

"L" junction box.

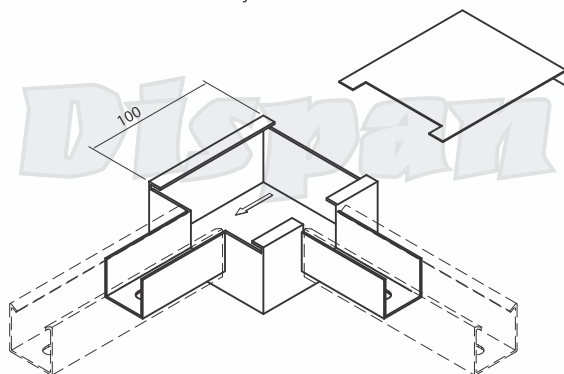

Caixa de derivação "T" para perfilado 38x38 mm - DP551

"T" junction box.

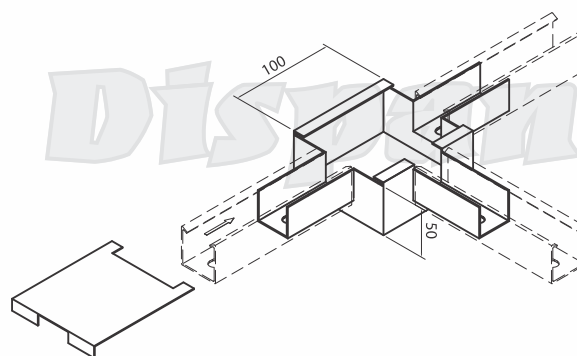

Caixa de derivação "X" para perfilado 38x38 mm - DP552

"X" junction box.

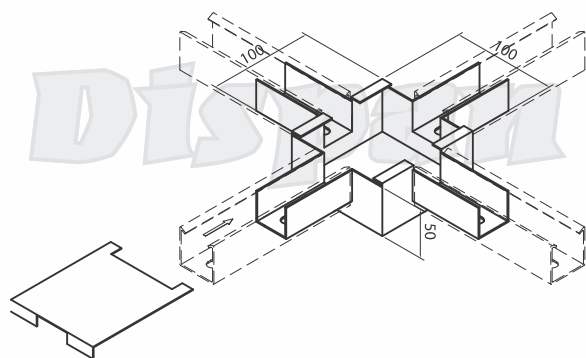

Caixa de derivação "I" c/ saída inferior para perfilado 38x38 mm - DP553

"I" junction box with bottom outlet.

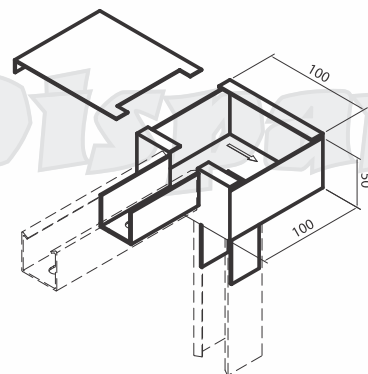

Base externa dupla c/ 4 furos - DP554

Double lower base 4- holes.

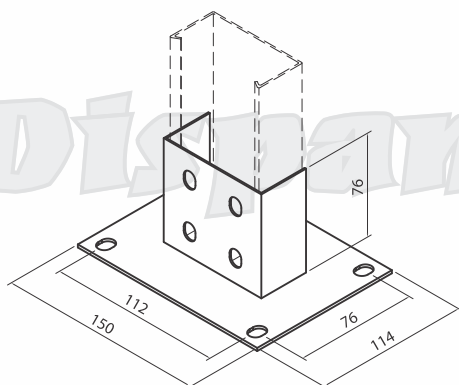

Base dupla p/ ligação em painel - DP555

Double panel adapter.

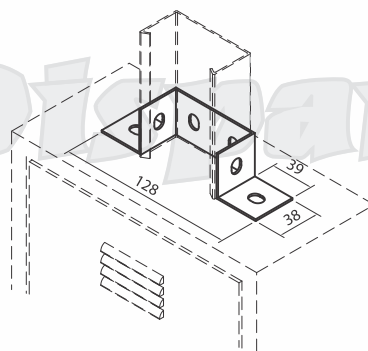

Emenda externa "I" 38x76 mm - DP556

"I" external junction.

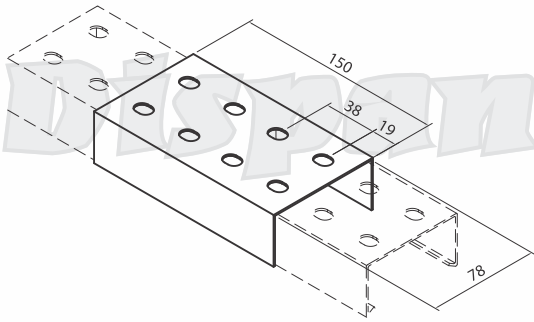

Emenda interna "I" 38x76 mm - DP557

"I" internal junction.

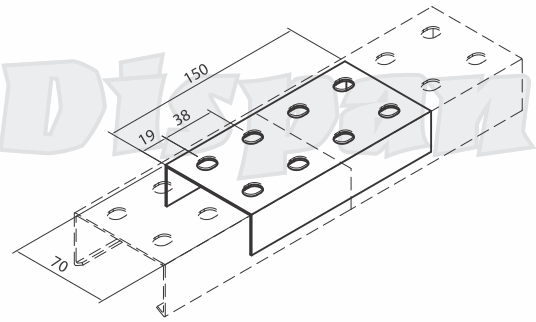

Emenda interna "L" 38x76 mm - DP558

"L" internal junction.

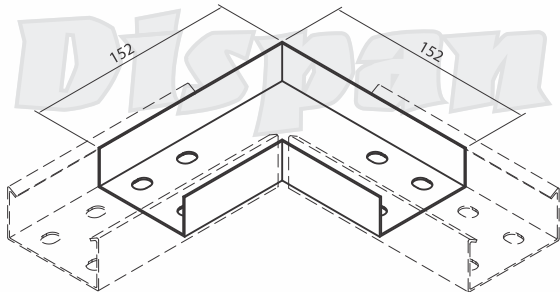

Emenda interna "T" 38x76 mm - DP559

"T" internal junction.

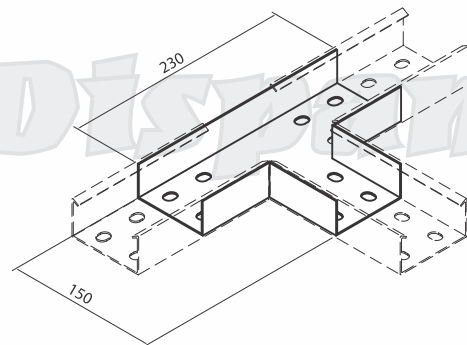

Emenda interna "X" 38x76 mm - DP560

"X" internal junction.

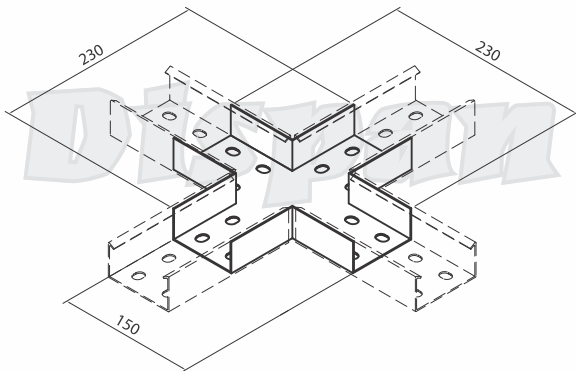

Gancho curto p/ perfilado 38x76 mm - DP561

Hanger for double channel.

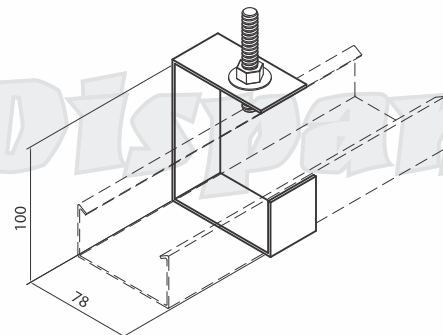

Carga máxima de 70 Kg.

Gancho longo p/ perfilado 38x76 mm - DP562

Long hanger for double channel.

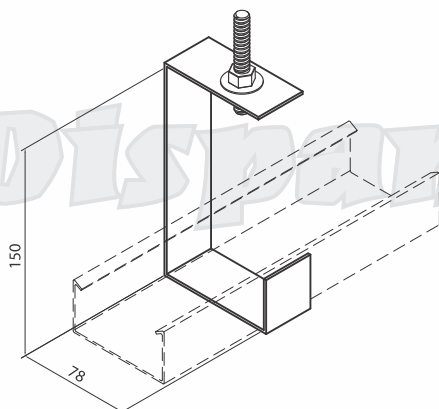

Redução concêntrica 76x38 mm - DP563

76x38 mm box channel reducer.

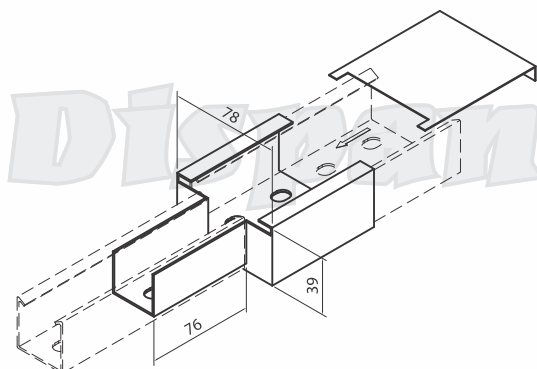

Caixa de derivação "I" para perfilado 38x76 mm - DP564

"I" junction box for double channels.

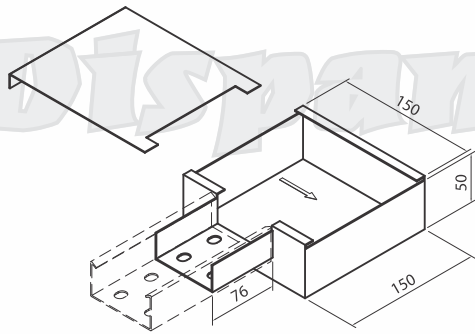

Caixa de derivação "C" para perfilado 38x76 mm - DP565

"C" junction box for double channels.

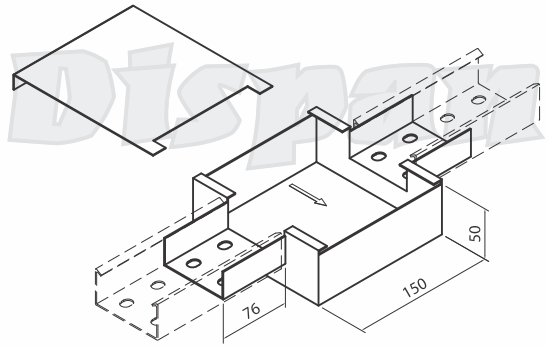

Caixa de derivação "L" para perfilado 38x76 mm - DP566

"L" junction box for double channels.

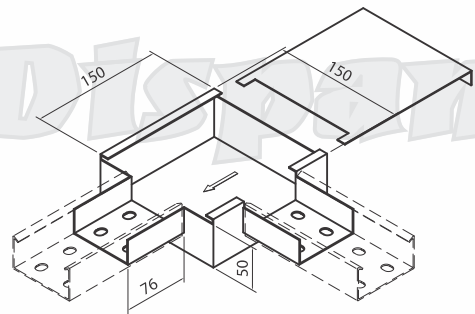

Caixa de derivação "T" para perfilado 38x76 mm - DP567

"T" junction box for double channels.

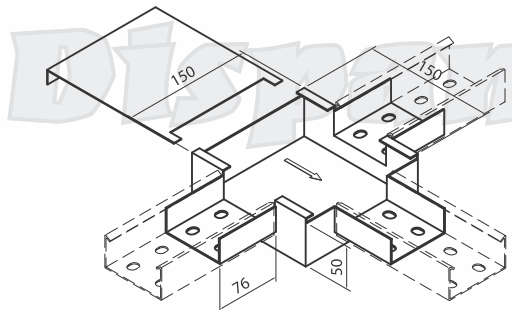

Caixa de derivação "X" para perfilado 38x76 mm - DP568

"X" junction box for double channels.

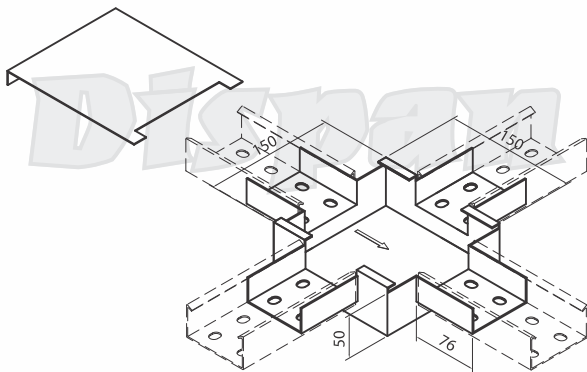

Caixa de derivação "C" c/ saída inferior para perfilado 38x76 mm - DP569

"C" junction box for double channels with one bottom outlet.

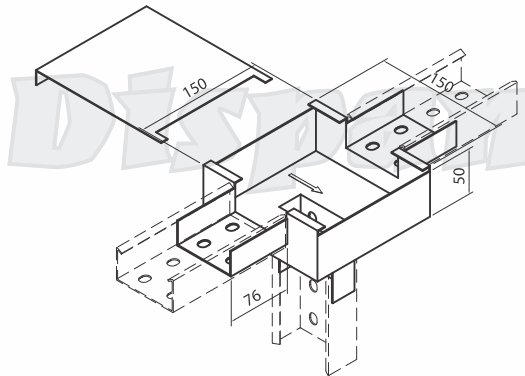

Caixa de derivação "I" c/ saída inferior para perfilado 38 x 76 mm - DP570

"I" junction box four double channel with one bottom outlet.

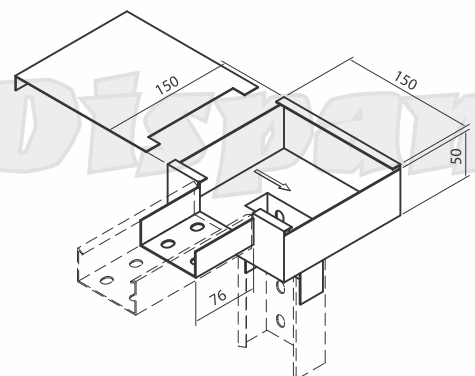

Caixa de derivação "C" c/ saída inferior 38x38 mm - DP571

"C" junction box for 76 mm and bottom outlet for 38 channel.

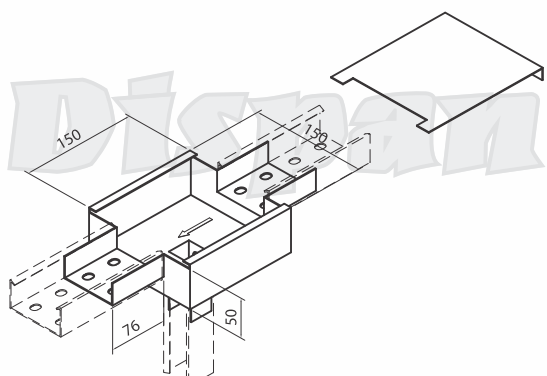

Cantoneira c/ 2 furos simples - DP572

Two hole angle connector.

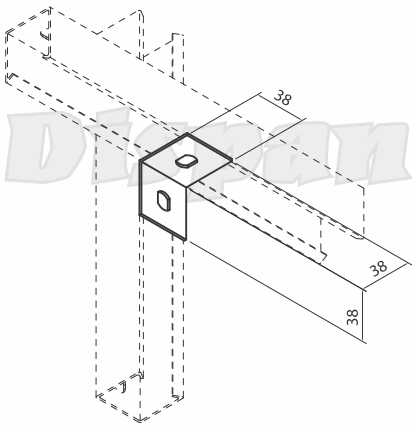

Cantoneira c/ 3 furos simples - DP573

Three hole angle connector.

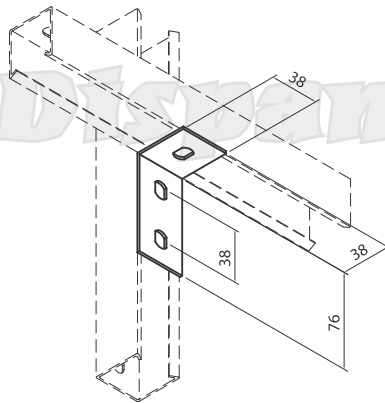

Cantoneira c/ 4 furos simples - DP574

Four hole angle connector.

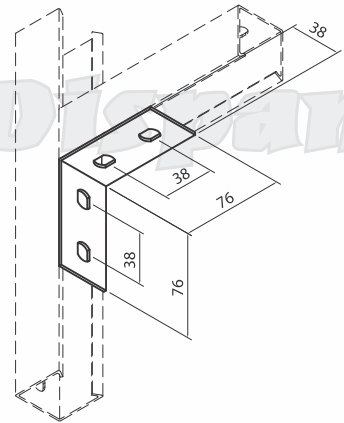

Cantoneira c/ 5 furos simples - DP575

Five hole angle connector.

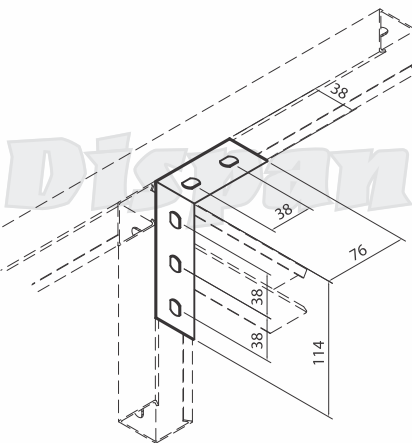

Cantoneira c/ 6 furos simples - DP576

Six hole angle connector.

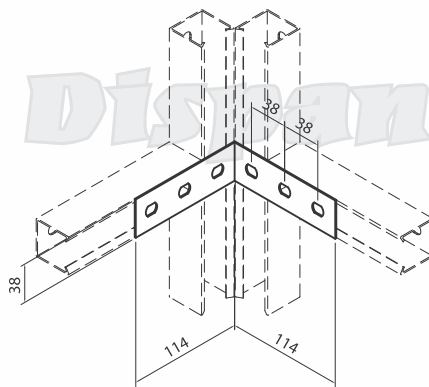

Cantoneira c/ 1 furo e 1 rasgo - DP577

One hole- one slot angle connector.

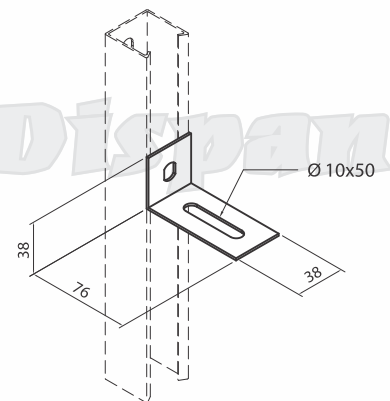

Cantoneira c/ 2 furos e 1 rasgo - DP578

Two hole- one slot angle connector.

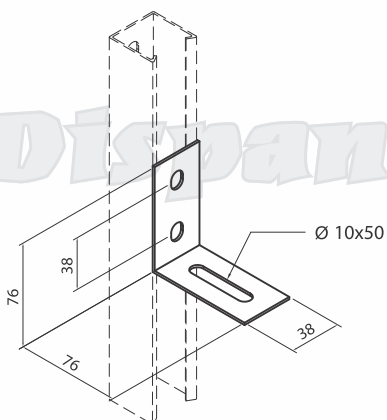

Cantoneira c/ 2 furos reforçada - DP579

reinforced two hole angle connector.

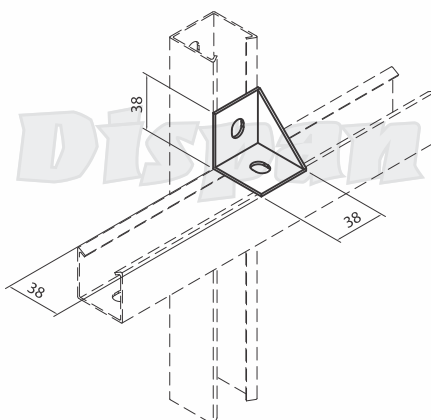

Cantoneira c/ 4 furos reforçada - DP580

Reinforced four hole angle connector.

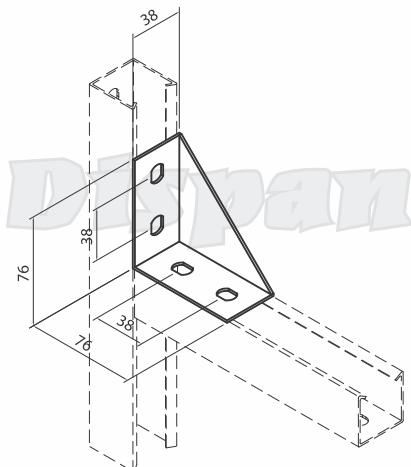

Cantoneira "Z" meia - DP581

Z- support for 19 deep channel.

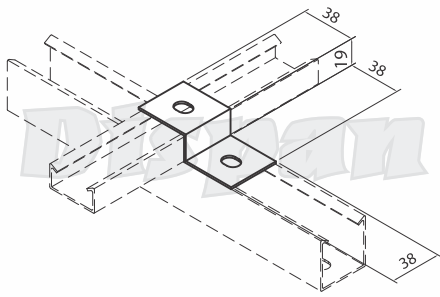

Cantoneira "Z" - DP582

Z- support for 38 deep channel.

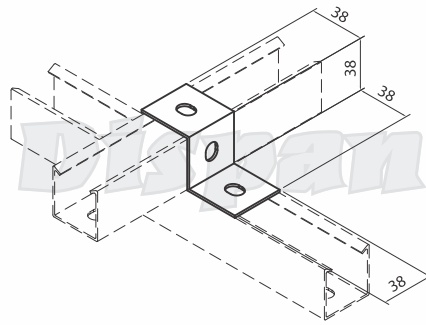

Cantoneira "ZZ" meia - DP583

ZZ- support for 19 deep channel.

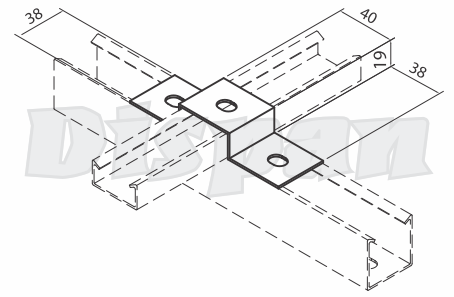

Cantoneira "ZZ" - DP584

ZZ- support for 38 deep channel.

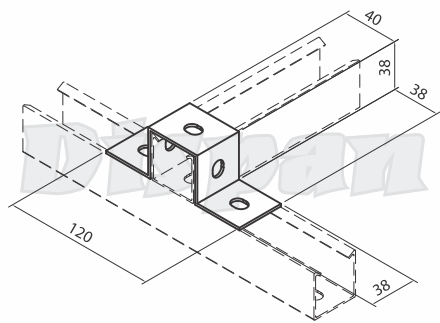

Cantoneira "ZZ" dupla vertical - DP585

ZZ- support for two vertical 38 deep channel.

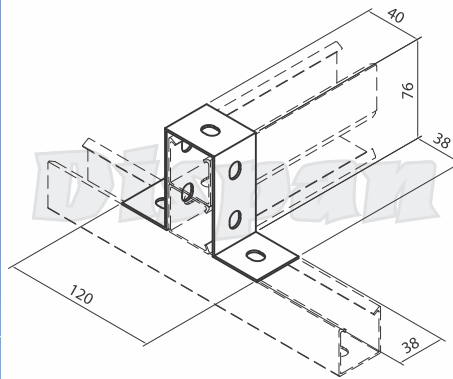

Cantoneira "ZZ" dupla horizontal - DP586

ZZ- support for two horizontal 38 deep channel.

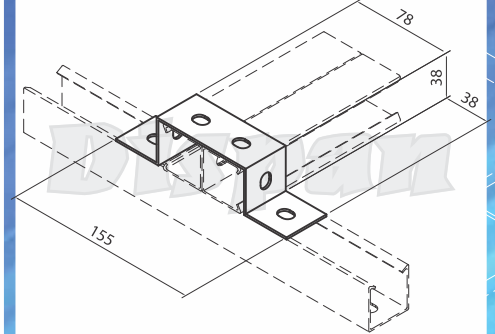

Distanciador c/ 1 furo - DP587

Separator 1 hole.

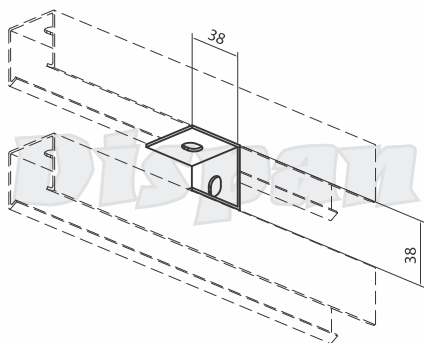

Distanciador c/ 2 furos - DP588

Separator 2 hole.

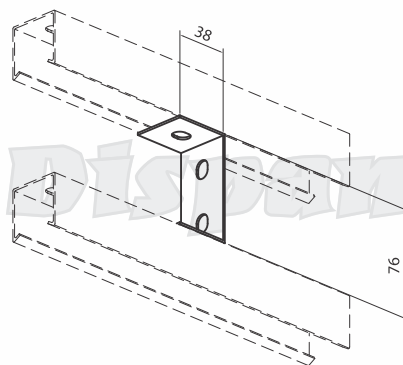

Distanciador c/ 3 furos - DP589

Separator 3 hole.

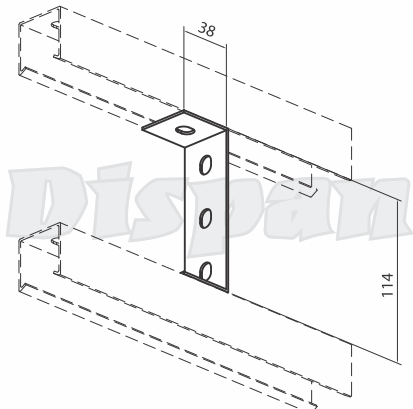

Distanciador c/ 4 furos - DP590

Separator 4 holes.

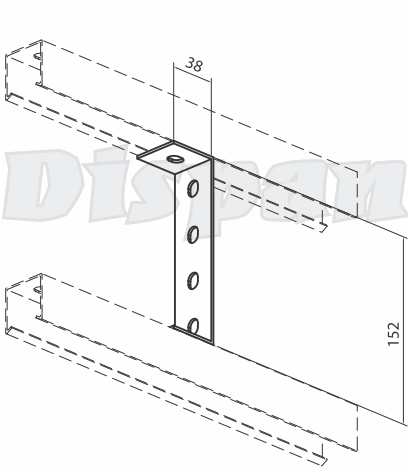

Junção plana "L" - DP591

"L" plate connector.

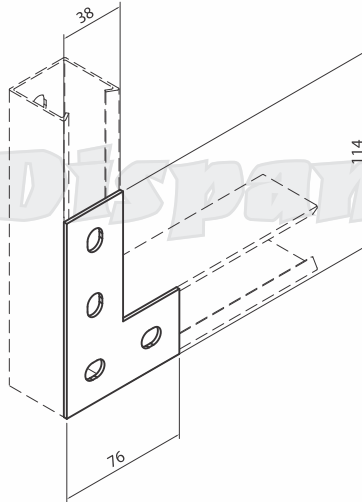

Junção plana "T" - DP592

"T" plate connector.

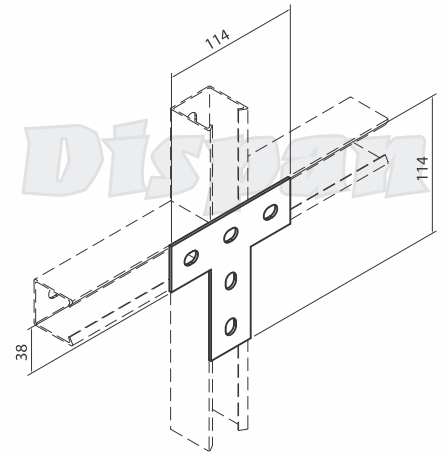

Junção plana "L" reforçada - DP593

Four hole "L"- plate connector.

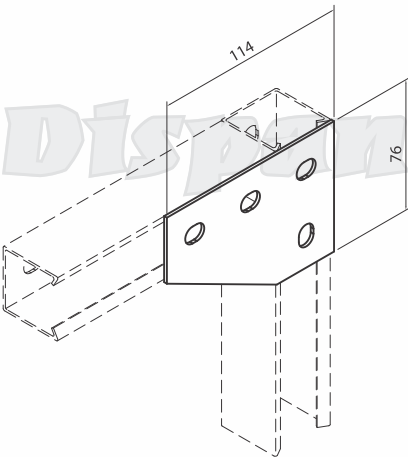

Junção plana "T" reforçada - DP594

Five hole "T"- plate connector.

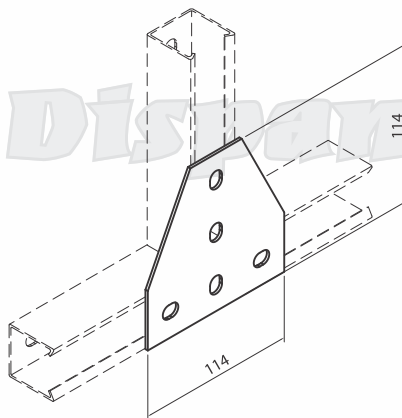

Junção plana "X" reforçada - DP595

Seven hole "X"- plate connector.

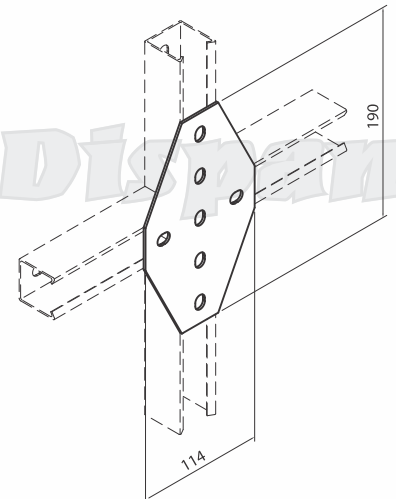

Tala simples c/ 1 furo - DP596

One hole plate connector.

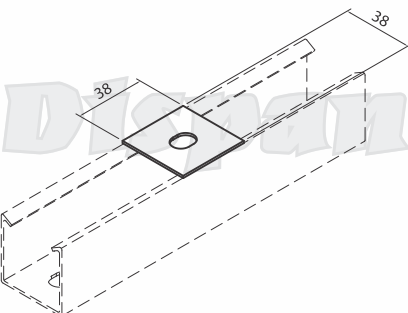

Tala simples c/ 2 furos - DP597

Two hole plate connector.

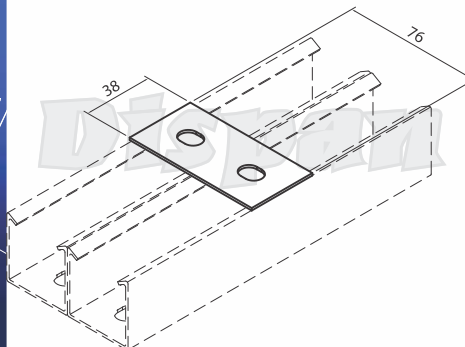

Tala simples c/ 3 furos - DP598

Three hole plate connector.

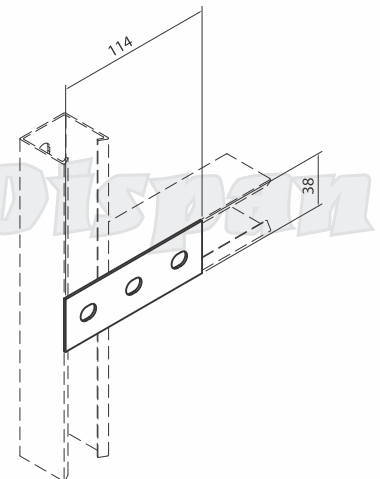

Tala simples c/ 4 furos - DP599

Four hole plate connector.

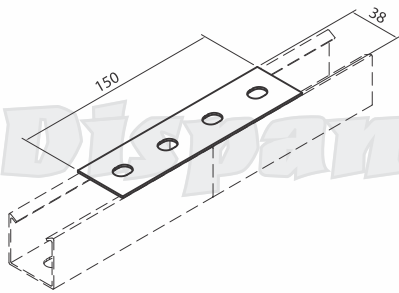

Tala simples c/ 5 furos - DP600

Five hole plate connector.

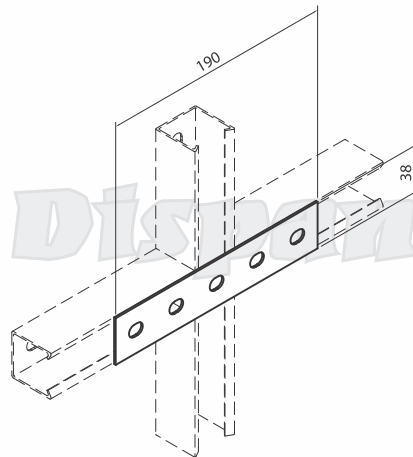

Tala simples c/ 6 furos - DP601

Six hole plate connector.

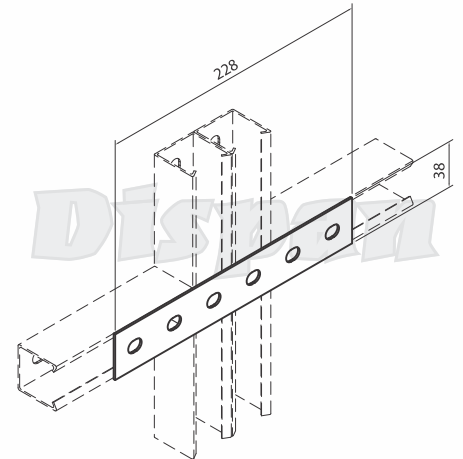

Curva vertical interna 90° p/ perfilado 38x38 mm - DP602

90° internal vertical bend for channel 38x38 mm.

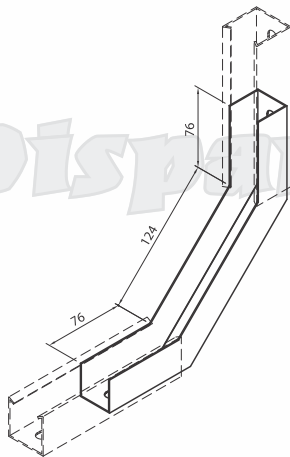

Curva horizontal 90° p/ perfilado 38x38 mm - DP603

90° horizontal bend for channel 38x38 mm.

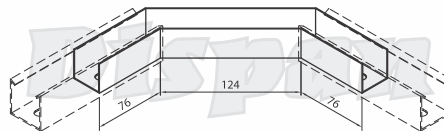

Curva vertical externa 90° p/ perfilado 38x38 mm - DP604

90° external vertical bend for channel 38x38 mm.

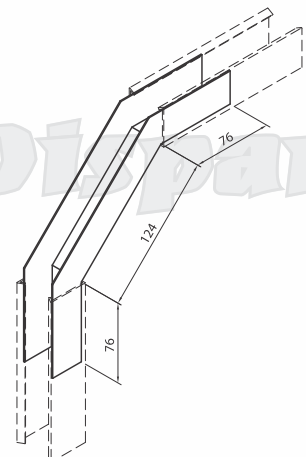

Curva de inversão 90° p/ perfilado 38x38 mm - DP605

90° reversal vertical bend for channel 38x38 mm.

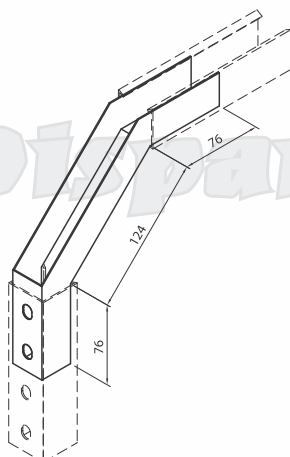

Desnível vertical p/ perfilado 38x38 mm - DP606

Vertical crossover for channel 38x38 mm.

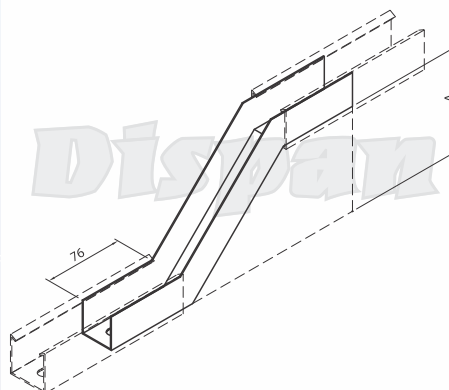

Obs: Indicar cota A.

Desvio horizontal à direita p/ perfilado 38x38 mm - DP607-D

Right horizontal crossover for channel 38x38 mm.

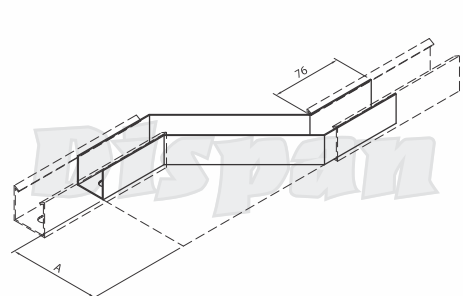

Obs: Indicar cota A.

**Desvio horizontal à esquerda
p/ perfilado 38x38 mm - DP607-E**

Lift horizontal crossover for
channel 38x38 mm.

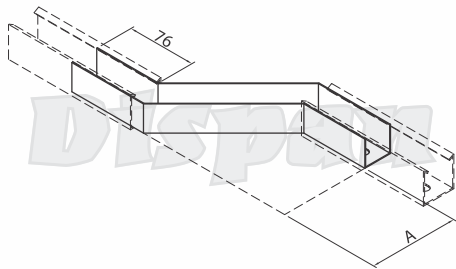

Obs: Indicar cota A.

**Curva vertical interna 45° p/
perfilado 38x38 mm - DP641**

45° internal vertical bend for
channel 38x38 mm.

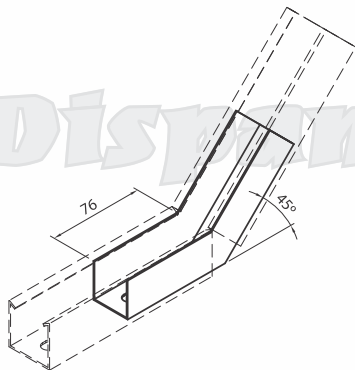

**Curva horizontal 45° p/
perfilado 38x38 mm - DP642**

45° horizontal bend for
channel 38x38 mm.

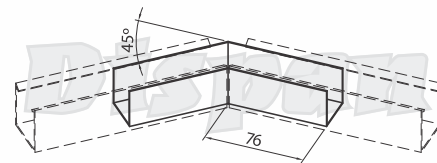

**Curva vertical externa 45° p/
perfilado 38x38 mm - DP643**

45° external vertical bend for
channel 38x38 mm.

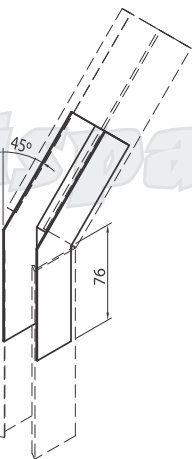

**Curva vertical interna 90° p/
perfilado 38x76 mm - DP644**

90° internal vertical bend for
channel 38x38 mm.

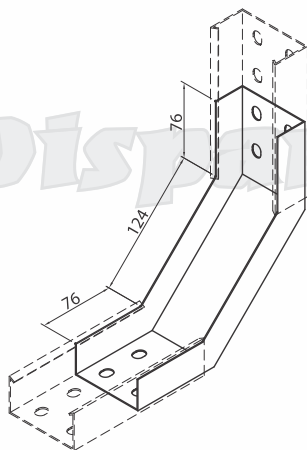

**Curva horizontal 90° p/
perfilado 38x76 mm - DP645**

90° horizontal bend for
channel 38x38 mm.

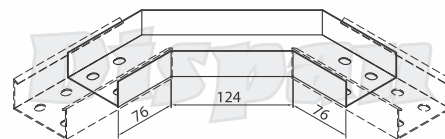

**Curva vertical externa 90° p/
perfilado 38x76 mm - DP646**

90° external bend for
channel 38x38 mm.

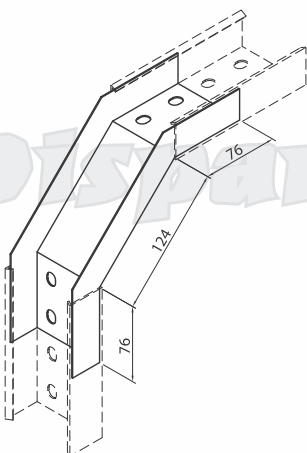

**Curva de inversão 90° p/
perfilado 38x76 mm - DP647**

90° reversal vertical bend for
channel 38x38 mm.

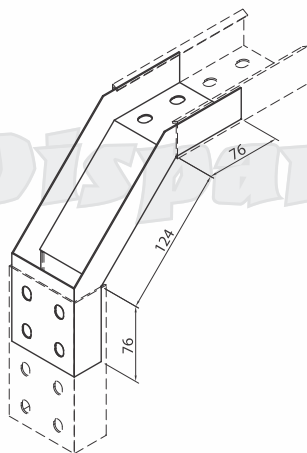

**Desnível vertical p/
perfilado 38x76 mm - DP648**

Vertical crossover for channel 38x38 mm.

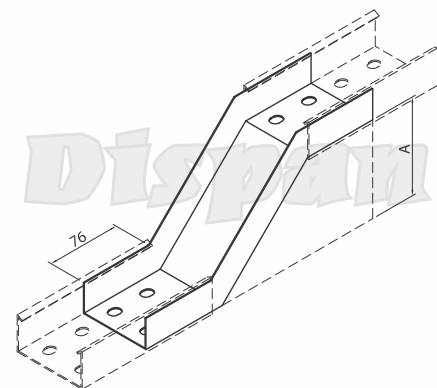

Obs: Indicar cota A.

Desvio horizontal à direita p/ perfilado 38x76 mm - DP649

Right horizontal crossover for channel 38x76 mm.

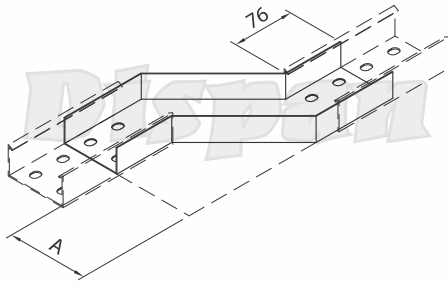

Obs: Indicar cota A.

Desvio horizontal à esquerda p/ perfilado 38x76 mm - DP650

Left horizontal crossover for channel 38x76 mm.

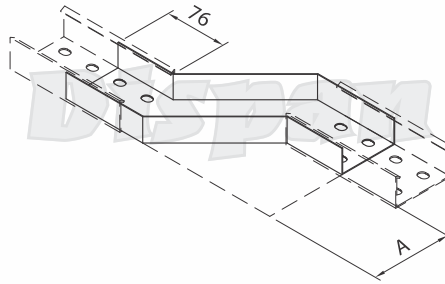

Obs: Indicar cota A.

Curva vertical interna 45° p/ perfilado 38x76 mm - DP651

45° internal vertical bend for channel 38x76 mm.

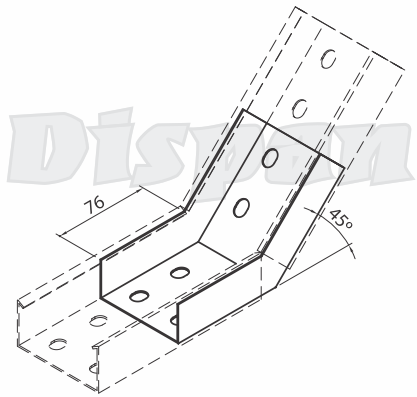

Curva horizontal 45° p/ perfilado 38x76 mm - DP652

45° horizontal bend for channel 38x76 mm.

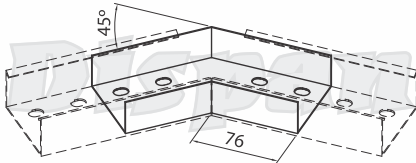

Curva vertical externa 45° p/ perfilado 38x76 mm - DP653

45° external vertical bend for channel 38x76 mm.

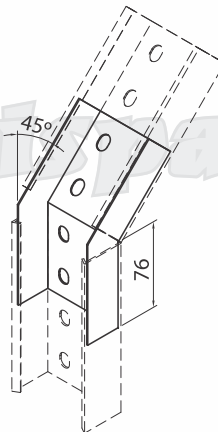

Vergalhão rosca total - DP608

Continuous threaded rod.



Tabela de carga	
Diametros do vergalhão	Carga máxima
Vergalhão 1/4"	Kg 450
Vergalhão 5/16"	Kg 600
Vergalhão 3/8"	Kg 920
Vergalhão 1/2"	Kg 1250

Parafuso olhal - DP609

Eyelet screw.

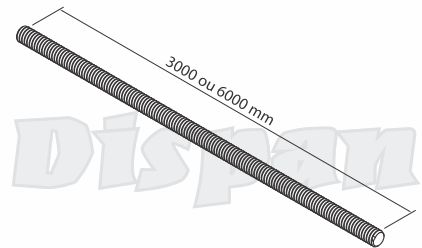

Tabela de carga.	
Diametros de paraf. olhal	Carga máxima
Olhal de 1/4"	Kg 90
Olhal de 3/8"	Kg 150

Prolongador para vergalhão - DP610

Hanger rod extension.

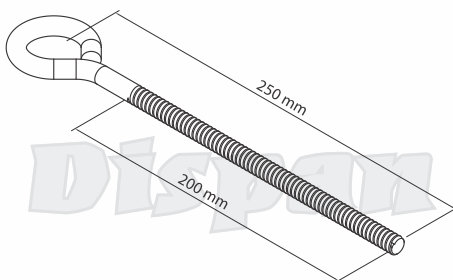

Tabela de carga.	
Diametros do prolongador	Carga máxima
Prolongador 1/4"	Kg 450
Prolongador 5/16"	Kg 600
Prolongador 3/8"	Kg 920
Prolongador 1/2"	Kg 1250

Grapa fixa 3/8" - DP611

Guide saddle.

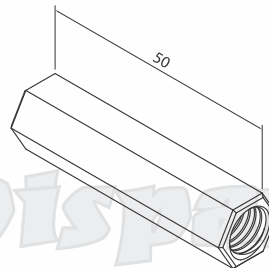
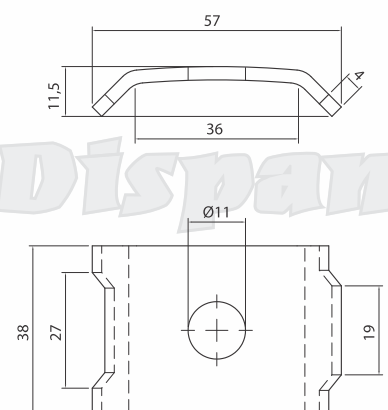

Fixação de leito com grapa fixa 3/8".

ening with guide saddle.

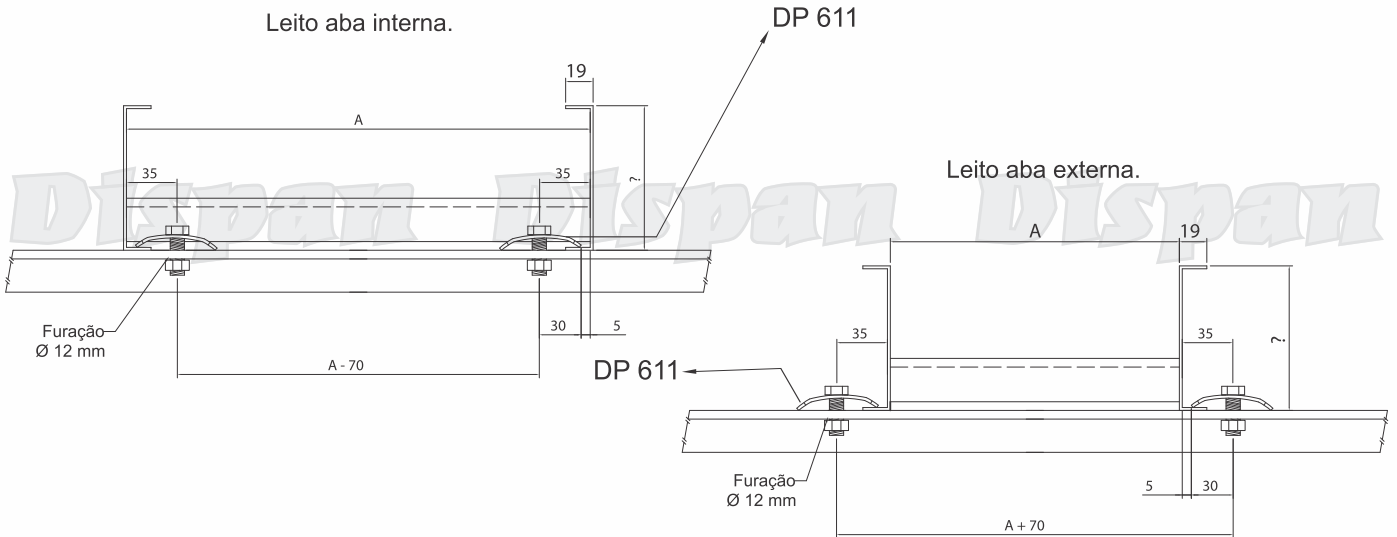

Parafuso cabeça lentilha c/ fenda - DP612

"Lentil"- type head screw.

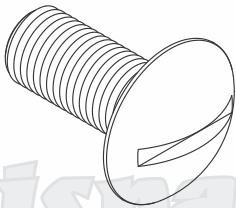

Rosca	Comprimento
1/4"	1/2"
1/4"	5/8"
1/4"	3/4"
5/16"	3/4"
3/8"	3/4"

Parafuso cabeça lentilha auto - travante - DP613

"Lentil"- type head screw.

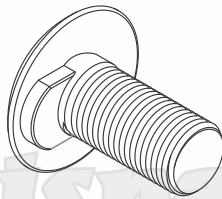

Rosca	Comprimento
1/4"	1/2"
1/4"	5/8"
1/4"	3/4"
5/16"	3/4"
3/8"	3/4"

Parafuso cabeça sextavada - DP614

Hex screw.

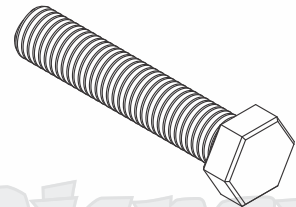

Rosca	Comprimento
1/4"	1/2"
	3/4"
5/16"	1"
	1.1/2"
3/8"	2"
	2.1/2"
	3"

Parafuso cabeça redonda c/ fenda - DP615

Round head screw

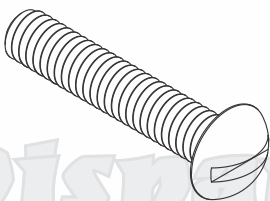

Rosca	Comprimento
1/4"	1/2"
	3/4"
5/16"	1"
	1.1/2"
3/8"	2"
	2.1/2"
	3"

Parafuso cabeça redonda c/ fenda rosca soberba p/ bucha - DP616

Round head screw with conical thread.

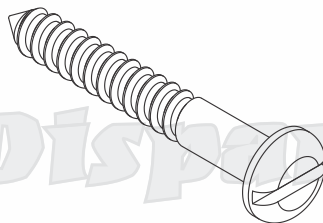

Bucha	Dimensões
S - 6	3,9 x 32
S - 8	4,8 x 38
S - 10	6,3 x 50

Parafuso cabeça sextavada soberba p/ bucha - DP617

Hex head screw with conical thread.

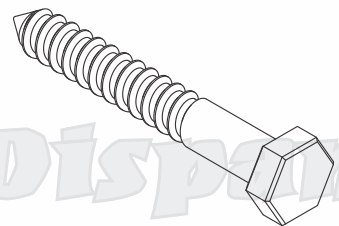

Bucha	Dimensões
S - 8	4,8 x 32
S - 10	1/4" x 50
S - 12	5/16" x 50

Porca sextavada - DP618

Nut.

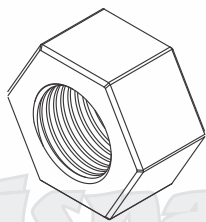

Rosca
1/4"
5/16"
3/8"
1/2"

Arruela lisa - DP619

Plain washer.

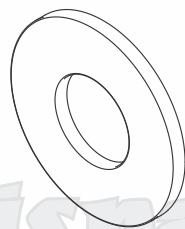

Rosca
1/4"
5/16"
3/8"
1/2"

Arruela de pressão - DP620

Lock washer.

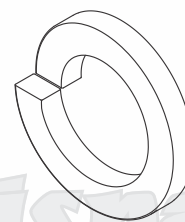

Rosca
1/4"
5/16"
3/8"
1/2"

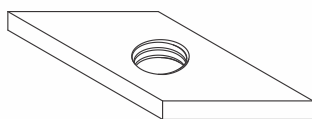
Porca losangular s/ mola DP621

Rosca	Carga máx. em Kg.
1/4"	120 Kg
5/16"	210 Kg
3/8"	450 Kg
1/2"	500 Kg

Porca losangular c/ mola - DP622

Lozengular nut with spring.

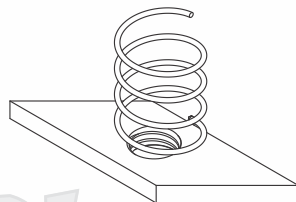

Rosca	Carga máx. em Kg.
1/4"	120 Kg
5/16"	210 Kg
3/8"	450 Kg
1/2"	500 Kg

Porca losangular c/ pino - DP623

Lozengular stud nut.

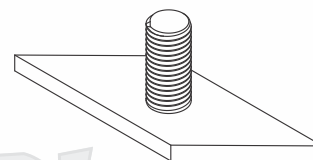

Rosca	Carga máx. em Kg.
1/4"	120 Kg
5/16"	210 Kg
3/8"	450 Kg
1/2"	500 Kg

Bucha de nylon - DP624N

Nylon cinchanchor for concrete insert.

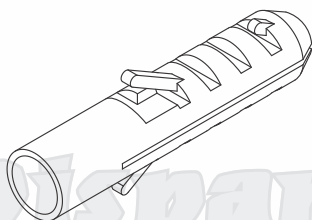

Rosca	Ø Broca p/ furo	Carga máx. em Kg.
S - 6	1/4" - 6 mm	25 Kg
S - 8	5/16" - 8 mm	50 Kg
S - 8	3/8" - 10 mm	75 Kg
S - 8	1/2" - 12 mm	100 Kg

Bucha de plástico - DP624P

Plastic cinchanchor for concrete insert.

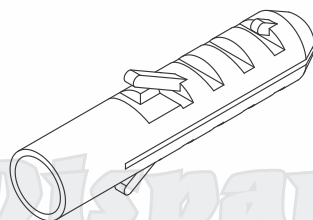

Rosca	Ø Broca p/ furo	Carga máx. em Kg.
S - 6	1/4" - 6 mm	16 Kg
S - 8	5/16" - 8 mm	35 Kg
S - 8	3/8" - 10 mm	60 Kg
S - 8	1/2" - 12 mm	80 Kg

Chumbador "CB" completo - DP625

Complete anchor bolt.

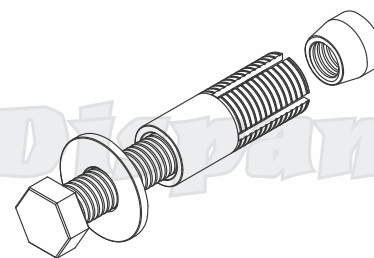

Rosca	Compri. s/ paraf.	Broca	Carga máx. em Kg.
1/4"	35 mm	10 mm	1300 Kg
5/16"	38 mm	12 mm	1550 Kg
3/8"	40 mm	14 mm	2100 Kg

Chumbador "CB" sem parafuso - DP625CJ

Anchor bolt with internal thread.

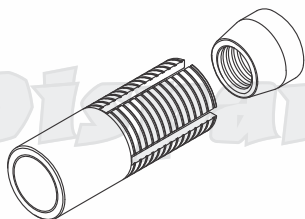

Rosca	Compri. s/ paraf.	Broca	Carga máx. em Kg.
1/4"	35 mm	10 mm	1300 Kg
5/16"	38 mm	12 mm	1550 Kg
3/8"	40 mm	14 mm	2100 Kg

Chumbador "URX" - DP626

Anchor bolt with external thread.

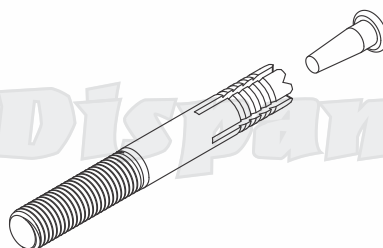

Rosca	Compri. s/ paraf.	Broca	Carga máx. em Kg.
1/4"	56 mm	20 mm	900 Kg
5/16"	60 mm	25 mm	1100 Kg
3/8"	75 mm	30 mm	1800 Kg

Batedor "URX" - DP627

Beater "URX".

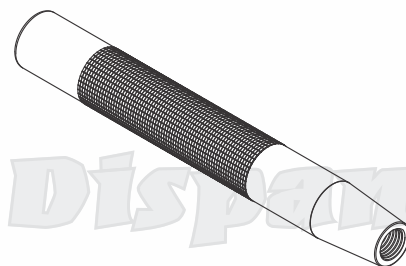

Rosca
1/4"
5/16"
3/8"

Chumbador "UR" - DP628

Internal-thread anchor bolt.

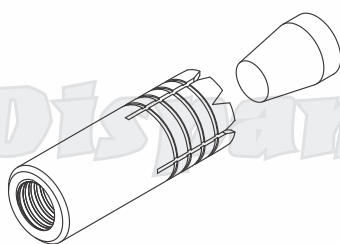

Rosca	Compri. s/ paraf.	Broca	Carga máx. em Kg.
1/4"	35 mm	10 mm	900 Kg
5/16"	35 mm	13 mm	1400 Kg
3/8"	40 mm	14 mm	1800 Kg

Batedor "UR" - DP629

Beater "UR".

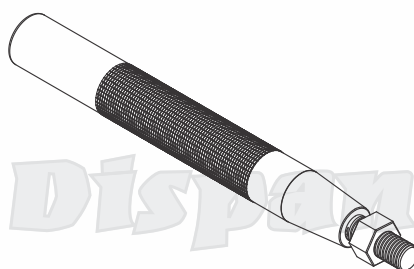

Rosca
1/4"
5/16"
3/8"

Grampo - DP524

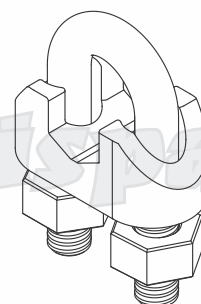

Disponível para cabo de aço 1/8" e 3/16".

Braçadeira "D" com cunha - DP630

"D" pipe clamp

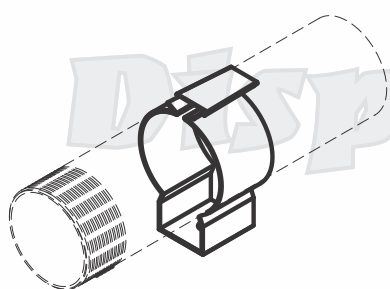

Referência	Ø Nominal
630 - 1	1/2"
630 - 2	3/4"
630 - 3	1"
630 - 4	1.1/4"
630 - 5	1.1/2"
630 - 6	2"
630 - 7	2.1/2"
630 - 8	3"
630 - 9	3.1/2"
630 - 10	4"

Braçadeira "U" perfil com parafuso - DP631

"U" pipe clamp

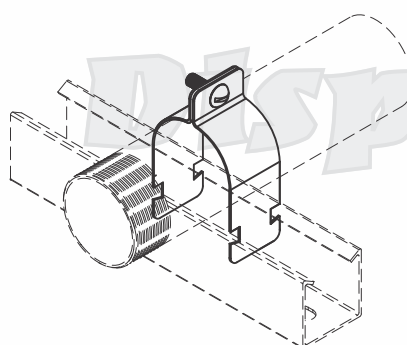

Referência	Ø Nominal
631 - 1	1/2"
631 - 2	3/4"
631 - 3	1"
631 - 4	1.1/4"
631 - 5	1.1/2"
631 - 6	2"
631 - 7	2.1/2"
631 - 8	3"
631 - 9	3.1/2"
631 - 10	4"

Braçadeira omêga - DP632

Omega clamp.

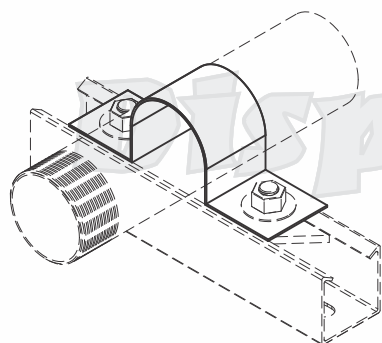

Referência	Ø Nominal
632 - 1	1/2"
632 - 2	3/4"
632 - 3	1"
632 - 4	1.1/4"
632 - 5	1.1/2"
632 - 6	2"
632 - 7	2.1/2"
632 - 8	3"
632 - 9	3.1/2"
632 - 10	4"

Braçadeira unha - DP633

Nail clamp.

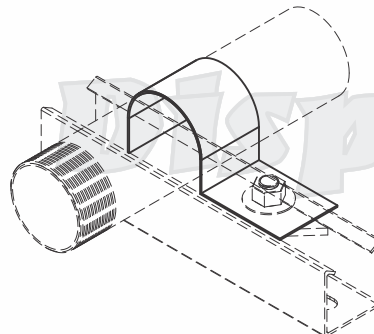

Referência	Ø Nominal
633 - 1	1/2"
633 - 2	3/4"
633 - 3	1"
633 - 4	1.1/4"
633 - 5	1.1/2"
633 - 6	2"
633 - 7	2.1/2"
633 - 8	3"
633 - 9	3.1/2"
633 - 10	4"

Braçadeira "U" de vergalhão - DP634

"U" clamp.

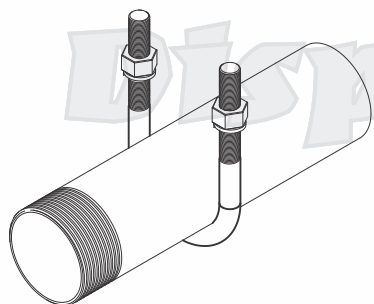

Referência	Ø Nominal	Carga Máx.
634 - 1	1/2"	200 Kg
634 - 2	3/4"	350 Kg
634 - 3	1"	350 Kg
634 - 4	1.1/4"	350 Kg
634 - 5	1.1/2"	350 Kg
634 - 6	2"	350 Kg
634 - 7	2.1/2"	500 Kg
634 - 8	3"	500 Kg
634 - 9	3.1/2"	500 Kg
634 - 10	4"	500 Kg
634 - 11	5"	500 Kg
634 - 12	6"	500 Kg
634 - 13	8"	900 Kg
634 - 14	10"	900 Kg
634 - 15	12"	900 Kg

Braçadeira econômica - DP635

Bend hanger economic-type.

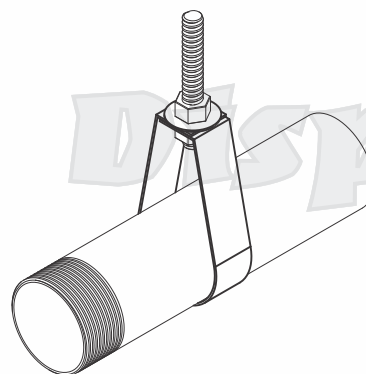

Referência	Ø Nominal	Carga Máx.
635 - 1	1/2"	200 Kg
635 - 2	3/4"	200 Kg
635 - 3	1"	200 Kg
635 - 4	1.1/4"	200 Kg
635 - 5	1.1/2"	200 Kg
635 - 6	2"	250 Kg
635 - 7	2.1/2"	250 Kg
635 - 8	3"	250 Kg
635 - 9	3.1/2"	250 Kg
635 - 10	4"	250 Kg
635 - 11	5"	300 Kg
635 - 12	6"	300 Kg
635 - 13	8"	300 Kg

Braçadeira união horizontal - DP636

Adjustable hanger horizontal type.

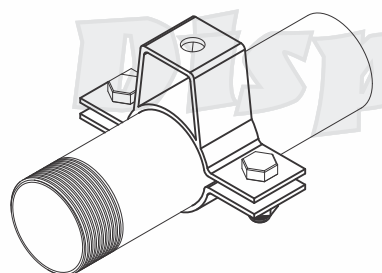

Referência	Ø Nominal	Carga Máx.
636 - 1	1/2"	200 Kg
636 - 2	3/4"	200 Kg
636 - 3	1"	200 Kg
636 - 4	1.1/4"	250 Kg
636 - 5	1.1/2"	250 Kg
636 - 6	2"	250 Kg
636 - 7	2.1/2"	250 Kg
636 - 8	3"	250 Kg
636 - 9	3.1/2"	250 Kg
636 - 10	4"	250 Kg
636 - 11	5"	300 Kg
636 - 12	6"	300 Kg
636 - 13	8"	300 Kg
636 - 14	10"	300 Kg
636 - 15	12"	300 Kg

Braçadeira união vertical - DP637

Adjustable hanger vertical type.

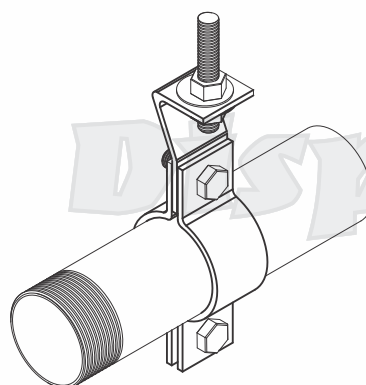

Referência	Ø Nominal	Carga Máx.
637 - 1	3/4"	200 Kg
637 - 2	1/2"	200 Kg
637 - 3	1"	200 Kg
637 - 4	1.1/4"	250 Kg
637 - 5	1.1/2"	250 Kg
637 - 6	2"	250 Kg
637 - 7	2.1/2"	250 Kg
637 - 8	3"	250 Kg
637 - 9	3.1/2"	250 Kg
637 - 10	4"	250 Kg
637 - 11	5"	300 Kg
637 - 12	6"	300 Kg
637 - 13	8"	300 Kg
637 - 14	10"	300 Kg
637 - 15	12"	300 Kg

Braçadeira vertical - DP638

Vertical type.

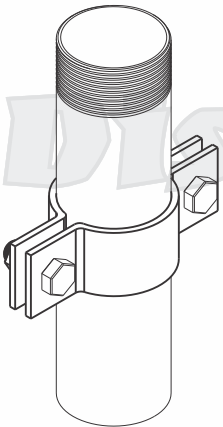

Referência	Ø Nominal	Carga Máx.
638 - 1	3/4"	200 Kg
638 - 2	1/2"	200 Kg
638 - 3	1"	200 Kg
638 - 4	1.1/4"	250 Kg
638 - 5	1.1/2"	250 Kg
638 - 6	2"	250 Kg
638 - 7	2.1/2"	250 Kg
638 - 8	3"	250 Kg
638 - 9	3.1/2"	250 Kg
638 - 10	4"	250 Kg
638 - 11	5"	300 Kg
638 - 12	6"	300 Kg
631 - 13	8"	300 Kg
631 - 14	10"	300 Kg
631 - 15	12"	300 Kg

Grampo "C" 1/4" - DP639

Small beam clamp.

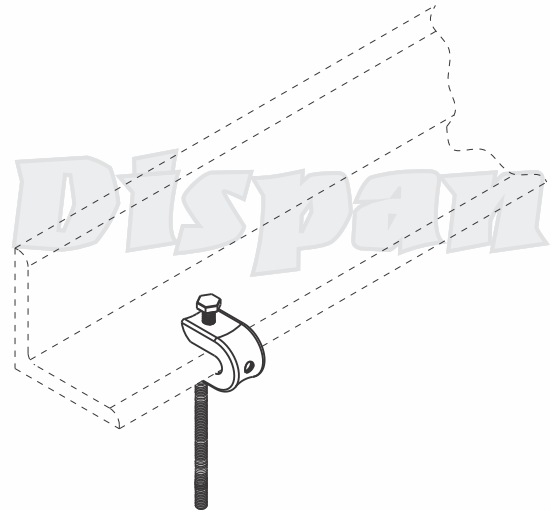

Suporte para eletroduto - DP640

Conduit support.

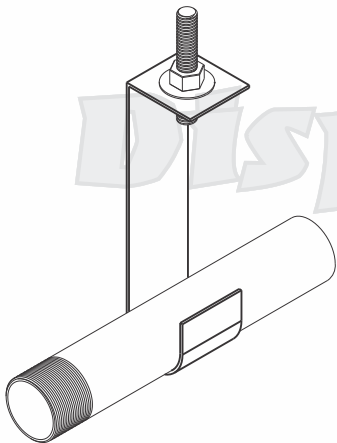

Referência	Ø Nominal	Carga Máx.
640 - 1	1/2"	60 Kg
640 - 2	3/4"	60 Kg
640 - 3	1"	60 Kg

Braçadeira "D" com parafuso - DP630P

"D" pipe clamp.

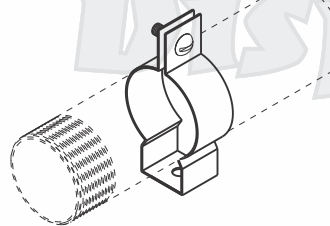

Referência	Ø Nominal
630 - 1	1/2"
630 - 2	3/4"
630 - 3	1"
630 - 4	1.1/4"
630 - 5	1.1/2"
630 - 6	2"
630 - 7	2.1/2"
630 - 8	3"
630 - 9	3.1/2"
630 - 10	4"



Demonstração de Suportação.

Typical applications.

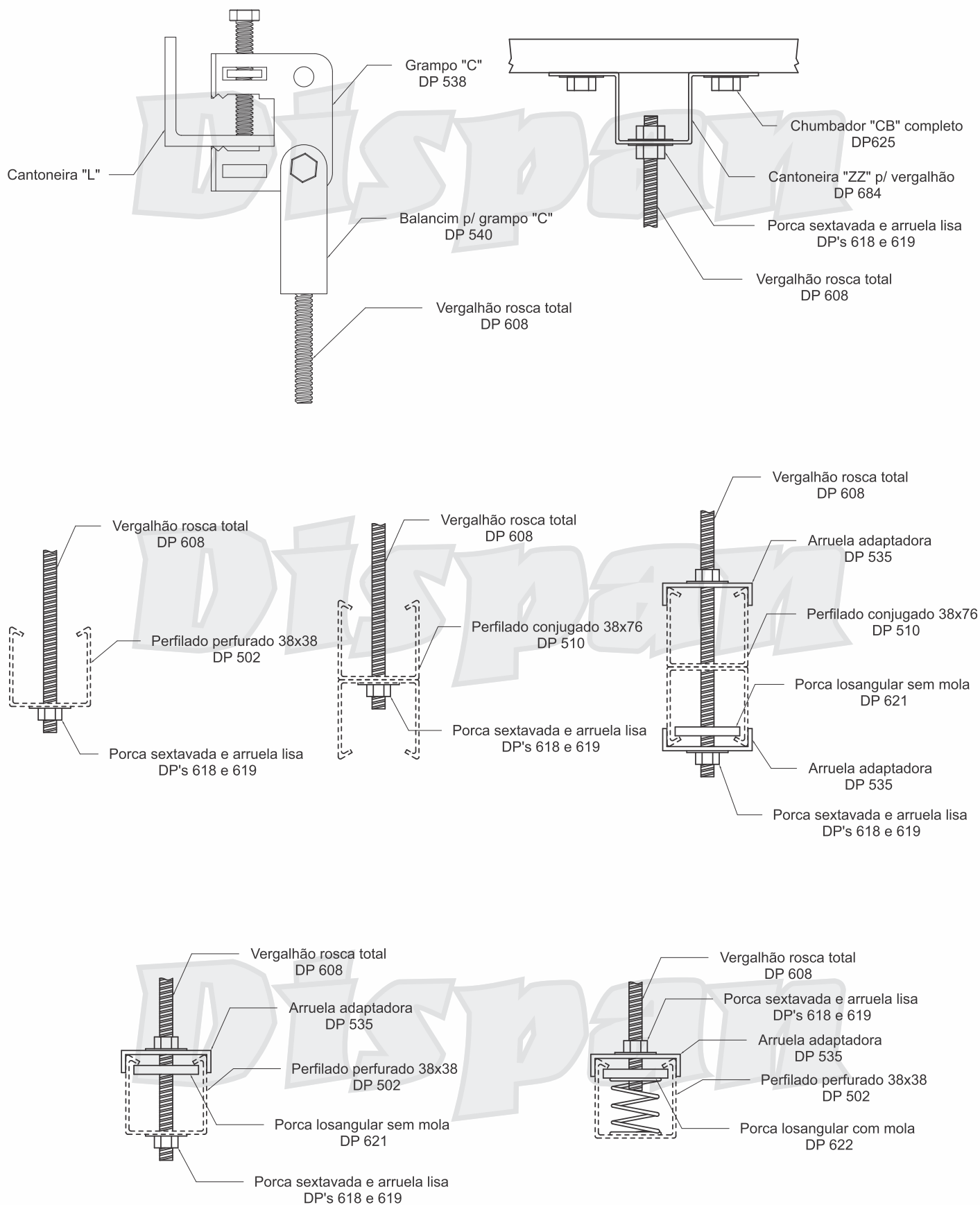



Aramados

Wire fittings

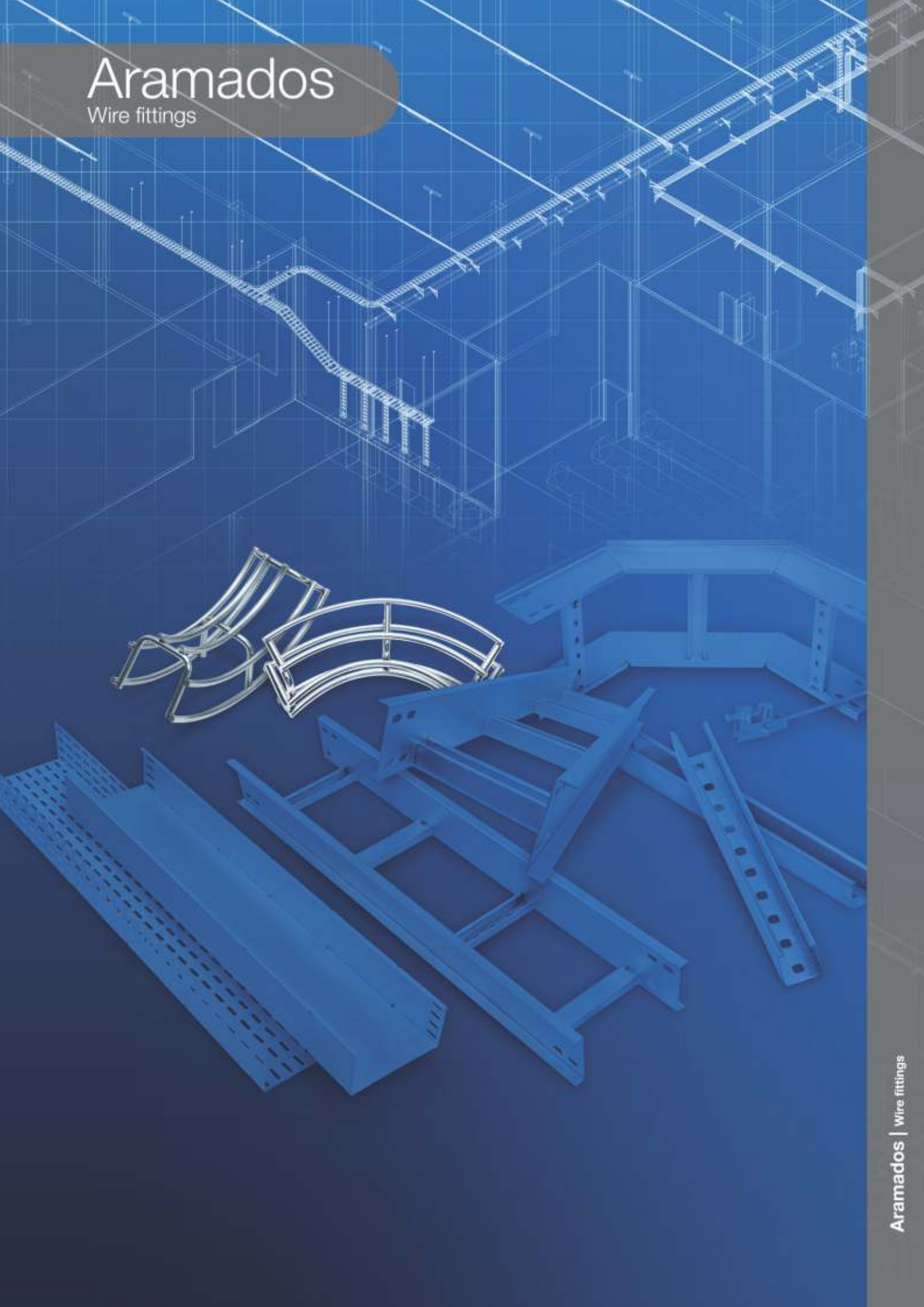

Como solicitar eletrocalha aramada

How to specify wire mesh cable tray.

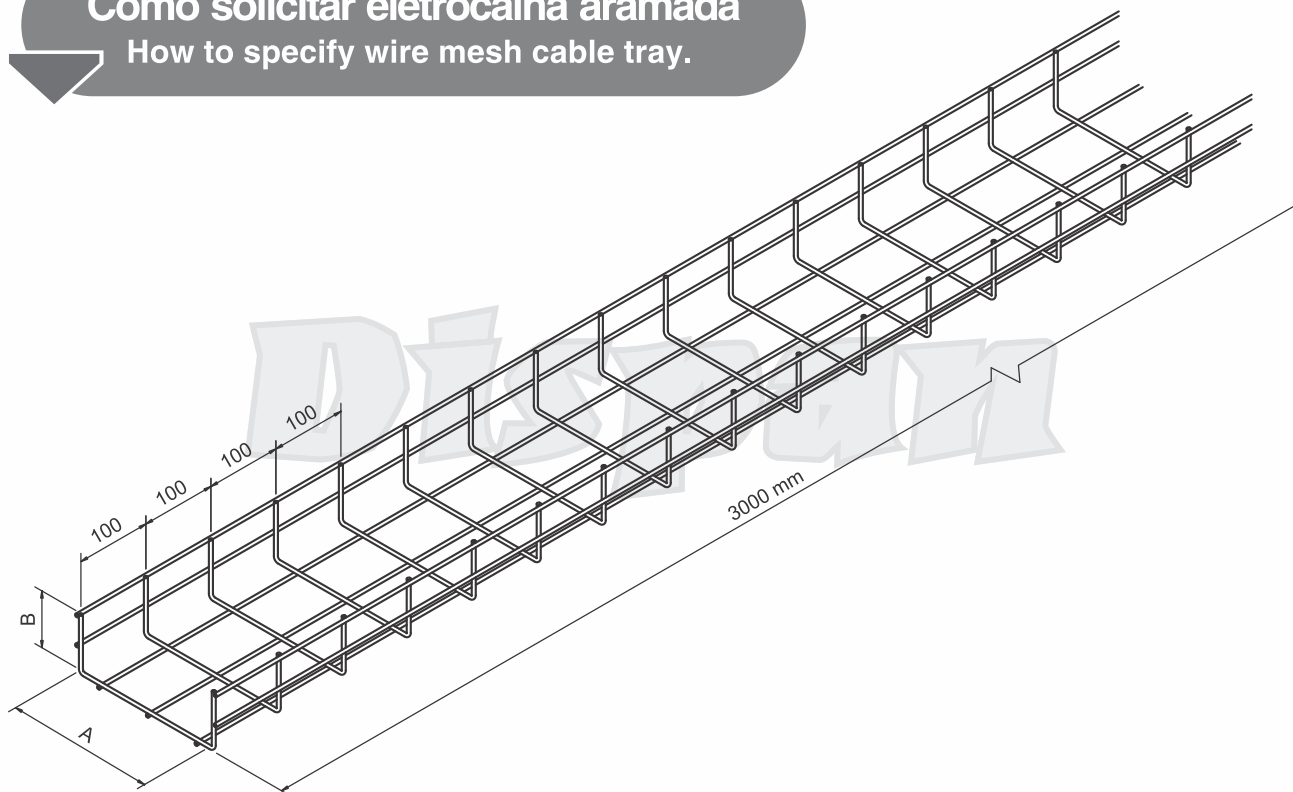

Exemplo:

Example

DP900 - AC - GF - 400/100 - 3/16"

Modelo da eletrocalha aramada.

Matéria-prima de fabricação.

Acabamento.

Largura / altura da eletrocalha.

Bitola do arame de construção da eletrocalha aramada.

DP900 - Eletrocalha aramada - Tipo leve

Matéria-prima base

AC - Aço carbono
AI - Aço inox

Acabamento aplicado na matéria-prima em base de aço carbono.

GF - Galvanizado à fogo por imersão
GE - Galvanizado eletrolítico
PT - Galvanizado e Pintado

Largura

400 - Largura da eletrocalha desejada (De 30mm a 1000mm)

Altura

100 - Altura da eletrocalha desejada (30mm / 50mm / 75mm / 100mm / 150mm)

Diâmetro da bitola dos arames.

3/16" - Bitola da eletrocalha aramada = Tipo Leve.

1/4" - Bitola da eletrocalha aramada = Tipo Pesado.

Descritivo técnico.

DP900 - Eletrocalha aramada leve, em aço carbono, galvanizado fogo, largura de 400 mm, com aba de 100 mm na bitola 3/16".

Montagem com conector curto ou reforçado.

Larguras - 50 à 75 mm = 2 Conectores.
100 à 200 mm = 3 Conectores.
300 à 1000 mm = 4 Conectores.

Nota - 1

Ocasionalmente podem ocorrer algumas distorções de medidas em nossas peças, por diversos fatores. Por este motivo damos uma tolerância de 5,0 mm entre as medidas mencionadas no catálogo e as peças reais. As peças de conexões entre as partes contêm furos oblongos para corrigir eventuais diferenças.

Leito Sanitário / Eletrocalha Aramada 3/16" Tipo Leve

Wire mesh cable tray 3/16" lightweight kind

DP 900

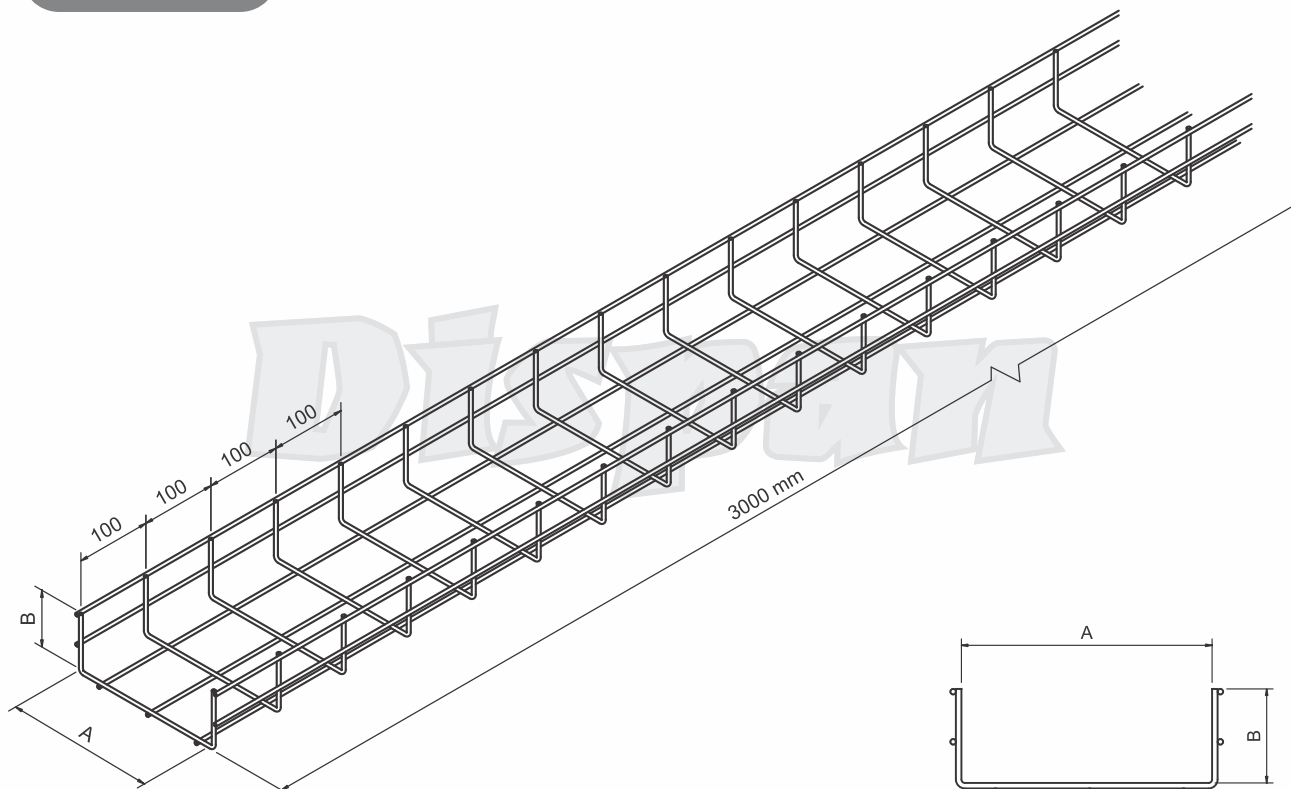

ELETROCALHA ARAMADA LEVE - REF. DP900 / ABA 50 mm					
Largura mm	Aba mm	Distanciamento entre suportes em Milímetros.			
		1500 mm	2000 mm	2500 mm	3000 mm
100	50	38 Kg	36 Kg	34 Kg	32 Kg
150	50	38 Kg	36 Kg	32 Kg	30 Kg
200	50	40 Kg	35 Kg	30 Kg	30 Kg
300	50	40 Kg	35 Kg	30 Kg	30 Kg
400	50	45 Kg	40 Kg	35 Kg	30 Kg
500	50	45 Kg	40 Kg	35 Kg	30 Kg

*Carga Distribuída Entre Suportes.

EXEMPLO:

- ← *OU 14 CABOS 0.6/1KV DE 70,0MM2 NO VÃO LIVRE DE 3.0 METROS
- ← *OU 28 CABOS 0.6/1KV DE 25,0MM2 NO VÃO LIVRE DE 3.0 METROS
- ← *OU 25 CABOS 0.6/1KV DE 35,0MM2 NO VÃO LIVRE DE 3.0 METROS

ELETROCALHA ARAMADA LEVE - REF. DP900 / ABA 75 mm					
Largura mm	Aba mm	Distanciamento entre suportes em Milímetros.			
		1500 mm	2000 mm	2500 mm	3000 mm
100	50	45 Kg	40 Kg	36 Kg	34 Kg
150	50	45 Kg	40 Kg	36 Kg	34 Kg
200	50	55 Kg	45 Kg	40 Kg	38 Kg
300	50	55 Kg	45 Kg	40 Kg	38 Kg
400	50	65 Kg	55 Kg	50 Kg	42 Kg
500	50	65 Kg	55 Kg	50 Kg	42 Kg

*Carga Distribuída Entre Suportes.

EXEMPLO:

- ← *OU 06 CABOS 0.6/1KV DE 185,0MM2 NO VÃO LIVRE DE 3.0 METROS
- ← *OU 16 CABOS 0.6/1KV DE 70,0MM2 NO VÃO LIVRE DE 3.0 METROS
- ← *OU 14 CABOS 0.6/1KV DE 95,0MM2 NO VÃO LIVRE DE 3.0 METROS

ELETROCALHA ARAMADA LEVE - REF. DP900 / ABA 100 mm					
Largura mm	Aba mm	Distanciamento entre suportes em Milímetros.			
		1500 mm	2000 mm	2500 mm	3000 mm
100	100	55 Kg	51 Kg	46 Kg	40 Kg
150	100	55 Kg	51 Kg	46 Kg	40 Kg
200	100	65 Kg	55 Kg	50 Kg	45 Kg
300	100	70 Kg	60 Kg	55 Kg	48 Kg
400	100	100 Kg	85 Kg	65 Kg	50 Kg
500	100	100 Kg	85 Kg	65 Kg	50 Kg

*Carga Distribuída Entre Suportes.

EXEMPLO:

- ← *OU 13 CABOS 0.6/1KV DE 95,0MM2 NO VÃO LIVRE DE 3.0 METROS
- ← *OU 20 CABOS 0.6/1KV DE 70,0MM2 NO VÃO LIVRE DE 3.0 METROS
- ← *OU 30 CABOS 0.6/1KV DE 50,0MM2 NO VÃO LIVRE DE 3.0 METROS

Nota.: Para outras medidas, favor solicitar.

Leito Sanitário / Eletrocalha Aramada 1/4" Tipo Leve

Wire mesh cable tray 1/4" lightweight kind

DP 900

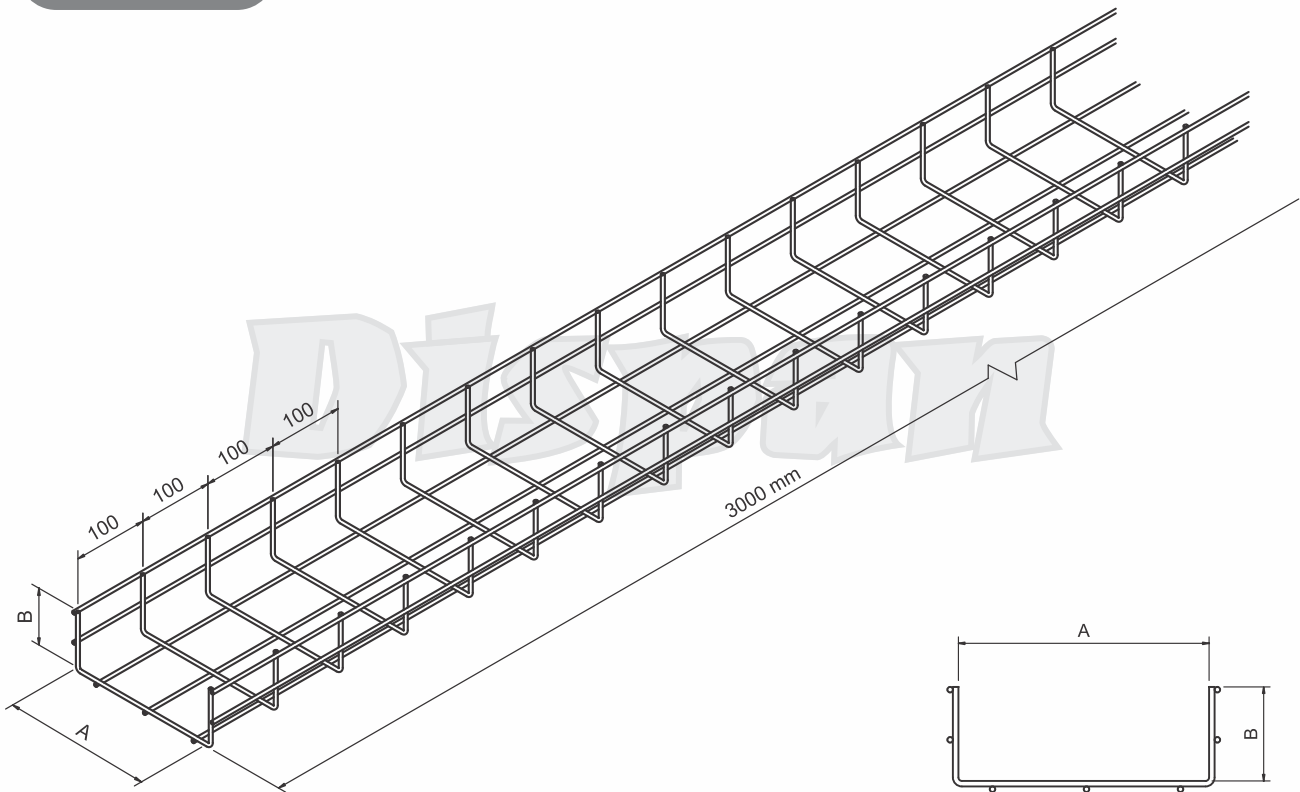

ELETROCALHA ARAMADA PESADA - REF. DP900 / ABA 50 mm					
Largura mm	Aba mm	Distanciamento entre suportes em Milímetros.			
		1500 mm	2000 mm	2500 mm	3000 mm
100	50	50 Kg	47 Kg	44 Kg	40 Kg
150	50	50 Kg	47 Kg	44 Kg	40 Kg
200	50	60 Kg	50 Kg	45 Kg	40 Kg
300	50	65 Kg	55 Kg	50 Kg	40 Kg
400	50	70 Kg	60 Kg	50 Kg	40 Kg
500	50	70 Kg	60 Kg	50 Kg	40 Kg

*Carga Distribuída Entre Suportes.

EXEMPLO:

- ← *OU 33 CABOS 0.6/1KV DE 35,0MM² NO VÃO LIVRE DE 3.0 METROS
- ← *OU 11 CABOS 0.6/1KV DE 120,0MM² NO VÃO LIVRE DE 3.0 METROS
- ← *OU 25 CABOS 0.6/1KV DE 50,0MM² NO VÃO LIVRE DE 3.0 METROS

ELETROCALHA ARAMADA PESADA - REF. DP900 / ABA 75 mm					
Largura mm	Aba mm	Distanciamento entre suportes em Milímetros.			
		1500 mm	2000 mm	2500 mm	3000 mm
100	50	60 Kg	55 Kg	46 Kg	43 Kg
150	50	60 Kg	55 Kg	46 Kg	43 Kg
200	50	70 Kg	60 Kg	55 Kg	50 Kg
300	50	70 Kg	60 Kg	55 Kg	50 Kg
400	50	90 Kg	80 Kg	70 Kg	55 Kg
500	50	90 Kg	80 Kg	70 Kg	55 Kg

*Carga Distribuída Entre Suportes.

EXEMPLO:

- ← *OU 05 CABOS 0.6/1KV DE 240,0MM² NO VÃO LIVRE DE 3.0 METROS
- ← *OU 10 CABOS 0.6/1KV DE 150,0MM² NO VÃO LIVRE DE 3.0 METROS
- ← *OU 32 CABOS 0.6/1KV DE 50,0MM² NO VÃO LIVRE DE 3.0 METROS

ELETROCALHA ARAMADA PESADA - REF. DP900 / ABA 100 mm					
Largura mm	Aba mm	Distanciamento entre suportes em Milímetros.			
		1500 mm	2000 mm	2500 mm	3000 mm
100	100	65 Kg	60 Kg	50 Kg	47 Kg
150	100	65 Kg	60 Kg	50 Kg	47 Kg
200	100	85 Kg	80 Kg	75 Kg	70 Kg
300	100	95 Kg	85 Kg	80 Kg	70 Kg
400	100	140 Kg	110 Kg	85 Kg	70 Kg
500	100	140 Kg	110 Kg	85 Kg	70 Kg

*Carga Distribuída Entre Suportes.

EXEMPLO:

- ← *OU 13 CABOS 0.6/1KV DE 120,0MM² NO VÃO LIVRE DE 3.0 METROS
- ← *OU 09 CABOS 0.6/1KV DE 240,0MM² NO VÃO LIVRE DE 3.0 METROS
- ← *OU 12 CABOS 0.6/1KV DE 185,0MM² NO VÃO LIVRE DE 3.0 METROS

Nota.: Para outras medidas, favor solicitar.

Como solicitar conexões para eletrocalha aramada.

How to specify connections for wire mesh cable tray.

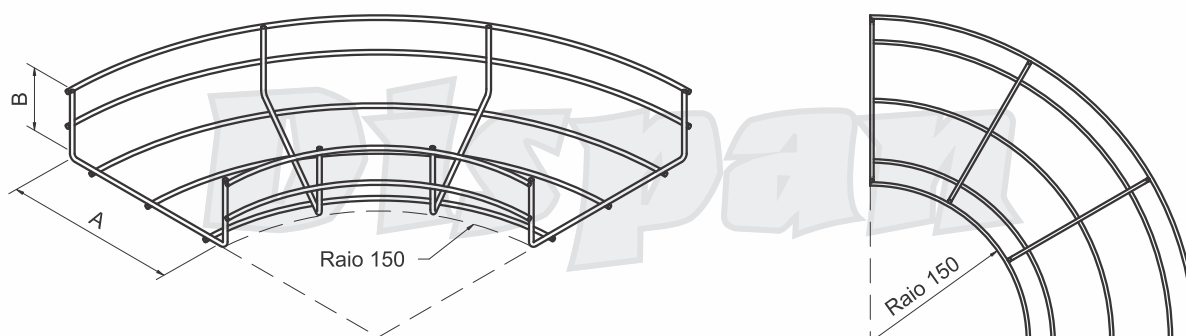

Exemplo:

Example

DP901 900 - AC - GF - 400/100 - 3/16"

Referência do catálogo de produtos com características básicas.

Modelo da eletrocalha aramada.

Matéria-prima de fabricação.

Acabamento.

Largura / altura da eletrocalha.

Bitola do arame de construção da eletrocalha aramada.

DP901 - Curva horizontal 90°

Matéria-prima base

AC - Aço carbono
AI - Aço inox

Acabamento aplicado na matéria-prima em base de aço carbono.

GF - Galvanizado à fogo por imersão
GE - Galvanizado eletrolítico
PT - Galvanizado e Pintado

Largura

400 - Largura da eletrocalha desejada (De 30mm a 1000mm)

Altura

100 - Altura da eletrocalha desejada (30mm / 50mm / 75mm / 100mm / 150mm)

Diâmetro da bitola dos arames.

3/16" - Bitola da eletrocalha aramada = Tipo Leve.
1/4" - Bitola da eletrocalha aramada = Tipo Pesado.

Descritivo técnico.

DP901 - Curva horizontal 90° para eletrocalha aramada DP 900, em aço carbono, galvanizado fogo, largura de 400 mm, com aba de 100 mm na bitola 3/16", raio de 300 mm, curvilínea.

Montagem com conector curto ou reforçado.

50 à 75 mm = 2 Conectores.

Larguras: 100 à 200 mm = 3 Conectores.

300 à 1000 mm = 4 Conectores.

*Para solicitação da tampa, colocar o código + a letra "T": Exemplo = DP901T

Nota - 1

Ocasionalmente podem ocorrer algumas distorções de medidas em nossas peças, por diversos fatores. Por este motivo damos uma tolerância de 5,0 mm entre as medidas mencionadas no catálogo e as peças reais. As peças de conexões entre as partes contêm furos oblongos para corrigir eventuais diferenças.

Curva Horizontal 90° - DP901

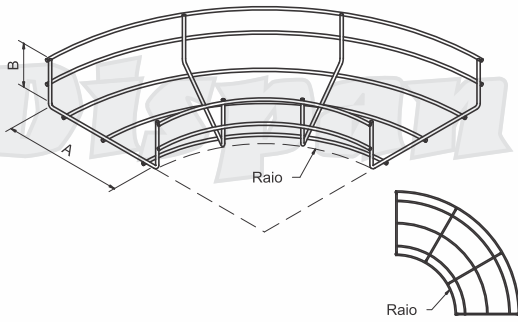

Indicar cota A e B.

Curva Horizontal 45° - DP902

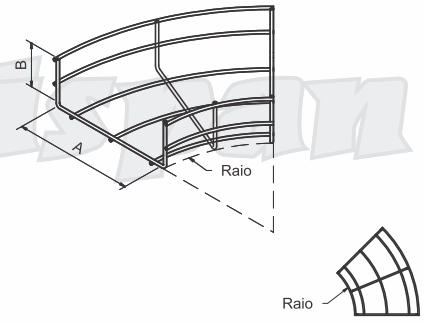

Indicar cota A e B.

Curva Vertical Externa 90° - DP903

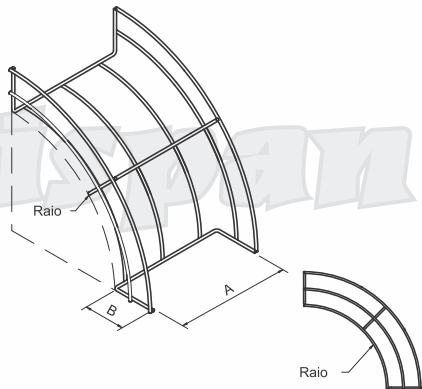

Indicar cota A e B.

Curva Vertical Externa 45° - DP904

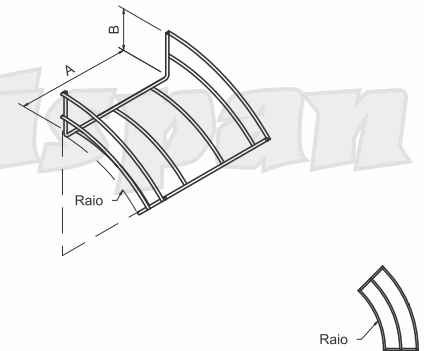

Indicar cota A e B.

Curva Vertical Interna 90° - DP905

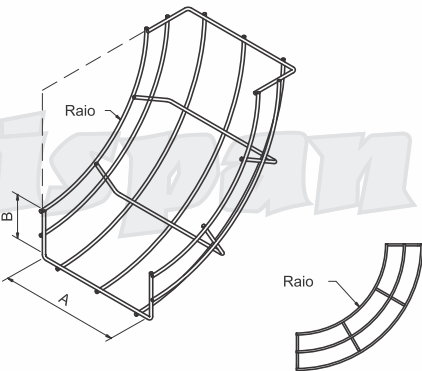

Indicar cota A e B.

Curva Vertical Interna 45° - DP906

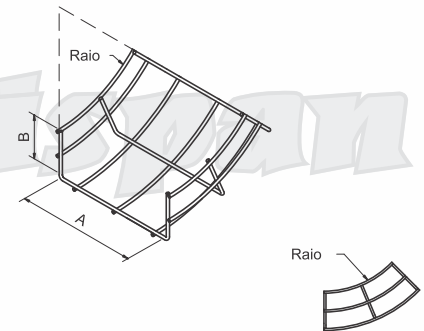

Indicar cota A e B.

Tê Horizontal 90° - DP907

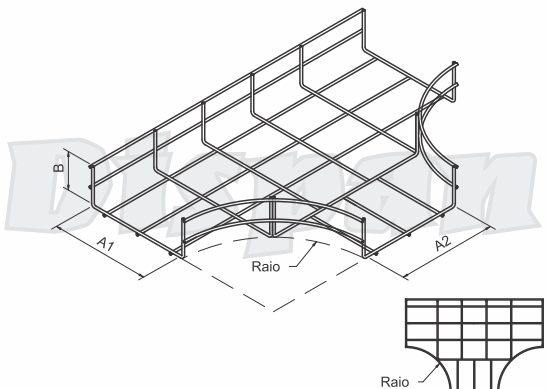

Indicar cota A e B.

Cruzeta Horizontal 90° - DP908

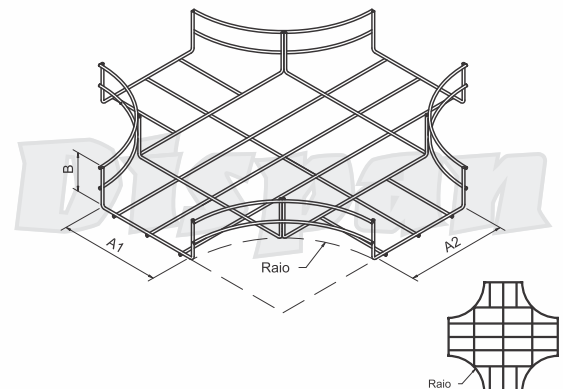

Indicar cota A e B.

Redução Concêntrica - DP909

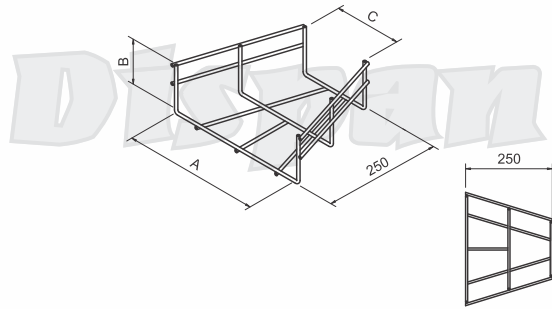

Indicar cota A e B.

Redução Esquerda - DP910

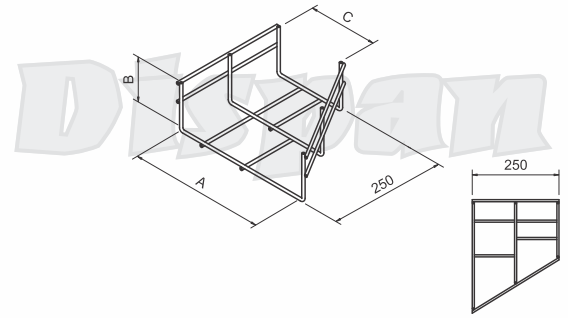

Indicar cota A e B.

Redução Direita - DP911

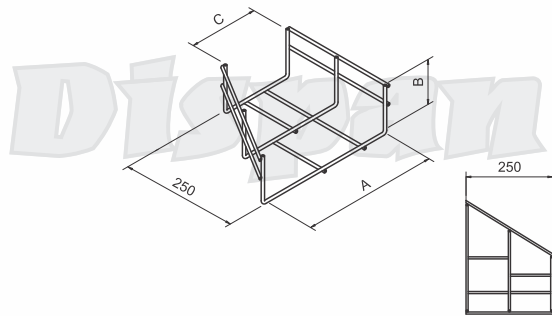

Indicar cota A e B.

Conector Curto - DP912

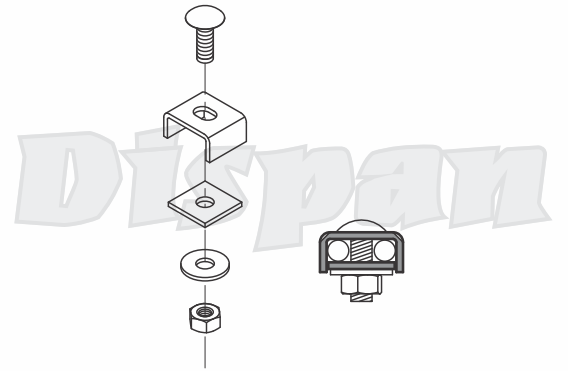

Obs.: Incluso parafuso, porca e arruela.

Conector Curto Reforçado - DP913

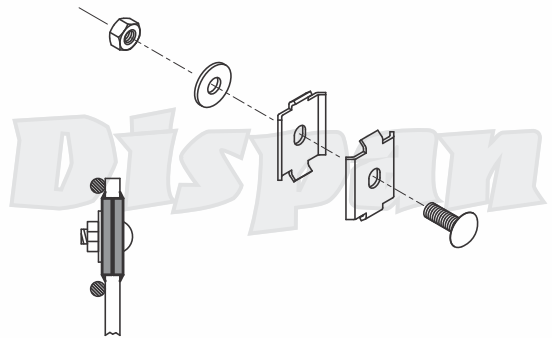

Obs.: Incluso parafuso, porca e arruela.

Conector Longo - DP914

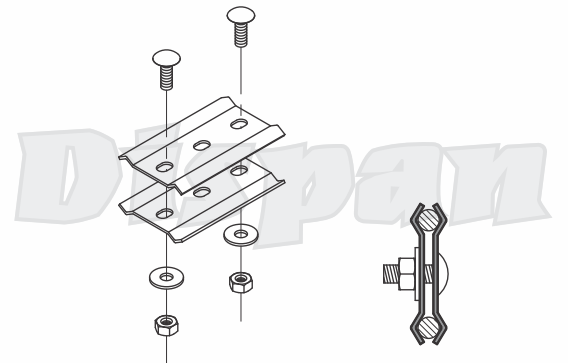

Obs.: Incluso parafuso, porca e arruela.

Junção Articulada P/ Eletrocalha Aramada - DP915

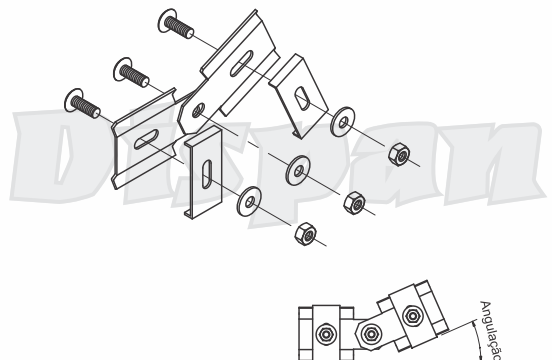

Obs.: Incluso parafuso, porca e arruela.

União Curta - DP916

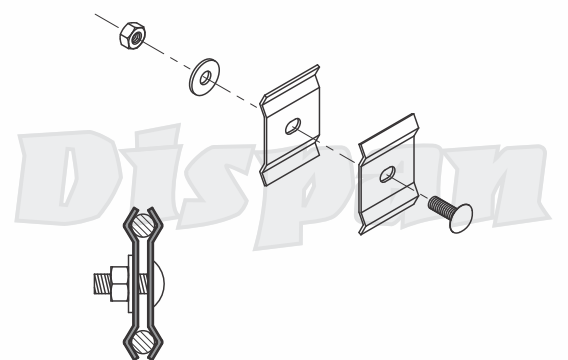

Obs.: Incluso parafuso, porca e arruela.

Presilha Para Base - DP917

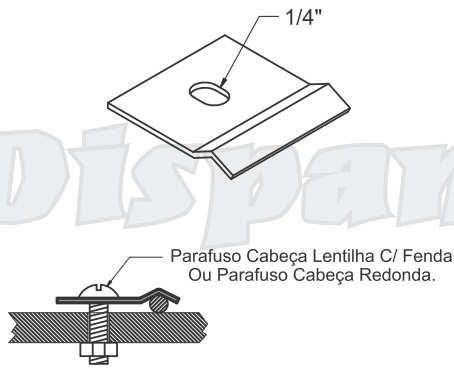

Obs.: Não inclui parafuso.

Conector Longo de Pressão - DP918

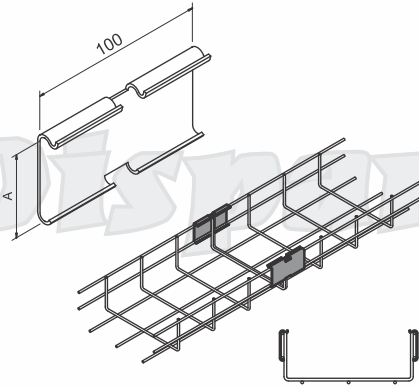

Indicar cota A.

Conector Trecho Reto Reforçado - DP919

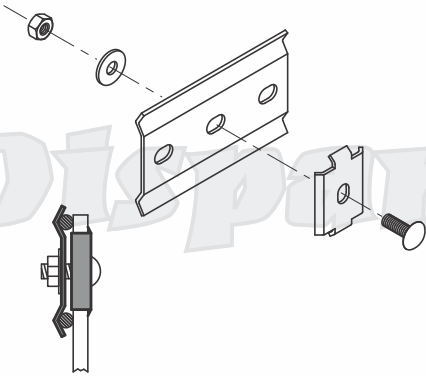

Obs.: Incluso parafuso, porca e arruela.

Presilha Para Tampa de Encaixe Para Aramado - DP920

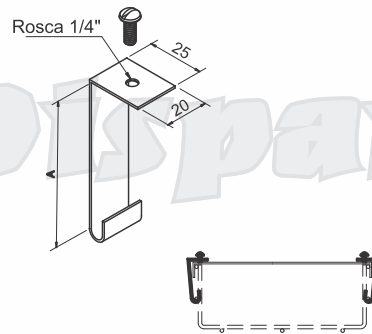

Obs.: Incluso parafuso, porca e arruela.

Flange P/ Ligação em Painel - DP921

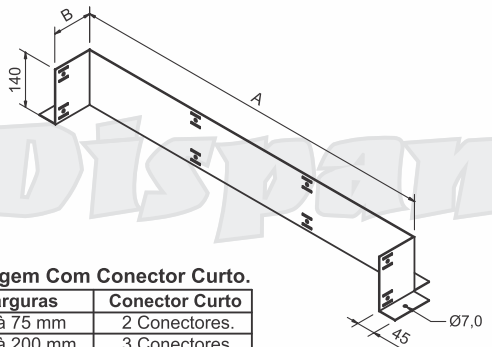

Montagem Com Conector Curto.

Larguras	Conector Curto
50 à 75 mm	2 Conectores.
100 à 200 mm	3 Conectores.
300 à 1000 mm	4 Conectores.

Curva de Inversão 90° - DP922

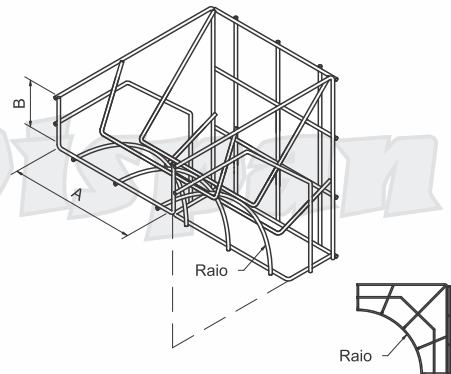

Indicar cota A e B.

Curva Com Passagem Reto de Subida 90° - DP923

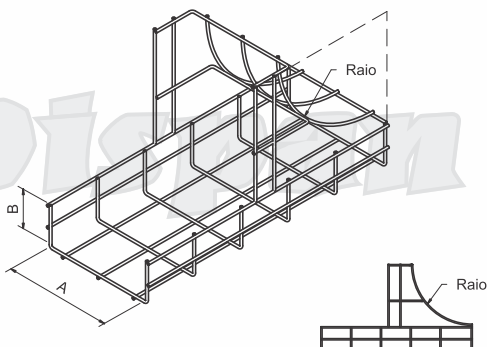

Indicar cota A e B.

Cotovelo Reto 90° - DP924

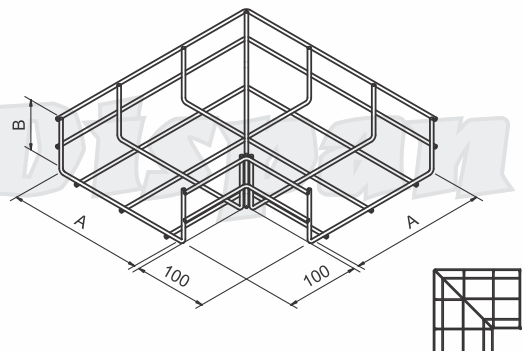

Indicar cota A e B.

Tê Reto 90° - DP925

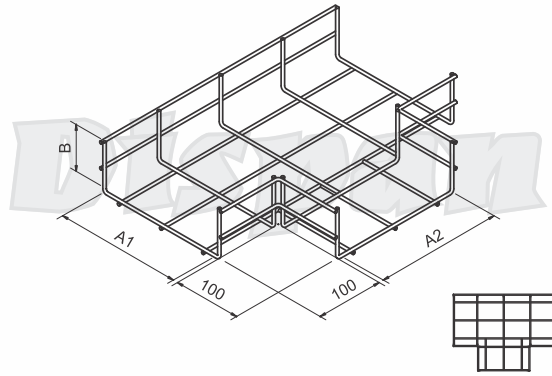

Indicar cota A e B.

Cruzeta Reta 90° - DP926

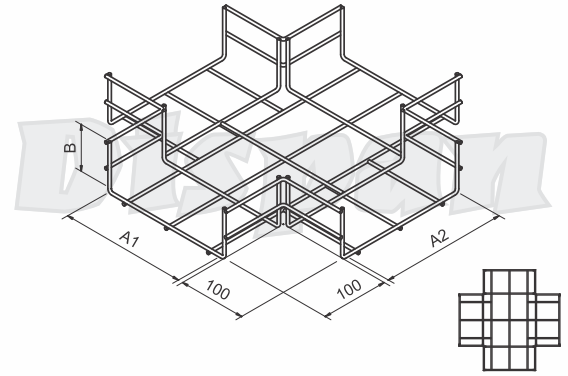

Indicar cota A e B.

Tê Vertical de Descida 90° - DP927

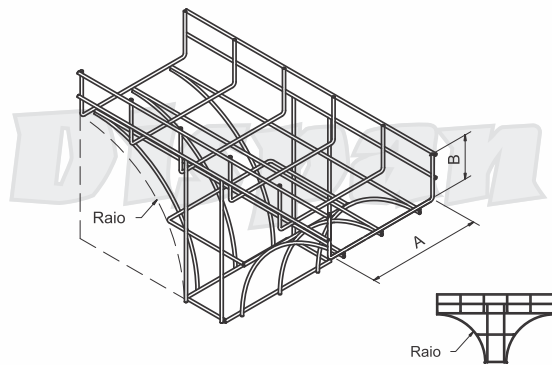

Indicar cota A e B.

Tê Vertical de Subida 90° - DP928

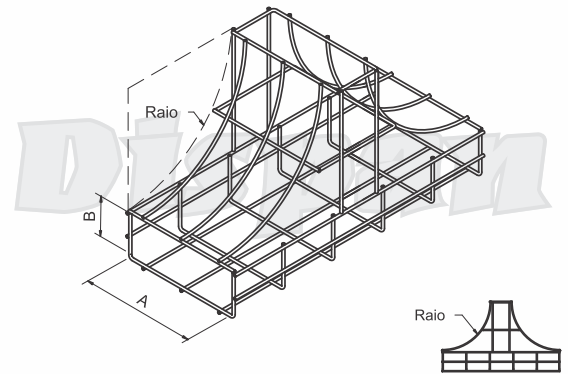

Indicar cota A e B.

Tê Vertical de Descida Lateral - DP929

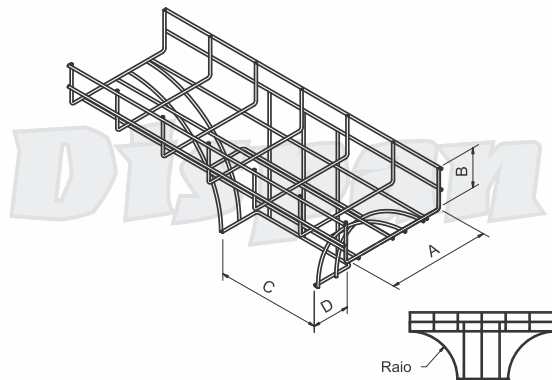

Indicar cota A e B.

Tampa de Encaixe P/ Aramado - DP930

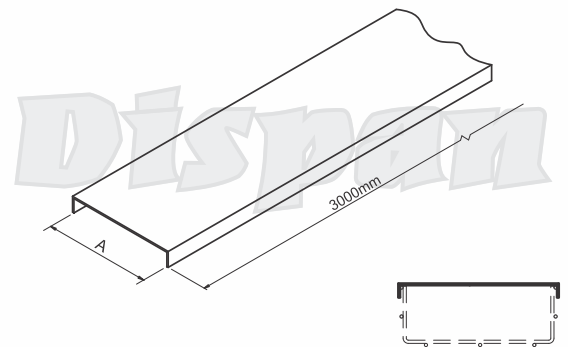

Obs.: Informar a bitola do arame.

Tampa de Pressão P/ Eletrocalha Aramada - DP931

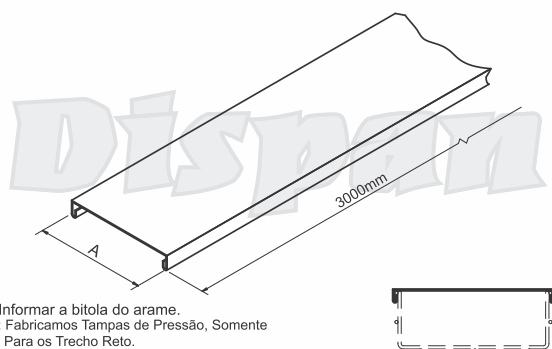

Obs.: Informar a bitola do arame.
Nota 1: Fabricamos Tampas de Pressão, Somente Para os Trecho Reto.

Nota 2: Tampas de Pressão, Somente Para Eletrocalha Aramada Com Altura Superior à 50 mm.

Conector para Emenda - DP912

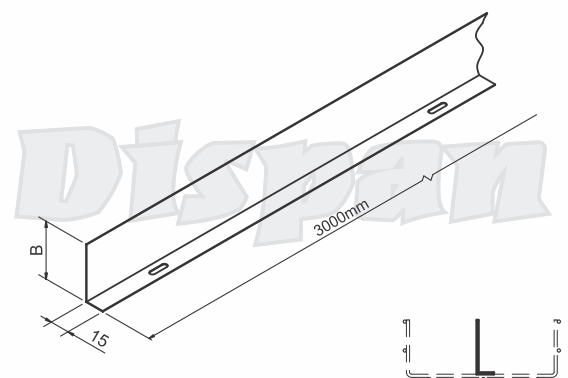

Septo Divisor Perfurado - DP933

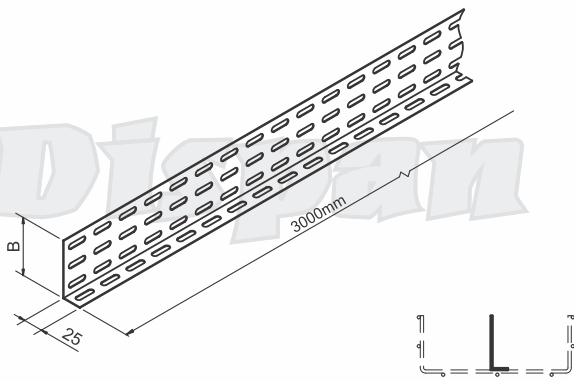

Suporte P/ Caixa de Tomada em Eletrocalha Aramada - DP934

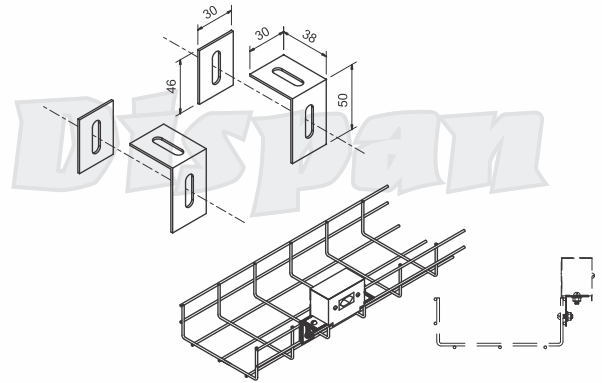

Suporte Horizontal P/ Eletrocalha Aramada - DP935

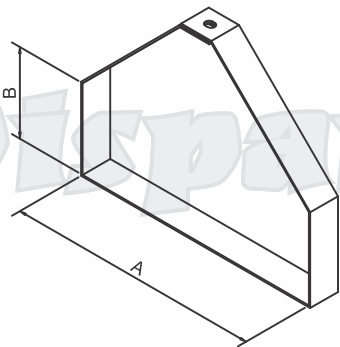

Obs.: De acordo com as dimensões das eletrocalhas.

Suporte Vertical P/ Eletrocalha Aramada - DP936

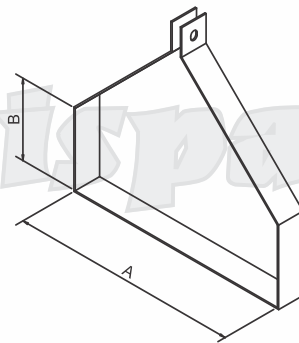

Obs.: De acordo com as dimensões das eletrocalhas.

Suporte Duplo P/ Eletrocalha Aramada - DP937

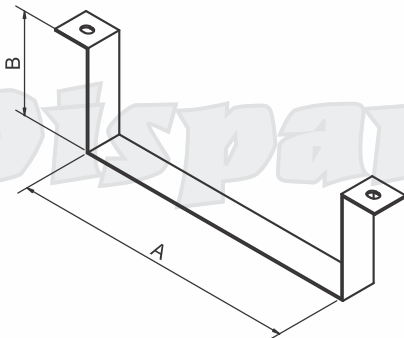

Obs.: De acordo com as dimensões das eletrocalhas.

Suporte Reforçado P/ Eletrocalha Aramada - DP938

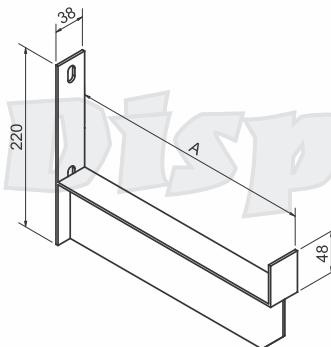

Referência: DP 938	
Suporte reforçado.	
Tabela de cargas.	
A mm	Carga Máxima Kg.
50	120
100	80
150	70
200	50
300	20
400	15

Largura máxima de "A" = 400mm.

Tala Para Saída Horizontal em Eletrocalha Aramada - DP939

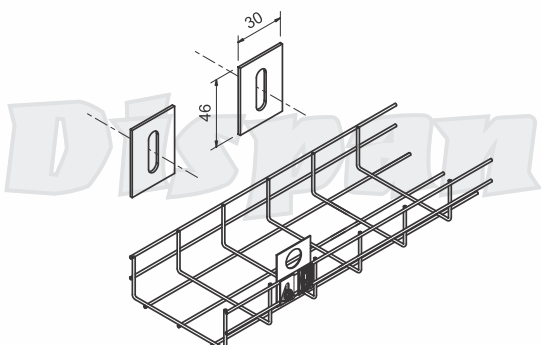

Saída Horizontal Para Eletroduto - DP751

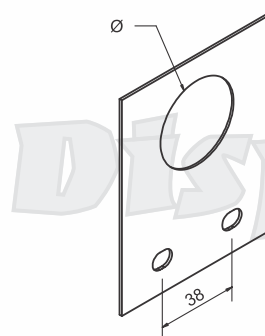

Referência	Ø
751 - 1	1/2"
751 - 2	3/4"
751 - 3	1"
751 - 4	1.1/4"
751 - 5	1.1/2"
751 - 6	2"
751 - 7	3"
751 - 8	3.1/2"
751 - 9	4"

Obs.: Indicar o Ø.

Exemplo de montagem para eletrocalha aramada

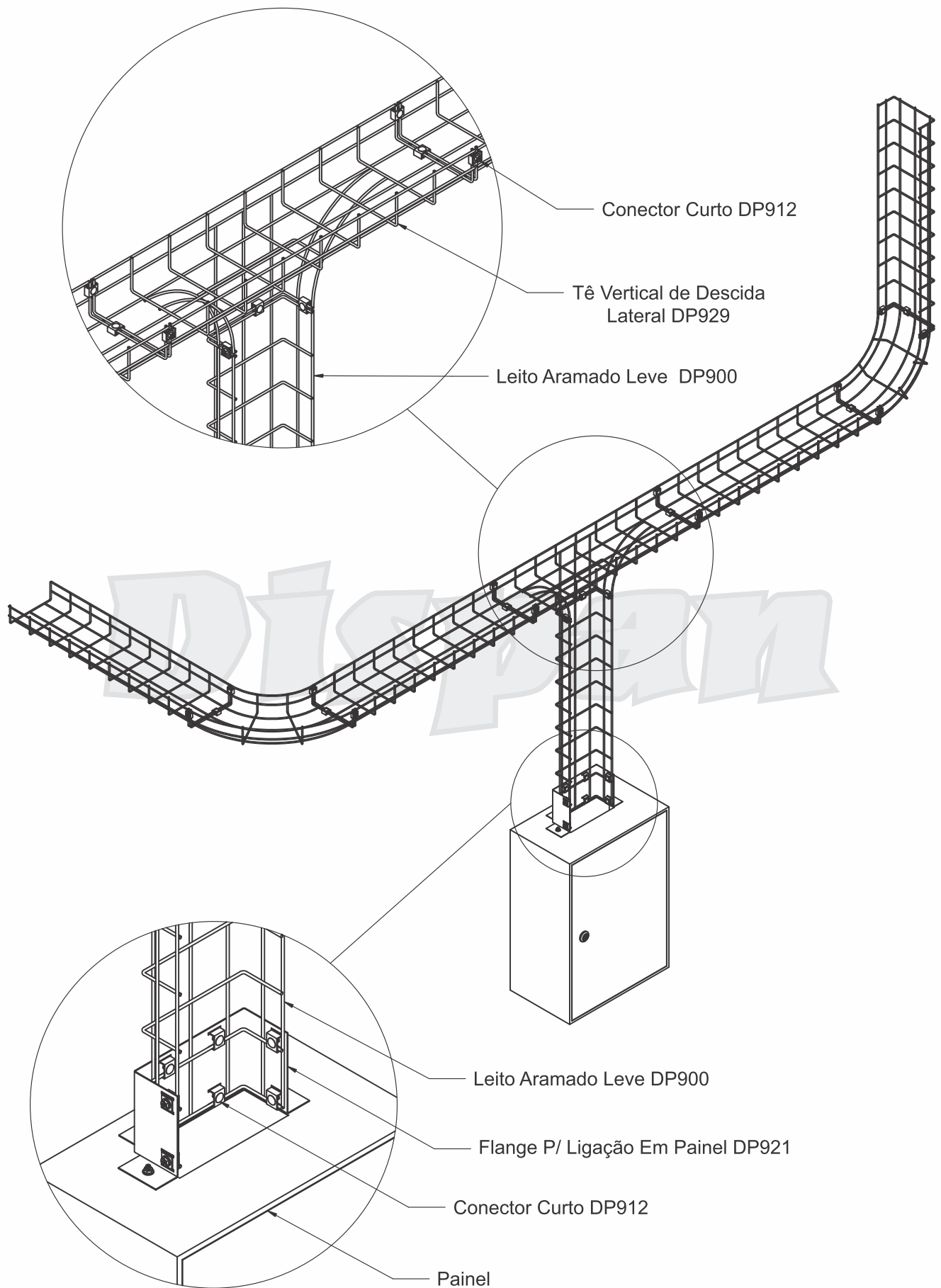

Exemplo de montagem para eletrocalha aramada

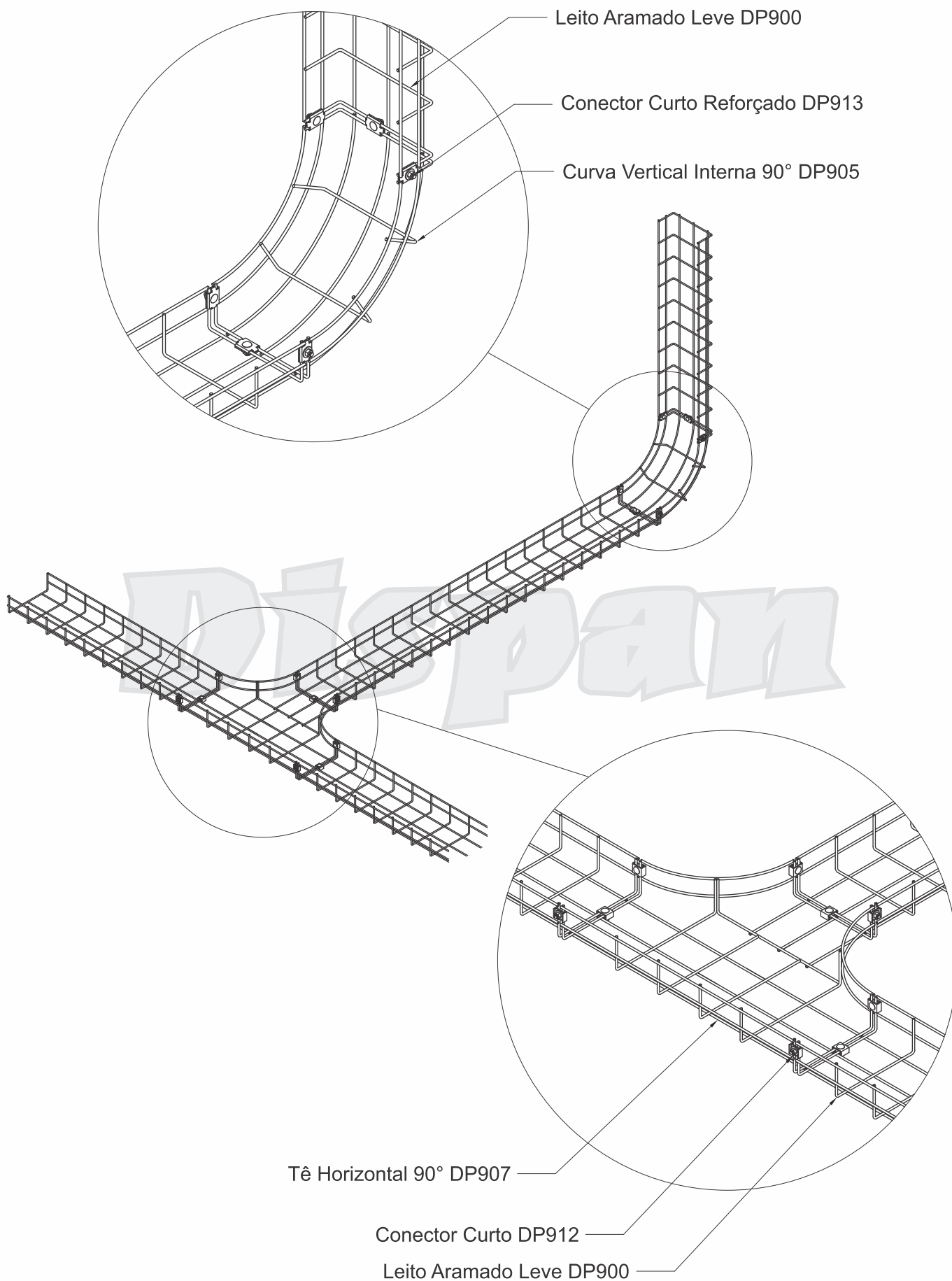

Exemplo de montagem para eletrocalha aramada

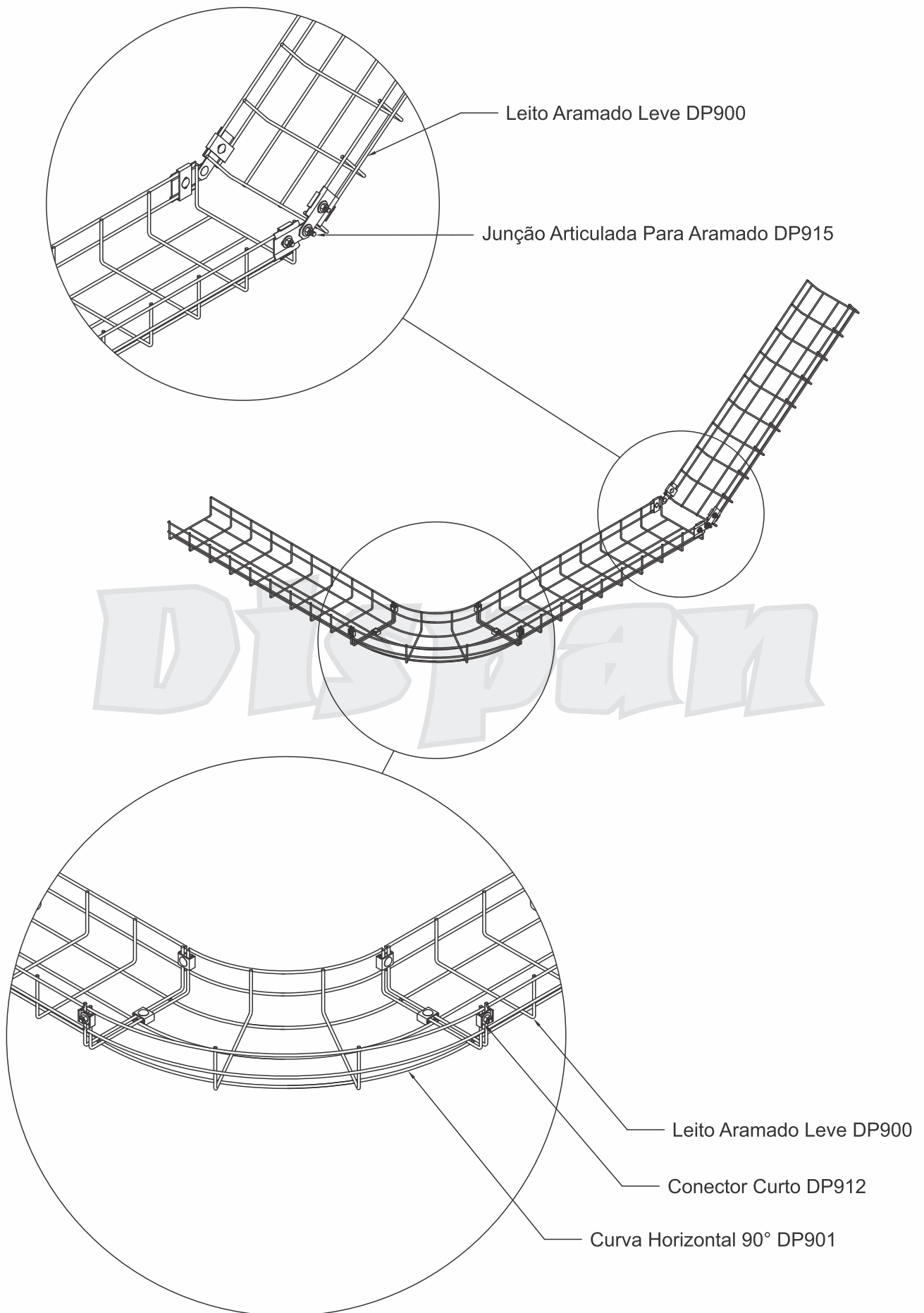

Exemplo de montagem para eletrocalha aramada

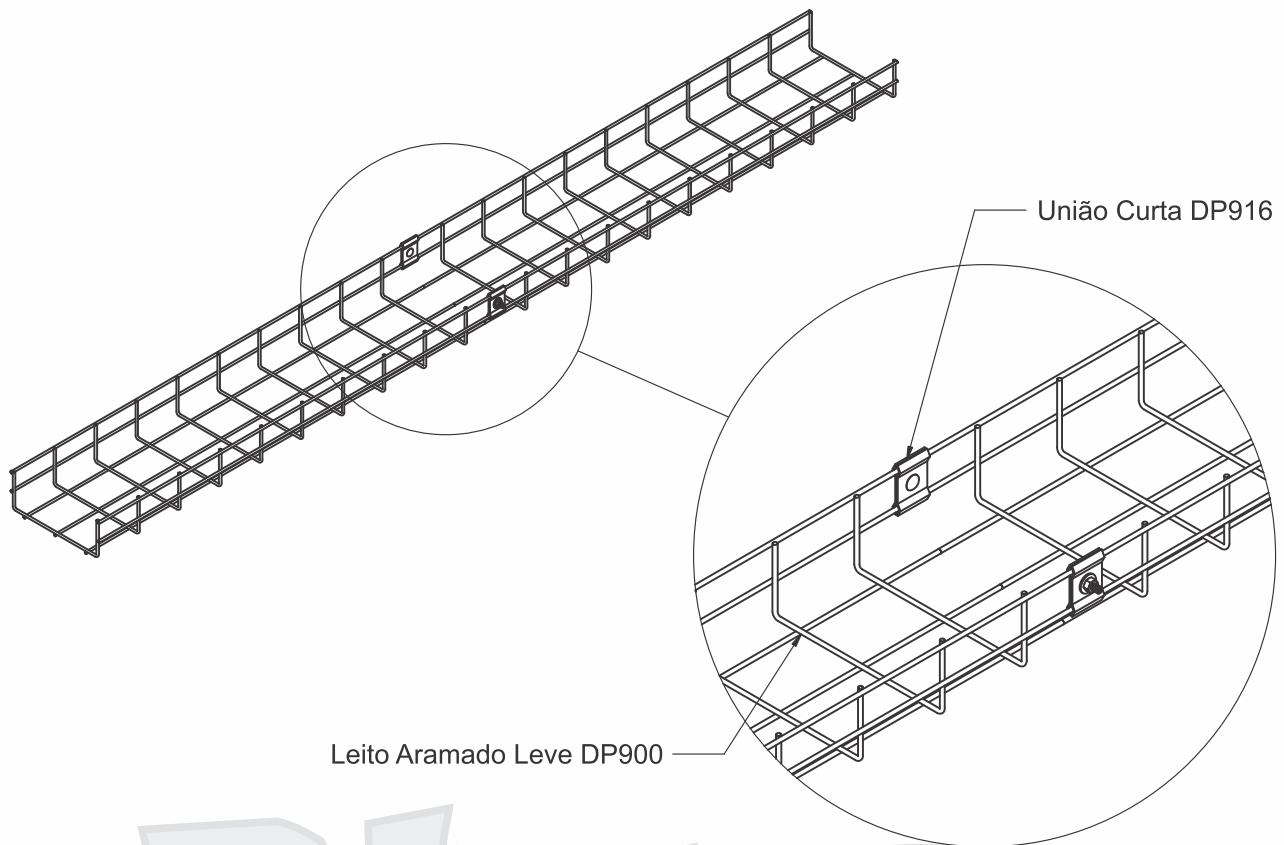

Dispan

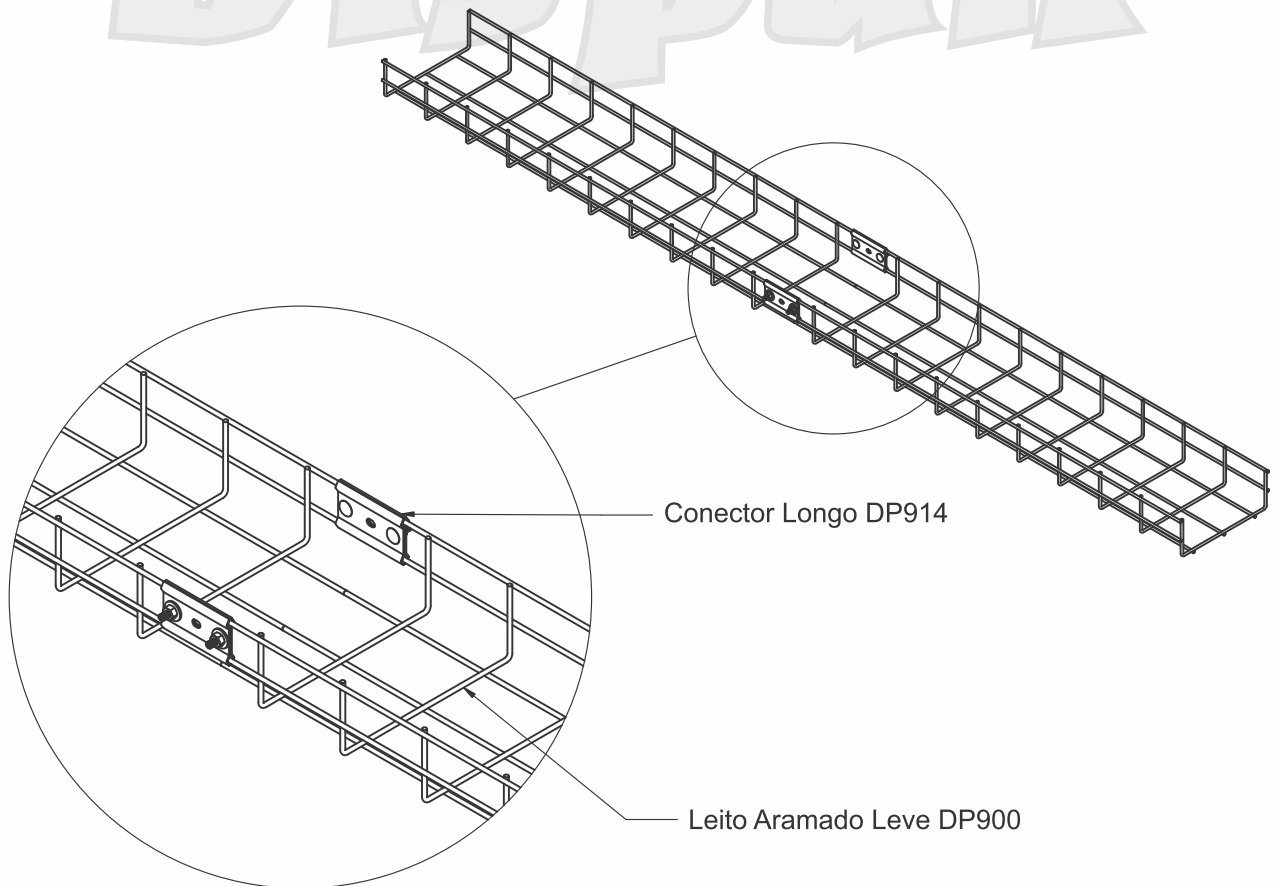



Dispan

Rua José Francisco da Silva, 133/144 • Fritz Berzin
Nova Odessa / SP • Brasil • CEP 13380-248
+55 (19) 3466.9300 • comercial@dispan.com.br

www.dispan.com.br